

- Notes**
- PCB or Heat Sink level
 - Led location
- Ensure LED fitting, see our web site and/or 3D model for part detail.

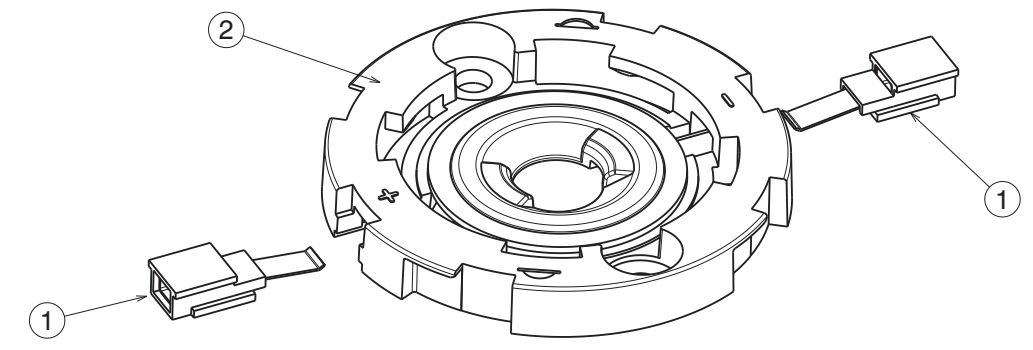

Code table

HEKLA CONNECTOR	COB SIZE [mm]	LES MAX. [mm]	HEKLA-SOCKET
FP15490_HEKLA-A	12,5X12,5	φ9,0	F15253_HEKLA-SOCKET-A
FP15500_HEKLA-B	17,85X17,85	φ14,2	F15254_HEKLA-SOCKET-B
FP15501_HEKLA-C	13,5X13,5	φ11,6	F15255_HEKLA-SOCKET-C
FP15502_HEKLA-D	15,85X15,85	φ10,7	F15256_HEKLA-SOCKET-D
FP15503_HEKLA-E	15,8X15,8	φ14,3	F14988_HEKLA-SOCKET-E
FP15947_HEKLA-G	12X15	φ10	F15848_HEKLA-SOCKET-G
FP15948_HEKLA-H	16X19	φ14	F15858_HEKLA-SOCKET-H
FP15949_HEKLA-I	19X19	φ17	F15859_HEKLA-SOCKET-I
FP15957_HEKLA-J	13,35X13,35	φ7,5	F15956_HEKLA-SOCKET-J
			F15616_HEKLA-SOCKET-F

COMPONENTS

INDEX	PRODUCT	TYPE	MATERIAL	COLOUR/COATING
1	FPXXXXX_HEKLA-PIC-X	CONTACT SPRING ASSEMBLY	PBT+BeCu	White+gold
2	See code table	SOCKET	PBT	White
3	See code table	CONNECTOR	PBT+BeCu	White+gold

MECHANICAL DRAWING

PRODUCT
HEKLA-family



Tolerances if not otherwise shown
According to DIN ISO 2768-1
Linear measures:
Up to 30mm class M, otherwise class C.
According to DIN ISO 2768-2
Form and position: class L

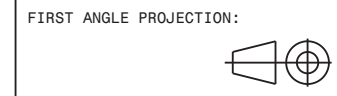

This drawing is the property of LEDiL Oy. It may not be reproduced, copied or communicated without a written agreement with LEDiL Oy.

SCALE	2:1	SIZE	A3	SHEET	1/2
-------	-----	------	----	-------	-----

GENERAL INFORMATION	
RATED VOLTAGE/CURRENT	50VDC/3A FOR USE IN SELV AND CLASS 2 (USA) APPLICATIONS ONLY
WIRE TYPE AND SIZE	SOLID WIRE 22 AWG (Φ0,64mm); TINNED WIRE 22-20 AWG(SOLDER DIPPED)
WIRE STRIP LENGTH	5 +/- 0,5 mm
FASTENING	SCREWS 2XM3, WASHER 2XM3
MAX.SCREW FIXING TORQUE	0,6Nm
MAX.TIM THICKNESS	0,25mm
RATED TEMPERATURE	110°C

GENERAL ASSEMBLY INSTRUCTION

Solid wire AWG 22
Tinned wire AWG 22-20(solder dipped)
Strip length 5mm

Screws M3+Washers
(DIN125/DIN127)
Max.torque 0,6Nm

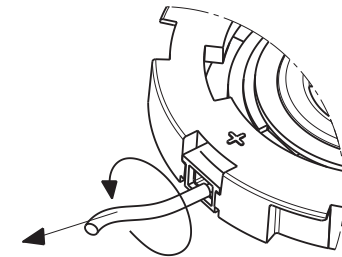

Remove the wire by slightly pulling and rotating at the same time. A new wire is recommended after removing the old one and check the functionality of the connector.

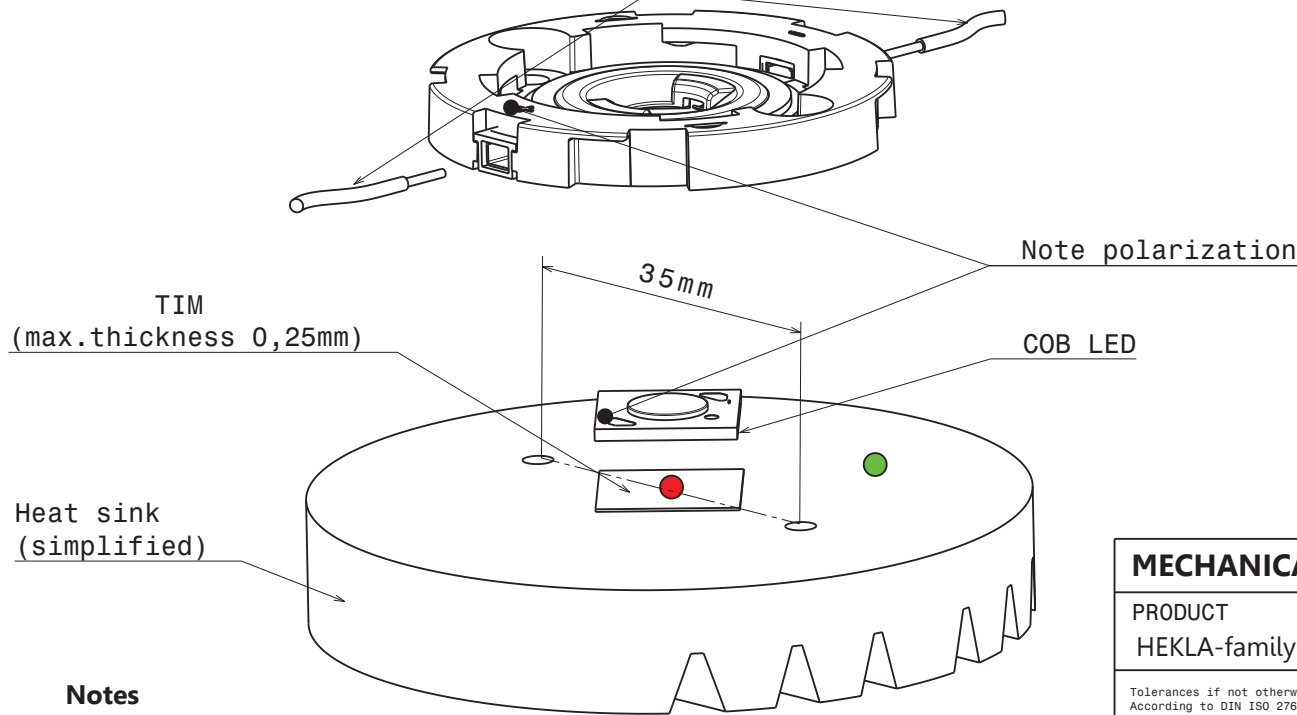

After wire installation, we recommend using a strain relief mechanism during the luminaire assembly to avoid any stress on the wires which may result in a loose connection.

Contact springs must not be subject to any excess force from the wires after the final assembly.

Notes

- PCB or Heat Sink level
- Led location
- Ensure LED fitting, see our web site and/or 3D model for part detail.

MECHANICAL DRAWING		LEDiL[®]
PRODUCT HEKLA-family		
<small>Tolerances if not otherwise shown According to DIN ISO 2768-1 Linear measures: Up to 30mm class M, otherwise class C. According to DIN ISO 2768-2 Form and position: class L</small>	FIRST ANGLE PROJECTION: 	This drawing is the property of LEDiL Oy. It may not be reproduced, copied or communicated without a written agreement with LEDiL Oy.
SCALE 2:1	SIZE A3	SHEET 2/2