

Customer Information Sheet

DRAWING No.: M90-602XX45

SHEET 2 OF 2

IF IN DOUBT - ASK

©

NOT TO SCALE

THIRD ANGLE PROJECTION

ALL DIMENSIONS IN mm

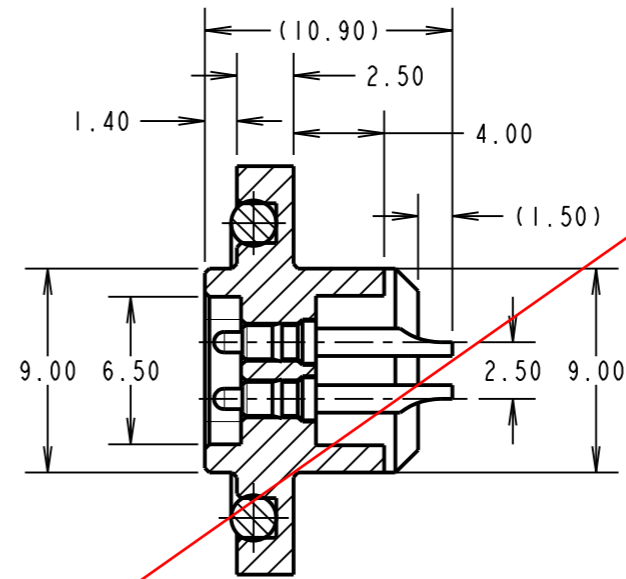
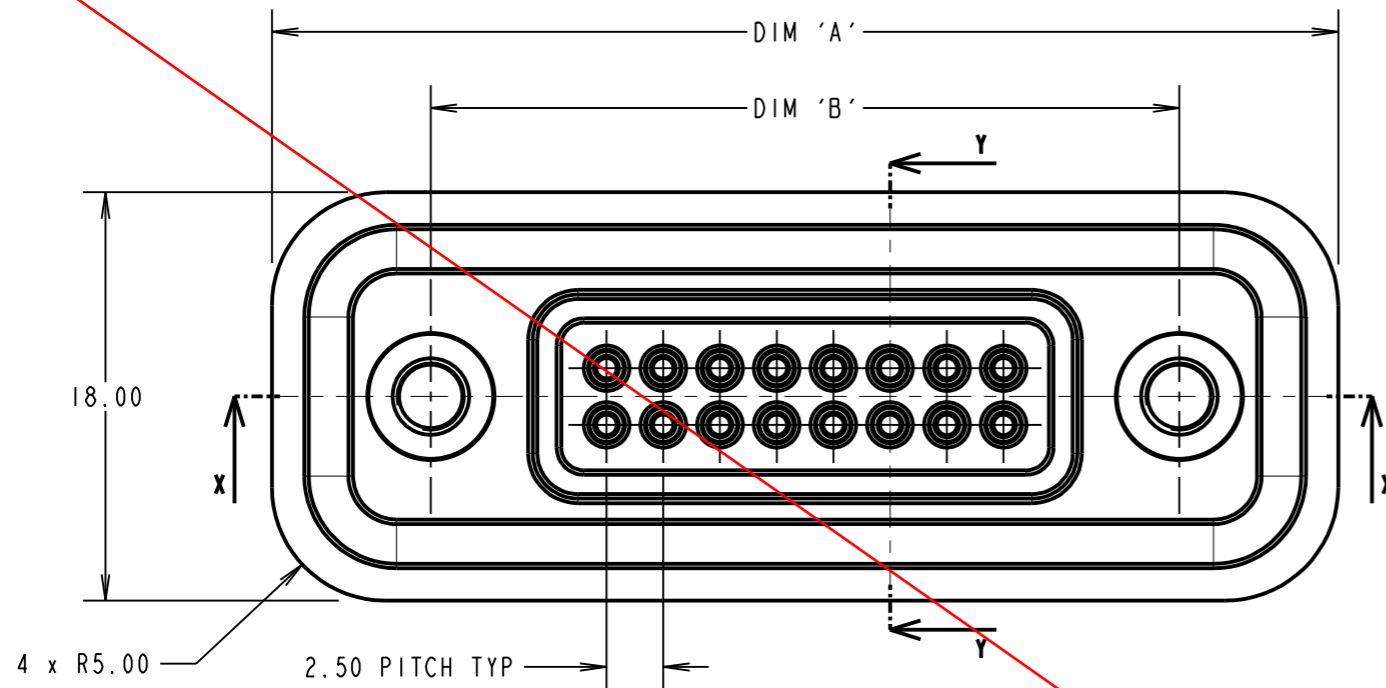

SECTION Y-Y

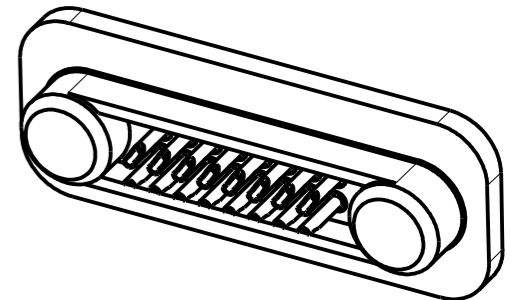
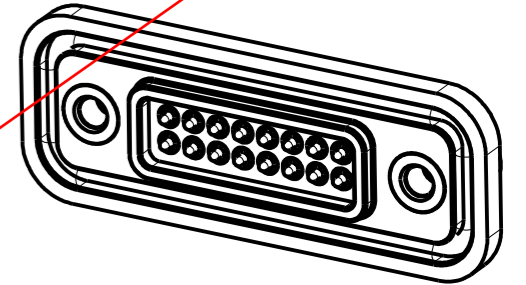

OBSOLETE

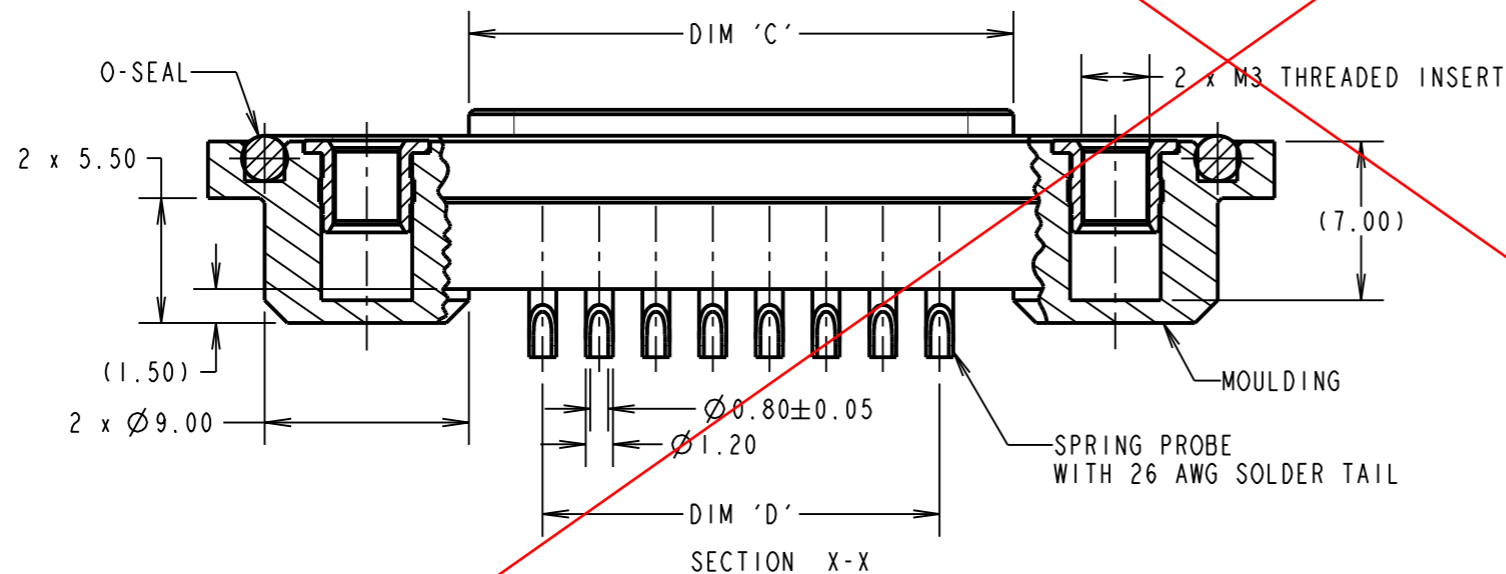

SECTION X-X

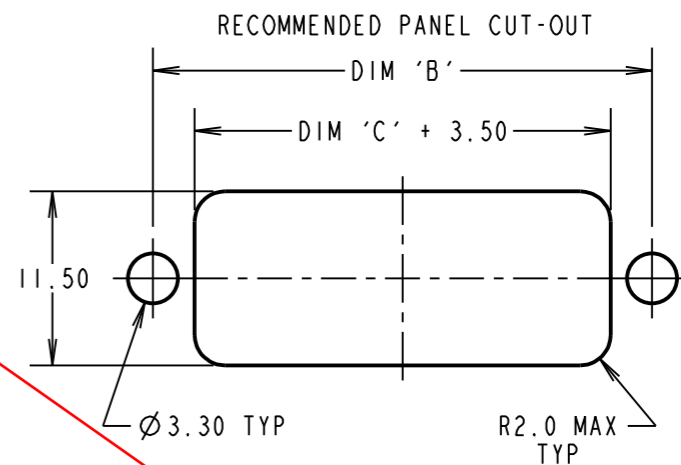

SPECIFICATION:

MATERIAL:
 O-SEAL: THERMOPLASTIC ELASTOMER, 35 SHORE A
 MOULDING: 30% GLASS FILLED POLYAMIDE 46, UL94V-0, BLACK
 SPRING PROBE BODY + PISTON: BRASS
 SPRING: STEEL
 THREADED INSERT: BRASS
FINISH:
 SPRING PROBE:
 BODY + PISTON = GOLD OVER NICKEL
 SPRING = ZINC
ELECTRICAL:
 CONTACT RATING: 1A
 WORKING VOLTAGE: 240V DC
 CONTACT RESISTANCE: 50 MILLIOHMS
 INSULATION RESISTANCE: 1000 MEGOHMS MIN AT 500V DC
ENVIRONMENTAL:
 OPERATING TEMPERATURE: -40°C TO +100°C

NOTES:

- DRAWING SHOWS 16-WAY CONNECTOR.
- RECOMMENDED BULKHEAD MOUNTING THICKNESS: 1.50mm.
- RECOMMENDED MOUNTING SCREWS: M3x6 CSK.
- SUITABLE FOR 26 AWG CABLE
- MAXIMUM TORQUE FOR M3 x 6mm CSK MOUNTING SCREWS = 80cNM
 WHEN CONNECTOR IS MOUNTED TO PANEL WITH DIAMETER 3.3 MAX FIXING HOLES.
- WHEN FULLY MATED WITH FIXED CONNECTOR, MOUNTING FLANGES WILL HAVE A GAP OF 3.5mm ±0.1mm TO ALLOW FOR PANEL THICKNESS.

PART No.	No. OF WAYS	DIMENSION			
		A	B	C	D
M90-6020845	8 WAY	37.0	23.00	14.00	7.50
M90-6021245	12 WAY	42.0	28.00	19.00	12.50
M90-6021645	16 WAY	47.0	33.00	24.00	17.50

MSP	7	21.04.15	12843
NAME	ISS.	DATE	C/NOTE
APPROVED:		M.PERREN	
CHECKED:		M.G.PLESTED	
DRAWN:		S.FLOWER	
CUSTOMER REF.:			
ASSEMBLY DRG:			

HARWIN

www.harwin.com
 technical@harwin.com

THIS DRAWING AND ANY INFORMATION OR DESCRIPTIVE MATTER SET OUT HEREON ARE CONFIDENTIAL AND COPYRIGHT PROPERTY OF THE HARWIN GROUP AND MUST NOT BE DISCLOSED, LOANED, COPIED OR USED FOR MANUFACTURING, TENDERING OR FOR ANY OTHER PURPOSE WITHOUT THEIR WRITTEN PERMISSION.

TOLERANCES
 X. = ±1mm
 X.X = ±0.50mm
 X.XX = ±0.10mm
 X.XXX = ±0.01mm
 ANGLES = ±5°
 UNLESS STATED

MATERIAL:
 SEE SPECIFICATION
FINISH:
 S/AREA: mm²

TITLE:
 SPRING PROBE ASSEMBLY WITH 26 AWG SOLDER TAILS

DRAWING NUMBER:
 M90-602XX45

SHT 2 OF 2