

REVISIONS		
ISS	ZONE	DESCRIPTION\PER REQUEST\DATE
A2	D-3	APPEARANCE WAS CHANGED\N/A\04-03-03'
B	A-3	NO.4 WAS CHANGED\RD-DM93031901L\03-19-04'
B1	D-3	NO.1 WAS CHANGED\N/A\06-30-05'

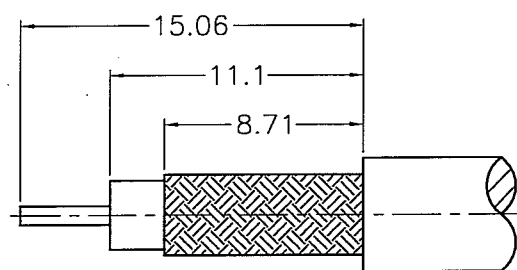

RECOMMENDED
CABLE STRIPPING DIM'S
(建議剝線尺寸)

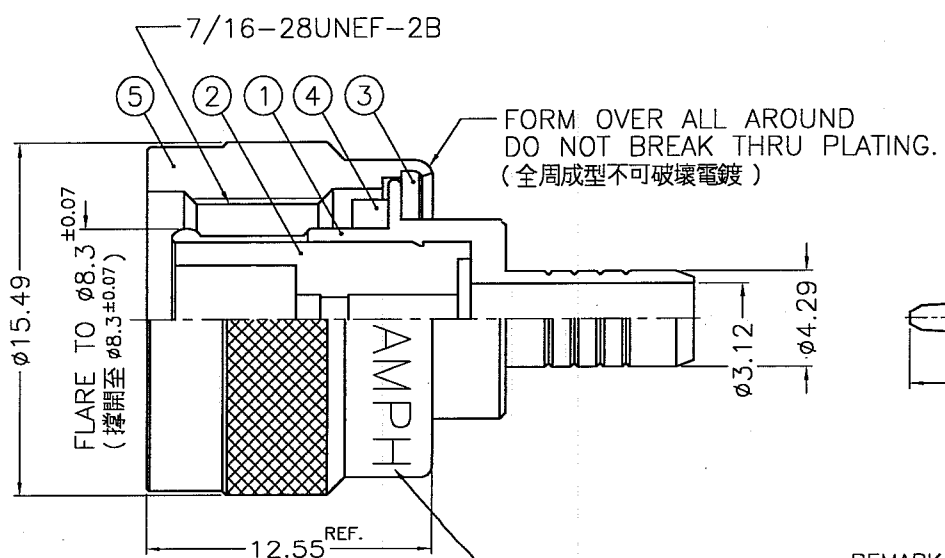
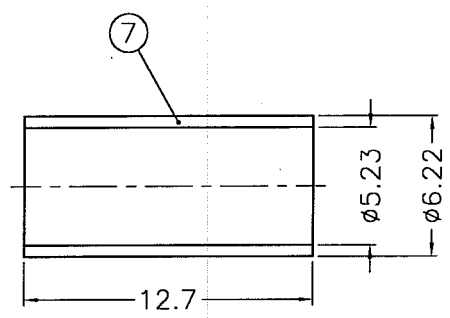
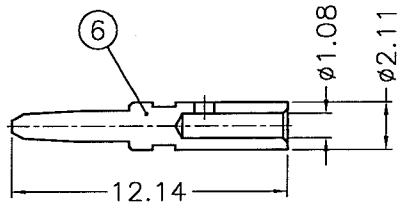

STAMP "AMPHENOL 36825" IN
1.6mm HIGH DEPRESSED CHARACTERS
(戳字 "AMPHENOL 36825" 字高 1.6mm)

- REMARK: 1. WHEN CRIMPING CONTACT PIN TO CABLE, CRIMP WITH AMPHENOL TOOL 227-944 (M22520/5-01) AND DIE SET 227-1221-11, CAVITY 'B' (M22520/5-11, CLOSURE 'B') (內導體壓著工具)
2. WHEN CRIMPING FERRULE TO CABLE, CRIMP WITH AMPHENOL TOOL 227-944 (M22520/5-01) AND DIE SET 227-1221-11, CAVITY 'A' (M22520/5-11, CLOSURE 'A') (套管壓著工具)

- NOTES: FINISH (PLATING THICKNESS IN MICRO-INCHES)
- BRASS PER QQ-B-626
 - BRASS PER QQ-B-613
 - NICKEL PL. 100 MIN. THICK OVER COPPER STRIKE
 - GOLD PL. 50 MIN. THICK OVER NICKEL PL. 100 MIN. THICK OVER COPPER STRIKE
 - TEFLON MIL-P-19468

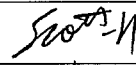
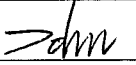
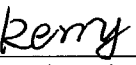
DIMENSIONS ARE IN MILLIMETERS					PART NO.		<h3>Amphenol</h3> Danbury,CT,USA-Tainan,Taiwan-Shenzhen,China				
UNLESS OTHERWISE SPECIFIED TOLERANCES					APPROVED	DATE			TITLE		
7	FERRULE	COPPER	NOTE 3	1	31-1357-5		06-30-05'	TNC PLUG QUICK CRIMP (FOR RG-58/U, 141/U CABLE)			
6	CONTACT PIN	NOTE 1	NOTE 4	1	31-10060-1				CHECKED	DATE	
5	SHELL	NOTE 1	NOTE 3	1	31-10684-1		06-30-05'	DRAWING NO.			
4	GASKET	SILICONE	RED	1	GS-105/8X15S			DRAWN	DATE	36825	
3	WASHER	NOTE 2	NOTE 3	1	WS-12B/9X08		06-30-05'	ITEM NO.			
2	INSULATOR	NOTE 5	NATURAL	1	31-20018			36825			
1	BODY	NOTE 1	NOTE 3	1	31-12088-1						
NO.	DESCRIPTION	MATERIAL	FINISH	Q'TY	DRAWING NO.	SCALE	3/1	ISSUE	B1	FILE NO.	F:\DWG\CNPD\36825-B1SZ