

Aug.1.2018 Copyright 2018 HIROSE ELECTRIC CO., LTD. All Rights Reserved.  
 In case that the application demands a high level of reliability, such as automotive,  
 please contact a company representative for further information.

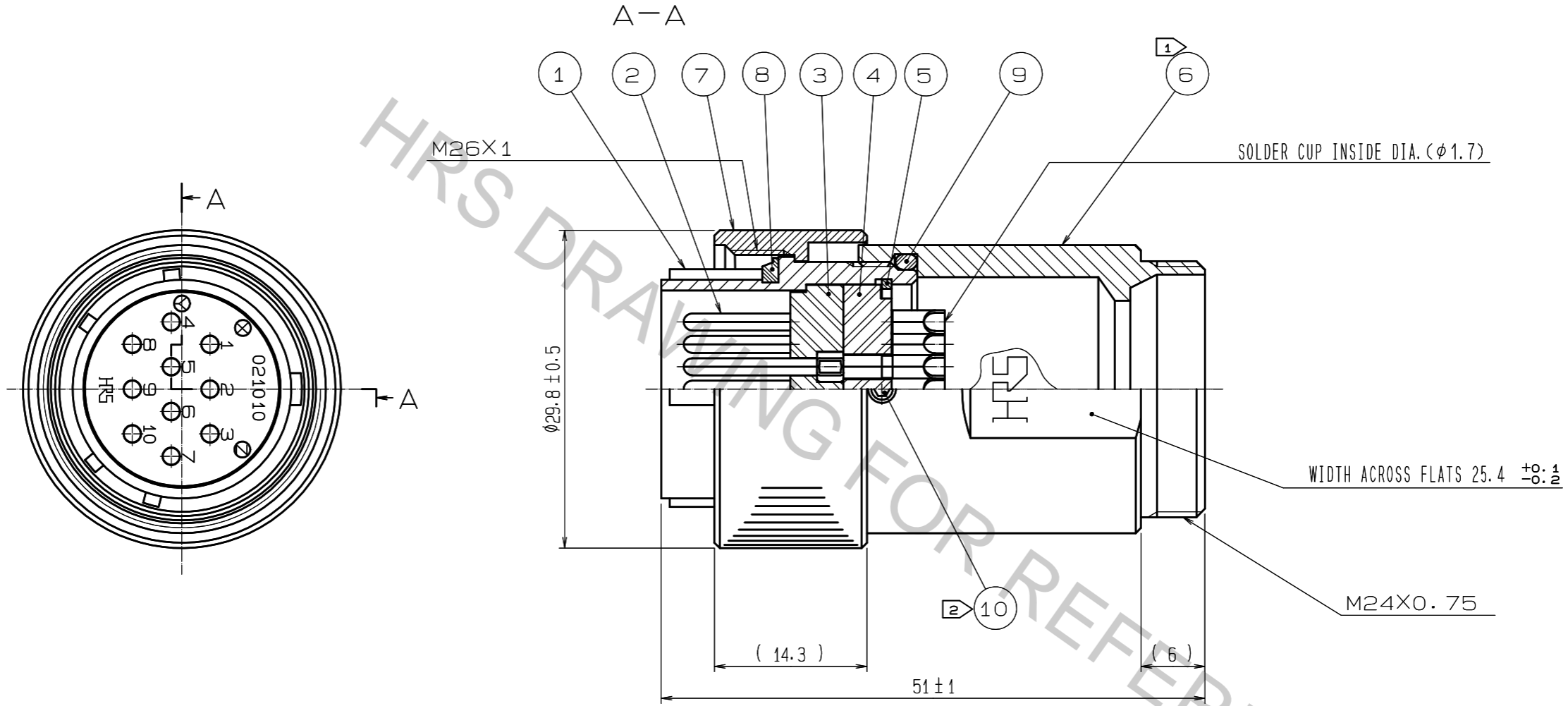

- NOTES
- ① THE RECOMMENDED CLAMP TORQUE OF REF. NO. ⑥ TO BE 4 TO 4.5 N·m.
  - ② THE RECOMMENDED CLAMP TORQUE OF REF. NO. ⑩ TO BE 0.2 TO 0.25 N·m.
  - ③ ROTATION EXAMPLES OF REF. NOS. ① AND ⑥ ARE SHOWN.
  - ④ SCREW OF REF. NO. ①, ⑥, ⑩, LOCTITE 263 OR EQUIVALENT, HENKEL JAPAN IS RECOMMENDED TO PREVENT FROM LOOSENING.
  - ⑤ THIS PRODUCT TO BE USED WITH CABLECLAMP, JR21WCC-\*.  
 \* DESIGNATE DIAMETER OF APPLICABLE CABLE.

NO.	MATERIAL	FINISH, REMARKS	NO.	MATERIAL	FINISH, REMARKS
5	PHOSPHOR BRONZE	NICKEL PLATING	10	STAINLESS STEEL	
4	PHENOL-FORMALDEHYDE	(BLACK) UL94V-0	9	NBR	(BLACK)
3	PHENOL-FORMALDEHYDE	(BLACK) UL94V-0	8	NBR	(BLACK)
2	COPPER ALLOY	SILVER PLATING 3μm min.	7	BRASS	BLACK CHROME PLATING
1	ALUMINUM ALLOY	BLACK CHROME PLATING	6	BRASS	BLACK CHROME PLATING

UNITS	SCALE	COUNT	DESCRIPTION OF REVISIONS	DESIGNED	CHECKED	DATE
mm	2 : 1	△				
HIROSE ELECTRIC CO., LTD.			APPROVED : HY. KOBAYASHI 18.02.26 CHECKED : HY. KOBAYASHI 18.02.26 DESIGNED : TH. KAMEYA 18.02.22 DRAWN : MK. INOUE 18.02.13	DRAWING NO. EDC-110481-31-00 PART NO. JR21WP-10P(31) CODE NO. CL114-2005-6-31	1/1	