

## Model 5344 & Assembly Instructions BNC (Female) Crimp Style Coaxial Connector For Use W/RG58, RG58A, RG58C, RG141 & RG141A

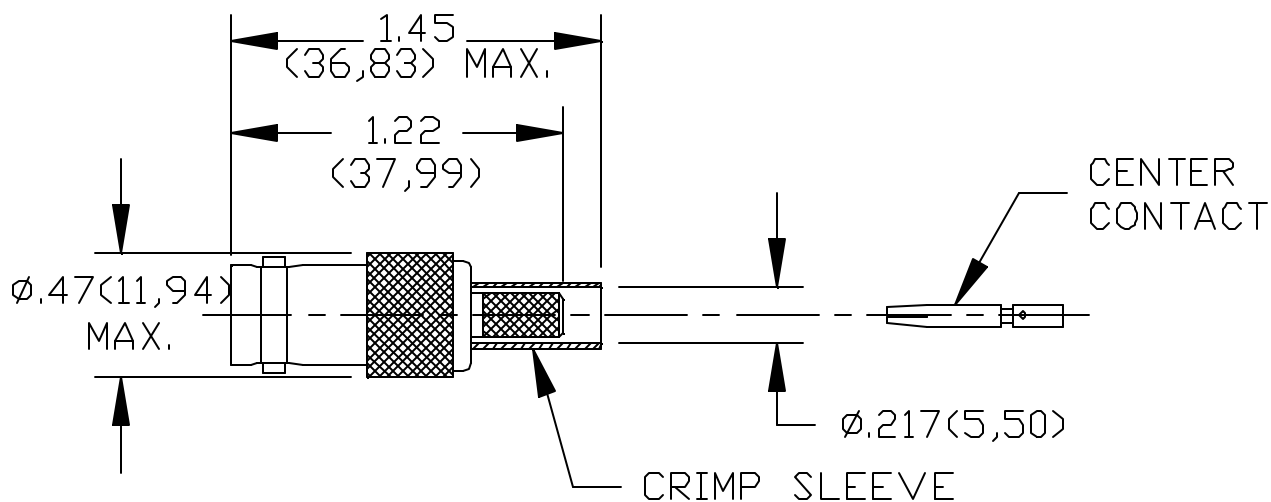

### MATERIALS:

Body: Brass, Tarnish Resistant Plating

Center Contact: Gold Plated Beryllium Copper

Dielectric: PTFE

Cable Group Compatibility: RG/U: 58, 58A, 58C, 141 and 141A

Connector meets the interface requirements of MIL-STD-348

### RATINGS:

Operating Voltage: 500 VRMS Max.

Nominal Impedance: 50 Ohms

### ORDERING INFORMATION: Model 5344

All dimensions are in inches. Tolerances (except noted): .xx =  $\pm .02$ " (.51 mm), .xxx =  $\pm .005$ " (.127 mm).

All specifications are to the latest revisions. Specifications are subject to change without notice.

Registered trademarks are the property of their respective companies.

Made in USA

## Model 5344 & Assembly Instructions BNC (Female) Crimp Style Coaxial Connector For Use W/RG58, RG58A, RG58C, RG141 & RG141A

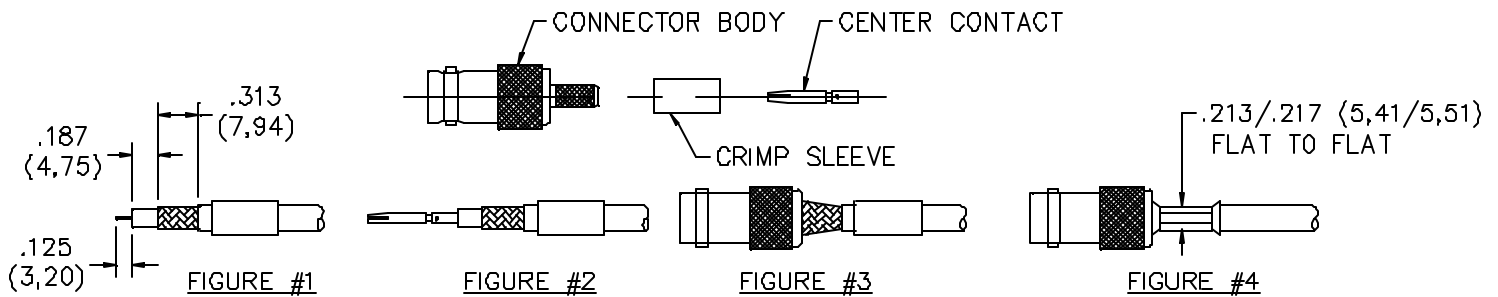

### FIGURE #1

A. Strip cable as shown.

### FIGURE #2

B. Fit the center contact over conductor wires, slide until it butts against the dielectric. Crimp or solder.

### FIGURE #3

C. Slide the metal crimp sleeve over cable, then install the connector body until contact locks into connector.

D. Verify that the knurled ferrule of connector is inserted between the dielectric and the braid.

### FIGURE #4

E. Slide the metal sleeve along the cable unit until it butts against the bottom of connector.

F. Crimp sleeve using Hex type Die or equivalent.

G. Retention after crimp is normally 60 lbs./Minute.

Note: Hex Diameter .213/.217 after crimp.

All dimensions are in inches. Tolerances (except noted): .xx = ±.02" (.51 mm), .xxx = ±.005" (.127 mm).

All specifications are to the latest revisions. Specifications are subject to change without notice.

Registered trademarks are the property of their respective companies.

Made in USA