



PSR-TRISAFE system: Configurable safety modules and safe extension modules

User manual

User manual

PSR-TRISAFE system: Configurable safety modules and safe extension modules

UM EN PSR-TRISAFE system, revision 02

2017-12-08

This user manual is valid for:

	Designation	Revision as of HW/FW	Order No.
PSR-TRISAFE-S	PSR-SCP-24DC/TS/S	10/1636	2986229
	PSR-SPP-24DC/TS/S	10/1636	2986232
PSR-TRISAFE-M	PSR-SCP-24DC/TS/M	10/2033	2986012
	PSR-SPP-24DC/TS/M	10/2033	2986025
PSR-TS-SDI8-SDIO4	PSR-SCP-24DC/TS/SDI8/SDIO4	10/1021	2986038
	PSR-SPP-24DC/TS/SDI8/SDIO4	10/1021	2986041
PSR-TS-SDOR4	PSR-SCP-24DC/TS/SDOR4/4x1	02/1002	2986096
	PSR-SPP-24DC/TS/SDOR4/4x1	02/1002	2986106

This user manual uses the following designations:

Safety modules:

Designation for the PSR-TRISAFE-S and PSR-TRISAFE-M modules

Safe extension modules:

Designation for the PSR-TS-SDI8-SDIO4 and PSR-TS-SDOR4 modules

Table of contents

1	For your safety	7
1.1	Marking of warning notes.....	7
1.2	Qualification of users	7
1.3	Field of application of the product.....	8
1.3.1	Intended use	8
1.3.2	Product changes	9
1.4	Safety notes.....	9
1.4.1	General safety notes	9
1.4.2	Electrical safety	11
1.4.3	Safety of machines or systems	12
1.4.4	Safety when starting applications	13
1.5	Directives and standards	13
1.6	Documentation	14
1.7	Safety hotline.....	14
2	System description	15
2.1	PSR-TRISAFE safety system: Structure and method of operation	15
2.2	Using the system	18
2.3	Safe state	19
2.4	System startup and restart behavior	19
2.5	Error detection	21
2.6	Error state	21
2.7	Diagnostic tools	22
2.8	Password protection	22
3	PSR-TRISAFE-S and PSR-TRISAFE-M safety modules	23
3.1	Product description.....	23
3.1.1	Connecting extension devices	25
3.2	Operating modes (status) of the safety modules	26
3.3	Operating and indication elements	27
3.3.1	Diagnostics and status indicators	27
3.3.2	Confirm button	28
3.3.3	USB interface	28
3.3.4	IFS-CONFSTICK	30
3.4	Signal connections	31
3.4.1	Safe inputs	31
3.4.2	Safe outputs	32
3.4.3	Signal outputs	33
3.4.4	Clock outputs	33
3.4.5	Ground switching outputs	34
3.4.6	Supply connections	34

4	PSR-TS-SDI8-SDIO4 safe extension module	37
4.1	Product description.....	37
4.3	Signal connections	39
4.3.1	Safe inputs	39
4.3.2	Safe outputs	40
4.3.3	Clock/signal outputs	40
4.3.4	Supply connections	42
5	PSR-TS-SDOR4 safe extension module	43
5.1	Product description.....	43
5.3	Signal connections	46
5.3.1	Safe relay outputs	46
5.3.2	Signal outputs	48
5.3.3	Supply connections	48
6	Wiring examples	51
6.1	Notes on the wiring examples.....	51
6.2	Single-channel assignment of safe digital inputs	51
6.2.1	Cross-circuit monitoring enabled	51
6.2.2	Cross-circuit monitoring disabled, external supply	52
6.2.3	External supply (OSSD)	53
6.3	Two-channel equivalent assignment of safe digital inputs	54
6.3.1	Cross-circuit monitoring enabled, supply through T0 and T1	54
6.3.2	Cross-circuit monitoring disabled, external supply	55
6.3.3	External supply (OSSD)	56
6.4	Two-channel non-equivalent assignment of safe digital inputs	57
6.4.1	Cross-circuit monitoring enabled, supply through T0 and T1	57
6.4.2	Cross-circuit monitoring disabled, external supply	58
6.5	Safe digital outputs	59
6.5.1	Notes on the protective circuit for external relays/contactors (freewheeling circuit)	59
6.5.2	Single-channel assignment of safe digital outputs	60
6.5.3	Two-channel assignment of safe digital outputs	61
6.6	Safe relay outputs.....	62
6.6.1	Notes on the protective circuit for external relays/contactors (freewheeling circuit)	62
6.6.2	Single-channel assignment of safe relay outputs	62
6.6.3	Two-channel assignment of safe relay outputs	63

7	Assembly, removal, and electrical installation	65
7.1	Safety notes on assembly, removal and electrical installation	65
7.2	Assembly	66
7.2.1	Assembly instructions	66
7.2.2	Mounting location	66
7.2.3	Mounting work	67
7.3	Dismantling.....	68
7.4	Electrical installation	69
7.4.1	Connecting signal lines	70
7.4.2	Connecting the supply voltage	72
7.4.3	Typical connection of a PSR-TRISAFE system	75
8	Firmware update	77
8.1	Safety notes for the firmware update	77
8.2	Requirements for firmware update.....	78
8.3	Updating the firmware.....	78
9	SAFECNF configuration software	79
9.1	Installing the software	79
9.2	Accessing the software help	80
10	Configuration and startup	81
10.1	Example for configuration and startup	81
10.2	Downloading configuration from the SAFECNF configuration software	84
10.3	Downloading the configuration using the IFS-CONFSTICK memory module	88
10.4	Uploading the configuration from the safety module	90
10.5	Function test.....	91
10.5.1	Performing function test using online mode	91
11	Diagnostics	93
11.1	Diagnostics using LED indicators on the module.....	93
11.1.1	PSR-TRISAFE-S and PSR-TRISAFE-M	94
11.1.2	PSR-TS-SDI8-SDIO4	97
11.1.3	PSR-TS-SDOR4	98

12	Problems and solutions	99
12.1	General.....	99
12.2	Graphical connection editor.....	99
12.3	Parameterization editor.....	100
12.4	Online communication between SAFECONF and the safety module	101
12.5	Communication between the safety module and the safe extension module.....	103
12.6	Safety module messages	103
13	Maintenance, repair, decommissioning, and disposal	105
13.1	Maintenance.....	105
13.2	Repair.....	105
13.3	Decommissioning and disposal.....	105
14	Technical data and ordering data	107
14.1	Technical data of the PSR-TRISAFE-S and PSR-TRISAFE-M	107
14.2	Technical data of PSR-TS-SDI8-SDIO4	113
14.3	Technical data of PSR-TS-SDOR4	118
14.4	Approvals	124
14.5	Conformance with EMC Directive.....	124
14.6	System requirements of the configuration software SAFECONF.....	125
14.7	Ordering data.....	126
14.7.1	PSR-TRISAFE modules	126
14.7.2	Software	126
14.7.3	Accessories	127
14.7.4	Gateways	128
14.8	Documentation	129
A	Technical appendix.....	131
A 1	Calculating the power dissipation	131
A 2	Shutdown time of the PSR-TRISAFE system	135
A 3	Using PSR-TRISAFE modules at altitudes greater than 2000 m above sea level.....	136
B	Appendix for document lists.....	139
B 1	List of figures	139
B 2	List of tables	143
B 3	Index.....	145
C	Revision history	149

1 For your safety

Read this user manual carefully and keep it for future reference.

1.1 Marking of warning notes



This symbol indicates hazards that could lead to personal injury. There are three signal words indicating the severity of a potential injury.

DANGER

Indicates a hazard with a high risk level. If this hazardous situation is not avoided, it will result in death or serious injury.

WARNING

Indicates a hazard with a medium risk level. If this hazardous situation is not avoided, it could result in death or serious injury.

CAUTION

Indicates a hazard with a low risk level. If this hazardous situation is not avoided, it could result in minor or moderate injury.



This symbol together with the **NOTE** signal word warns the reader of actions that might cause property damage or a malfunction.



Here you will find additional information or detailed sources of information.

1.2 Qualification of users

The use of products described in this user manual is oriented exclusively to:

- Electrically skilled persons or persons instructed by them. The users must be familiar with the relevant safety concepts of automation technology as well as applicable standards and other regulations.
- Qualified application programmers and software engineers. The users must be familiar with the relevant safety concepts of automation technology as well as applicable standards and other regulations.

1.3 Field of application of the product

Only use the PSR-TRISAFE system in accordance with the area of application described in this section.

1.3.1 Intended use

Use the safety modules and safe extension modules of the PSR-TRISAFE system only in accordance with the information provided in this section.

PSR-TRISAFE system

The intended use for the PSR-TRISAFE system is safe switch-off. Safe switch-on does **not** fall under the intended use.

All modules of the PSR-TRISAFE system are intended for use in industrial applications.

The safety modules and safe extension modules can only perform their safety-related tasks if they have been integrated into the execution process correctly and in such a way as to avoid errors.

You must observe all information in this user manual as well as the user manuals and help listed in "Documentation" on page 14.

Only use the modules of the PSR-TRISAFE system in acc. with the provided technical data. See Section 14 „Technical data and ordering data“ from page 107.

For more information on using the PSR-TRISAFE system, refer to "Using the system" on page 18.

PSR-TRISAFE-S and PSR-TRISAFE-M

The PSR-TRISAFE-S and PSR-TRISAFE-M modules are configurable safety modules with 20 safe inputs and four safe outputs. The inputs are for analyzing signal generators that are relevant to safety, e.g. emergency stop buttons or safety doors. Safety-related circuits are interrupted via the outputs. Additionally, four signal outputs, two clock outputs and two ground switching outputs are available.

The PSR-TRISAFE-S safety module is a standalone device and cannot be combined with safe extension modules.

The PSR-TRISAFE-M safety module can be supplemented with safe inputs and outputs by means of safe extension modules of the PSR-TRISAFE system.

At both safety modules, you can connect a gateway for transmitting diagnostic data.

PSR-TS-SDI8-SDIO4

The PSR-TS-SDI8-SDIO4 safe extension module is an extension to the PSR-TRISAFE-M safety module. With it, the following additional inputs and outputs are available: four configurable inputs or outputs, two configurable clock or signal outputs, as well as eight safe inputs.

PSR-TS-SDOR4

The PSR-TS-SDOR4 safe extension module is an extension to the PSR-TRISAFE-M safety module. With it, four additional safe relay outputs and four signal outputs are available.

SAFECONF

The SAFECONF safe configuration software is intended for configuring the safety modules and the connected extension modules.

Safe functional blocks and functions in SAFECONF

The SAFECONF configuration software provides you with safe functional blocks and functions for creating the safety logic. These are designed solely for use within the safety module and support specific safety functions.

The safe functional blocks and functions can only perform their safety-related tasks within the safe control system if they have been integrated into the execution process correctly and in such a way as to avoid errors.

1.3.2 Product changes

Modifications to hardware and firmware of the device are not permitted.

Incorrect operation or modifications to the device can endanger your safety or damage the device. Do not repair the device yourself. If the device is defective, please contact Phoenix Contact.

1.4 Safety notes

1.4.1 General safety notes



WARNING: Severe danger due to improper use

Depending on the application, inappropriate use of the PSR-TRISAFE system may pose serious risks for the user.

- Observe the safety notes in this Section.
- Observe the warning instructions provided elsewhere in this document.

Documentation



Observe all information in this user manual and the accompanying documents. See Section "Documentation" on page 14.

Safety of personnel and equipment

The safety of personnel and equipment can only be assured if the modules and the safe blocks are used correctly:
See Section "Intended use" on page 8.

Qualified personnel

In terms of this user manual, qualified personnel are persons who, because of their education, experience and instruction, and their knowledge of relevant standards, regulations, accident prevention, and service conditions, have been authorized to carry out any required operations, and who are able to recognize and avoid any possible dangers.

In the context of the use of the PSR-TRISAFE system with SAFECONF configuration software and safe functional blocks, the following operations may only be carried out by qualified personnel:

- Planning, parameterization, configuration (development of the safety logic)
- Installation, startup, servicing
- Maintenance, decommissioning

Requirements

Knowledge of the following topics and products is required:

- The safety modules and safe extension modules of the PSR-TRISAFE system that are used
- The periphery used (extension devices, sensors, actuators)
- Operation of the SAFECONF configuration software
- Safety technology systems
- Safety regulations in the field of application

PSR-TRISAFE system

Error detection

Depending on the wiring and the parameterization, the safety modules and safe extension module of the PSR-TRISAFE system detects errors within the safety equipment.

Do not open the housing

It is prohibited to open the module housing. If the housing is opened, the function of the PSR-TRISAFE modules can no longer be ensured.

Mismatching and polarity reversal of connections

Take measures to prevent the incorrect connection, polarity reversal, and manipulation of connections.

The individual terminal block bases of all PSR-TRISAFE modules are mechanically coded to prevent confusion or connecting them the wrong way round.

1.4.2 Electrical safety



WARNING: Loss of safety function/hazardous shock currents

Incorrect installation can result in the loss of the safety function as well as hazardous shock currents. Depending on the application, there may be serious risks for the user.

- Observe the notes on electrical safety.
- Observe the warning instructions provided elsewhere in this document.
- Plan the devices used and their installation in the system in accordance with the specific requirements.
- Recheck plants and systems that have been retrofitted with the safety relay module.
- Pay attention to the information in the user documentation of other devices used (e.g. sensors, actuators or extension devices).

Direct/Indirect contact

Protection against direct and indirect contact in accordance with VDE 100 Part 410 must be ensured for all components connected to the system. In the event of an error, parasitic voltages must not occur (single-fault tolerance).

Measures required:

- Using power supply units with safe isolation (PELV)
- Decoupling circuits, which are not PELV systems
With following components: optocouplers, relays, and other components which meet the requirements of safe isolation

Safe isolation

Only use devices with safe isolation if dangerous contact voltages can occur at their connections.

Power supply units for 24 V supply

Only use power supply units with safe isolation and PELV in accordance with EN 50178/VDE 0160. This prevents short circuits between primary and secondary sides.

Connect the GND connection on the output side of the power supply unit to the functional earth ground (FE) of the system.

Ground contact

Make sure that all inputs and outputs of the system are connected to the same ground.

Insulation rating

When selecting the equipment, please take into consideration the dirt and surge voltages which may occur during operation. If necessary, implement additional measures for voltage limitation.

Installation space and mounting position

Observe the requirements for installation space and mounting position as specified in the technical data.

ESD



NOTE: Electrostatic discharge

Electrostatic discharge can damage or destroy components. When handling the device, observe the necessary safety precautions against electrostatic discharge (ESD) according to EN 61340-5-1 and IEC 61340-5-1.

1.4.3 Safety of machines or systems

The machine/system manufacturer and the operator are responsible for the safety of the machine or system and the application in which the machine or system is used.

Draw up and implement a safety concept

In order to use the system described in this document with the associated safe functional blocks, you must have drawn up an appropriate safety concept for your machine or system. This includes a hazard and risk analysis in acc. with the directives and standards specified in Section "Directives and standards" on page 13.

The target safety integrity is ascertained on the basis of the risk analysis.

- SIL in acc. with IEC 61508
- SILCL in acc. with EN 62061
- Cat./PL in acc. with EN ISO 13849-1

The following depends on the identified safety integrity level:

- The wiring of safe sensors, control devices and actuators within the overall safety function
- The use of safe blocks in the safety logic
You can create the safety logic with the aid of the SAFECONF configuration software.

Safety-related equipment

In order to use the PSR-TRISAFE system properly, safety-related equipment must be provided on the machine.

This includes, for example:

- Emergency stop button
- Protective cover switch
- Enable switch
- Light grid

Checking hardware and parameterization

Carry out a validation every time you make a safety-related modification to your overall system.

Use the relevant checklists when carrying out the validation. Also enter the details requested in the "Project Information" dialog box in the SAFECONF safe configuration software.

Use your test report to ensure that:

- Are the safe sensors and actuators connected correctly in the PSR-TRISAFE safety application? To do this, also use the "Wiring check" function in the SAFECONF configuration software.
- Is the parameterization of the inputs and outputs of the safety modules and the safe extension modules correct?
- Have the signals been connected to the safe sensors and actuators correctly (single-channel or two-channel)?
- Is the cross-circuit detection implemented in your application, if required (see page 22)?
- Are all safe functional blocks and functions in the SAFECONF configuration software connected correctly?

Connecting USB connection

For safe operation of the machine or system, no USB connection to the safety modules may exist.

For further information, please refer to Section "USB interface" on page 28.

1.4.4 Safety when starting applications

Take the following into consideration when determining the start conditions for your machine or system:

- The machine or system may only be started if it has been ensured that no one is present in the danger zone.
- Meet the requirements of EN ISO 13849-1 with regard to the manual reset function.

This applies to:

- Switching on safe devices
- Acknowledging device error messages
- Removing startup inhibits for safety functions

Observing startup behavior

Some of the safe functional blocks in the SAFECONF configuration software have parameters for specifying a startup inhibit and/or a restart inhibit.

For further information, please refer to Section “System startup and restart behavior” on page 19.

1.5 Directives and standards

The standards that are complied with by the PSR-TRISAFE system can be found in the certificate of the registration office and the EC declaration of conformity.

These documents are available on the Internet.

See phoenixcontact.net/products.

1.6 Documentation

Latest documentation

Always use the latest documentation. Changes or additions to documentation can be found on the Internet.

See phoenixcontact.net/products.

You must observe all information from the following sources:

- Technical description of the safety modules
- Technical description of the safe extension modules
- User documentation for I/O devices (e.g., sensors/actuators, etc.) connected to the PSR-TRISAFE modules and connected to safe functional blocks in the safety logic (SAFECONF configuration software)
- Documentation for supplementary standard technology
- Help for SAFECONF safe configuration software and for each of the safe blocks (see “Accessing the software help” on page 80)



For additional information and detailed step-by-step instructions for the SAFECONF configuration software, please refer to the online help of the software.

1.7 Safety hotline

Should you have any technical questions, please contact our 24-hour hotline.

Phone: +49 5281 9462777

E-mail: safety-service@phoenixcontact.com

2 System description

2.1 PSR-TRISAFE safety system: Structure and method of operation

Overall system: Hardware and software

The PSR-TRISAFE safety system consists of the following components.

When using the PSR-TRISAFE-S safety module:

- PSR-TRISAFE-S safety module
- SAFECONF configuration software
- Safe control devices, sensors and actuators (depending on the application)

When using the PSR-TRISAFE-M safety module:

- PSR-TRISAFE-M safety module
- Optional, safe PSR-TS-SDI8-SDIO4 / PSR-TS-SDOR4 extension module
- SAFECONF configuration software
- Safe control devices, sensors and actuators (depending on the application)

The diagram below illustrates the overall system in an example of use with the PSR-TRISAFE-M.

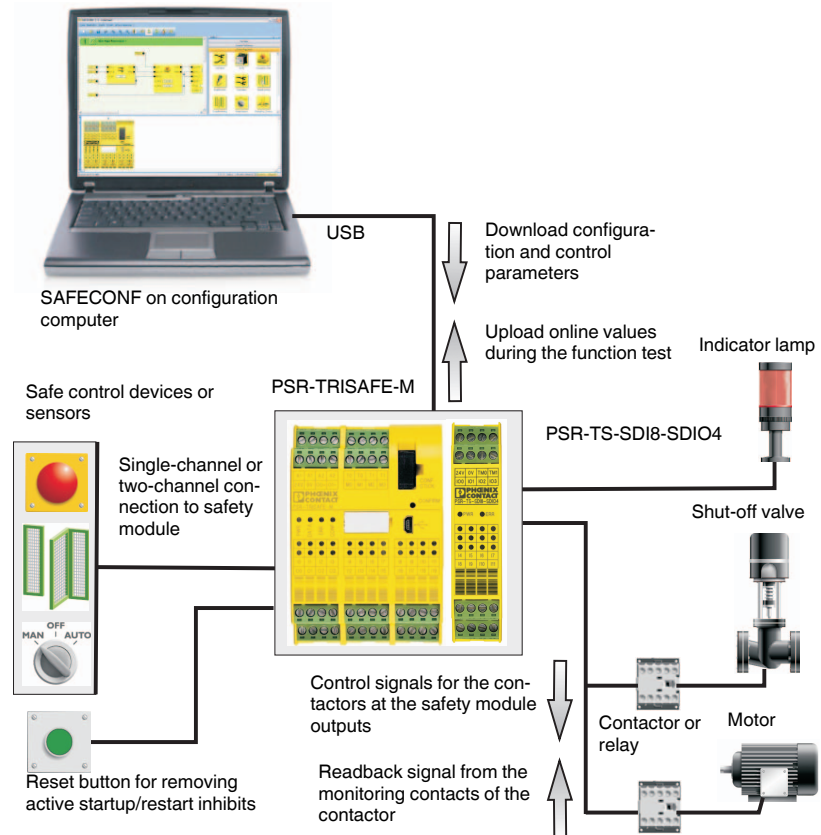

Figure 2-1 Example structure of a safety system with PSR-TRISAFE-M

Communication via USB

The USB interface is used for communication between the PSR-TRISAFE-S or PSR-TRISAFE-M safety modules and the configuration software.

**WARNING: Standard operation**

The USB interface is not ESD protected. When there is a USB connection, the safety module is in standard operation mode. The safety function cannot be executed properly.

- Use the USB connection for startup only.
- Disconnect the USB connection for regulator operation.

The safety module and configuration software PC communicate in both directions:

PC → Safety module

The configuration data and device parameters are downloaded from the configuration PC to the safety module. Configuration data refers to the application logic which you created using the SAFECNF configuration software.

You can also download the configuration by means of the pluggable IFS-CONFSTICK memory module. Please refer to “Downloading configuration from the SAFECNF configuration software” on page 84 and “Downloading the configuration using the IFS-CONFSTICK memory module” on page 88.

Safety module → PC

For diagnostic purposes, online values can be read from the safety module via the USB interface and displayed “live” in the software. For more detailed information, please refer to “Function test” on page 91.

Communication via DIN rail connector

The PSR-TRISAFE-S safety module is equipped with an interface for the yellow PSR-TBUS DIN rail connector. The PSR-TRISAFE-M safety module has two interfaces for the yellow PSR-TBUS.

In combination with the green TBUS DIN rail connector, connect max. one standard extension device (gateway) to the PSR-TRISAFE-S or PSR-TRISAFE-M safety module.

At the PSR-TRISAFE-M safety module, connect up to ten safe extension modules additionally by using more yellow PSR-TBUS DIN rail connectors.

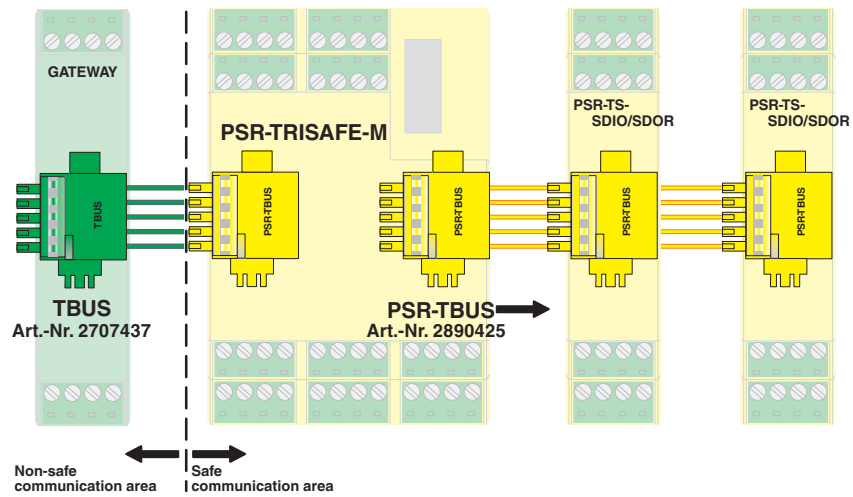

Figure 2-2 Safety module extension PSR-TRISAFE-M



Other standard bus devices are possible. For more information, refer to the user documentation of the gateway used, under phoenixcontact.net/products.

Communication between the safety modules and the standard or safe extension modules is automatically performed via the connectors of the DIN rail connector. See also Section "Assembly" on page 66.



NOTE: Wear on the connectors

Up to eight mating cycles are permitted for connecting the modules by means of the DIN rail connector.



Observe the maximum continuous current for extension modules supplied via the PSR-TBUS, as well as the technical data of the PSR-TRISAFE system. See Section "Technical data and ordering data" on page 107.

2.2 Using the system

Safety circuits

The safety modules of the TRISAFE system offer flexible configuration. For the creation of the safety logic, the system has safe functional blocks. With the TRISAFE system, you can implement various safety functions in different safety circuits. Some of the most important options are:

- Emergency stop monitoring
- Safety door monitoring (with and without locking)
- Two-hand controls (type II and III)
- External device monitoring (EDM)
- Monitoring and checking electro-sensitive protective equipment
- Mode selector switch (evaluation of a mode selector switch and an enable switch)
- Muting applications (light grid monitoring with parallel muting)



Examples of use:

In the help of the SAFECONF configuration software, you can find examples of use for the safe functional blocks, with typical applications for each block.

The safety logic configured in the configuration software, as well as the wiring of the safety modules and the safe extension modules, is displayed in the form schematic diagrams.

The online help also includes typical signal sequence diagrams which illustrate the behavior of each function block.

The following examples of use are included in the online help for the functional blocks:

- Single-channel and two-channel emergency stop circuits
- Single-channel and two-channel safety door monitoring, with and without interlocking
- Mode selector switch selection with interlocking of the set operating mode and manual operating mode acknowledgment
- Evaluation of a three-position enable switch with confirmation of the selected safe operating mode
- Parallel muting with two sensors
- Evaluation of a light curtain connected via a single channel
- Type II and Type III two-hand control devices

2.3 Safe state

The safe state of an output terminal point is power off mode (signal value: "0").

TRISAFE system can enter a safe state in the following cases:

1. Operating state (by triggering the safety function)
2. Error detection in I/O devices
3. Device error
4. Parameterization error
5. Error detection during safe communication

2.4 System startup and restart behavior



WARNING: Unintentional machine startup

Startup/restart following power up and when there is no longer a demand of the safety function can result in unintentional machine startup.

- Please note the following:
 - After the configuration has been completed, the module immediately starts up.
 - The module immediately starts up again once the trigger for the safety function has been reset.
- If you do not want the machine to start up/restart automatically, configure the startup/restart behavior accordingly in the safety logic.

Startup

"Startup" refers to the behavior of the PSR-TRISAFE-S or PSR-TRISAFE-M safety modules and the optional safe extension modules after switching on or applying supply voltage and following configuration via USB interface or IFS-CONFSTICK.

Unless a startup inhibit is configured, the safety module starts up immediately following successful configuration (i.e., after the "Confirm" button has been pressed). The safe inputs are evaluated and the outputs controlled accordingly.

Restart

"Restart" refers to the behavior of the safety modules and the optional safe extension modules after the safety function is triggered and following a return to normal operation. The return to normal operation is for example achieved by unlocking the emergency stop control device once safe operation is possible again.

With an active startup/restart inhibit, the corresponding safe module output remains in the safe state. This prevents unintentional startup/restart of a machine controlled via the relevant output.

Reset button



WARNING: Unintentional machine startup

The acknowledgment of an error immediately returns the safe input or output to the operating state.

- Before acknowledging an error you must make sure that the acknowledgment will not cause the machine to switch to a hazardous state.
- When planning the machine or system, make sure that acknowledgment is only possible if the danger zone is visible.



With the manual reset function, a machine start may not be triggered in accordance with EN ISO 13849-1.

An active startup inhibit/restart inhibit can be removed by pressing a reset button that is connected and appropriately wired to the safety module or to the safe extension modules.

The reset signal is simultaneously used to exit the error state once the error cause has been removed.

Implementation using safe functional blocks

To implement a startup inhibit/restart inhibit, you use the safe functional blocks in the SAFECNF configuration software which have the relevant parameters for activating the startup inhibit and/or restart inhibit.

To configure a startup inhibit for a specific safe output, for example, this output must be directly linked in the safety logic to the output of a safe function block, for which a startup inhibit is set via the parameters.



For more information on implementing a startup/restart inhibit, refer to the help of the SAFECNF configuration software.

2.5 Error detection

Depending on the wiring and the parameterization, the safety modules and safe extension modules of the PSR-TRISAFE system detects the following errors at the safe inputs and outputs:

- Short circuit of outputs
- Cross-circuit of inputs or outputs
- Overload at the outputs

2.6 Error state

Stop category 1 only in error-free state



NOTE: Immediate shutdown could cause material damage.

The device only ensures stop category 1 during **error-free operation**. In the event that the supply voltage is lost or an internal error occurs, the device behaves in acc. with stop category 0.

- Do **not** use the device for applications in which stop category 1 also has to be observed in the event of an error.

Operating time in the error state



WARNING: Loss of the safe state in the failure state

In the failure state, internal module tests are no longer run and it is possible that the safe state may be exited due to an accumulation of errors.

- In case the module enters an error state, then assess, acknowledge, or rectify the error within 72 hours.

2.7 Diagnostic tools

SAFECONF diagnostics

Depending on the device, the TRISAFE system modules together with the SAFECONF configuration software provide various tools that can be used to diagnose the active configuration on the safety module:

- Hardware diagnostics in the event of a safe function block error
- Wiring check
- Tooltips in the connection editor
- Diagnostics and status indicators at the module
- Additional diagnostic options using gateways



For information on hardware diagnostics, wiring checks and tool tips, refer to the help of the SAFECONF configuration software.

Diagnostics and status indicators

You can find an overview of the diagnostics and status indicators of the individual modules in the respective section.

- PSR-TRISAFE-S and PSR-TRISAFE-M: see “Diagnostics and status indicators” on page 27.
- PSR-TS-SDI8-SDIO4: See “Diagnostics and status indicators” on page 38.
- PSR-TS-SDOR4: See “Diagnostics and status indicators” on page 45.

Diagnostics via gateways

You can connect your PSR-TRISAFE system to a higher-level controller via gateways. Diagnostics readouts are bus-specific.



For information on gateway diagnostics, refer to the following application note:
 AH EN PSR-TRISAFE System Diagnostics
 See phoenixcontact.net/products.

You can find gateways that are suitable for use with the PSR-TRISAFE system in the accessories section “Gateways” on page 127.

2.8 Password protection

With two passwords, the TRISAFE system and SAFECONF provide double protection against unauthorized changes to the configuration and the project in the configuration software.



For additional information on password protection, refer to the help of the SAFECONF configuration software.

3 PSR-TRISAFE-S and PSR-TRISAFE-M safety modules

The PSR-TRISAFE-S and PSR-TRISAFE-M safety modules are largely identical in function and basic design.



The description of the two safety modules is summarized jointly in this section. Also observe the additional information provided for the PSR-TRISAFE-M and the safe extension module.

Difference between PSR-TRISAFE-S and PSR-TRISAFE-M

The difference between the two safety modules lies in the following properties:

- SAFECONF diagnostics
- Connection option for safe extension modules of the PSR-TRISAFE system

3.1 Product description



Pay attention to the technical data of the safety module. See “Technical data of the PSR-TRISAFE-S and PSR-TRISAFE-M” on page 107.

Safe digital inputs

PSR-TRISAFE-S and PSR-TRISAFE-M are configurable safety modules with 20 safe digital inputs. The inputs are used to connect safe sensors or control devices. The maximum number of sensors/control devices depends on the wiring:

- Single-channel wiring: maximum 20 safe sensors/control devices
- Two-channel wiring: maximum 10 safe sensors/control devices

Safe digital outputs

The safety modules have four safe digital outputs. The outputs are controlled after the incoming signals have been evaluated depending on the configuration.

Ground switching outputs

The safety modules have two ground switching outputs. With the ground switching outputs, you can, for example, switch off a contactor connected to the safety module. The switch-off can be performed via both the 24-V output and ground. Use of the ground switching outputs increases the shutdown protection and cross-circuit protection of the safety circuit.

Digital signal outputs

The safety modules have four non-safety-related digital signal outputs. You can use the signal outputs to control a standard PLC or signaling units, for example.

Safe clock outputs

The safety modules have two clock outputs. Depending on the configuration, the asynchronous test clocks provide safe cross-circuit detection at the inputs of the safety modules.

Connection technology

The safety modules are available with either screw connections or spring-cage connections. All connection terminal blocks can be plugged in. The individual terminal block bases are mechanically coded to prevent confusion or connecting them the wrong way round.

Connection versions

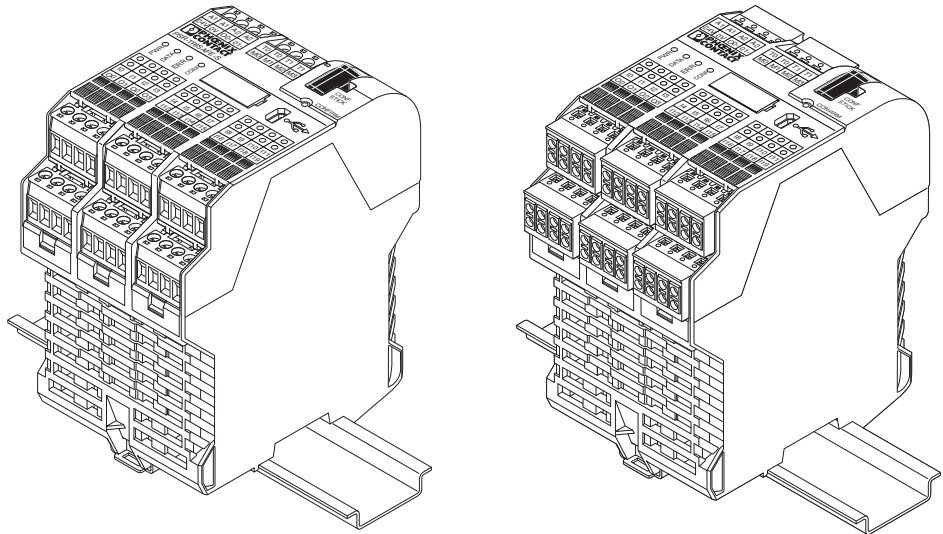

Figure 3-1 Screw terminal blocks (left) and spring-cage terminal blocks (right)

Block diagrams

PSR-TRISAFE-S:

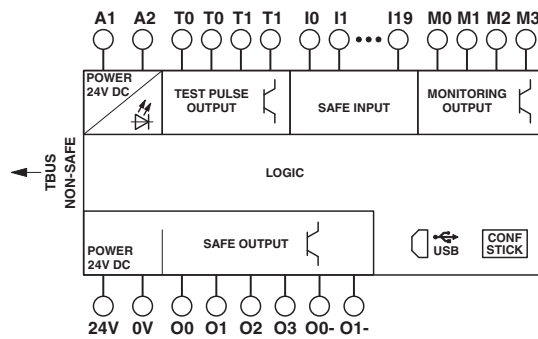

Figure 3-2 Block diagram PSR-TRISAFE-S

PSR-TRISAFE-M:

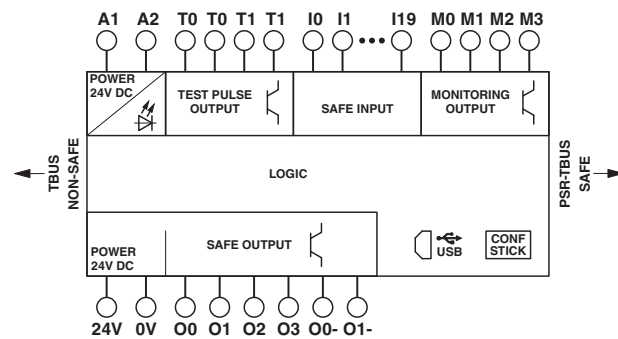

Figure 3-3 Block diagram PSR-TRISAFE-M

Configuration

You can create the configuration of the safety module with the SAFECONF configuration software. Subsequently, you load the configuration into the safety module via the USB interface.



WARNING: Standard operation

The USB interface is not ESD protected. When there is a USB connection, the safety module is in standard operation mode. The safety function cannot be executed properly.

- Use the USB connection for startup only.
- Disconnect the USB connection for regulator operation.

Difference in SAFECONF

In the SAFECONF configuration software, 16 external signals are available for the PSR-TRISAFE-S safety module.

For the PSR-TRISAFE-M safety module, 64 external signals are available. Additionally it is possible to use diagnostic addresses for diagnosing modules.



For additional information regarding the SAFECONF configuration software, refer to Section "SAFECONF configuration software" on page 79 or the Help system provided with the software.

3.1.1 Connecting extension devices



Also read "Communication via DIN rail connector" on page 16.

Connecting standard extension modules (gateways):

**Standard extension:
PSR-TRISAFE-S/-M**

At both safety modules, you can connect max. one gateway for transmitting diagnostic data. Install the gateway on the left next to the safety module.



For information on gateway diagnostics, refer to the following application note:
AH EN PSR-TRISAFE System Diagnostics
See phoenixcontact.net/products.

You can find gateways that are suitable for use with the PSR-TRISAFE system in the accessories section "Gateways" on page 127.

Connecting safe extension modules:

**Safe extension: only
PSR-TRISAFE-M**

Only the PSR-TRISAFE-M safety module can be extended by means of the safe extension modules of the PSR-TRISAFE system. You can install up to ten safe extension modules on the right next to the PSR-TRISAFE-M safety module.



For more information on the safe extension modules, refer to section "PSR-TS-SDI8-SDIO4 safe extension module" on page 37 and "PSR-TS-SDOR4 safe extension module" on page 43.

3.2 Operating modes (status) of the safety modules

The diagram below illustrates the possible operating modes (status) of the PSR-TRISAFE-S and PSR-TRISAFE-M safety modules and the possible status transitions. When there is a USB connection to the PC, the module status is indicated on the far right of the status bar in the SAFECONF configuration software.



WARNING: Standard operation

The USB interface is not ESD protected. When there is a USB connection, the safety module is in standard operation mode. The safety function cannot be executed properly.

- Use the USB connection for startup only.
- Disconnect the USB connection for regulator operation.

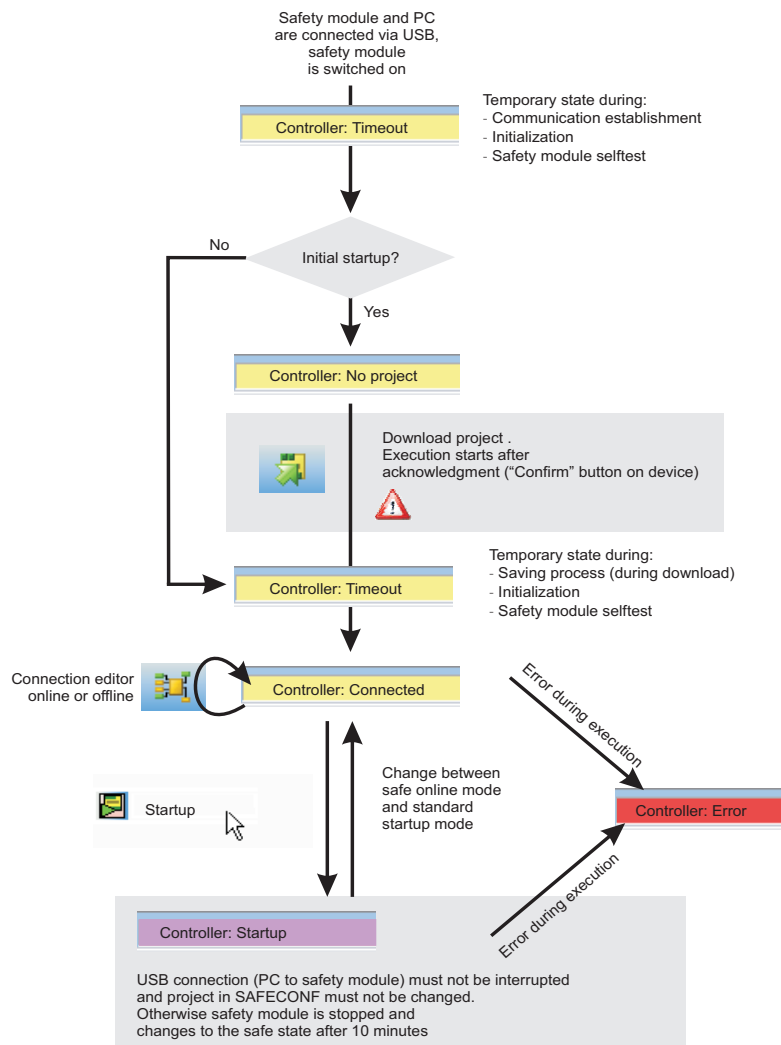

Figure 3-4 Possible operating modes (status) of PSR-TRISAFE-S/-M

3.3 Operating and indication elements

All operating and indication elements for the PSR-TRISAFE-S and PSR-TRISAFE-M safety modules are located on the front of the devices.

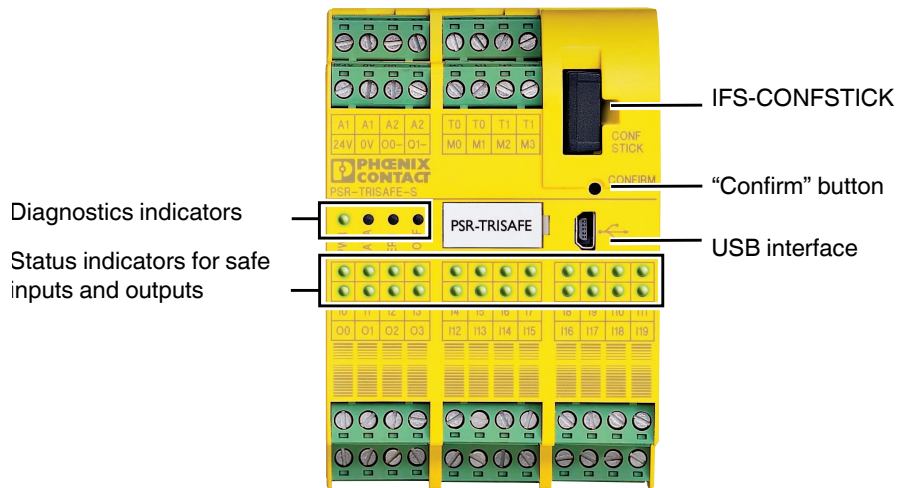

Figure 3-5 Operating and indication elements of PSR-TRISAFE-S/-M

3.3.1 Diagnostics and status indicators

Diagnostics indicators

The four diagnostics indicators on the front of the device show the operating status of the safety modules. The following LEDs are on the devices, from left to right:

Table 3-1 LED diagnostics indicators of the PSR-TRISAFE-S/-M

LED	Color	Description
PWR	Green	Indicator for the power supply of the safety module
DATA	Green	Only PSR-TRISAFE-M: Indicator for communication with extension modules via the PSR-TBUS. This LED only lights up when a PSR-TBUS device is connected.
ERR	Red	Error display / display for safety-critical system errors
CONF	Green	Indicator for the configuration status and communication via the USB interface / IFS-CONFSTICK

Status indicators

The state of each of the 20 safe digital inputs and four safe digital outputs is indicated by an LED each on the front of the device. The indicators match the signal actually present at the terminal blocks (not the process image).



For a detailed list of possible indicator combinations for diagnostic and status indicators, and their meanings, please refer to Section “Diagnostics” on page 93.

3.3.2 Confirm button

Confirming the new configuration

The “Confirm” button is located on the right-hand side of the front of the safety modules, above the USB interface. Press this button briefly using a pen to confirm a new configuration downloaded via the USB interface. The configuration is then accepted by the safety module.



See also “Downloading configuration from the SAFECONF configuration software” on page 84.

Resetting errors

With the “Confirm” button, you can reset the displayed errors. Depending on the type of error, the “Confirm” button has to be pressed briefly (3 s) or long (min. 15 s).

Reboot

Press the “Confirm” button on the device for the duration of at least 15 seconds to initiate a device restart. During the warm start, all outputs are initially set to the safe state. Active error messages are now reset, if the cause of the error is no longer present. The device then enters the initialization phase.

Replacing IFS-CONFSTICK

If you download a new configuration by replacing the IFS-CONFSTICK, press and hold the “Confirm” button while you remove and insert the IFS-CONFSTICK, as per the specified procedure.



For the exact procedure, go to Section “Downloading the configuration using the IFS-CONFSTICK memory module” on page 88.

3.3.3 USB interface



WARNING: Standard operation

The USB interface is not ESD protected. When there is a USB connection, the safety module is in standard operation mode. The safety function cannot be executed properly.

- Use the USB connection for startup only.
- Disconnect the USB connection for regulator operation.



NOTE: Electrostatic discharge

The safety modules contain components that can be damaged or destroyed by electrostatic discharge. When handling the USB interface, observe the necessary safety precautions against electrostatic discharge (ESD) in acc. with EN 61340-5-1 and IEC 61340-5-1.

The USB interface (standard USB 2.0) is used for communication between the safety module and the SAFECONF configuration software. The communication includes the following steps:

- Downloading configuration data (i.e., for the SAFECONF project)
- Optional: Uploading the configuration in order to open it as a project and edit it as required in SAFECONF
- Reading values from the safety module during operation and displaying them “live” in the connection editor of SAFECONF (online mode)
- Forcing of signals on the running safety module for startup purposes (standard startup mode)



Before connecting the safety module to the configuration PC, you have to install the SAFECONF configuration software with the appropriate USB drivers for the module.

Installing the USB driver:

The first time a PSR-TRISAFE safety module is connected to the configuration PC, the “Found New Hardware Wizard” appears. To install the driver, proceed as follows:

1. Answer the query “Can Windows connect to Windows Update to search for software?” with “No, not this time”.
2. Now follow the steps for installing the USB driver for PSR-TRISAFE: Confirm with “Next”.
 - a) When the “Would you like to install this device software?” query appears, trust the software manufacturer by clicking the “Install” button.
3. In the window for completing the hardware wizard, end the procedure by clicking the “Finish” button.

If the USB drivers have already been installed, the appropriately configured PC automatically detects the safety module once the USB connecting cable is connected.

If the SAFECONF configuration software has already been started, the software will detect the status of the safety module and display this in the status bar at the bottom right of the screen.

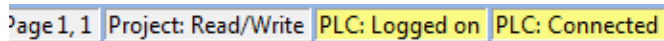

Figure 3-6 Status bar in the SAFECONF safe configuration software (safety module already contains a configuration project)

3.3.4 IFS-CONFSTICK

The safety modules are equipped with a pluggable IFS-CONFSTICK memory module.

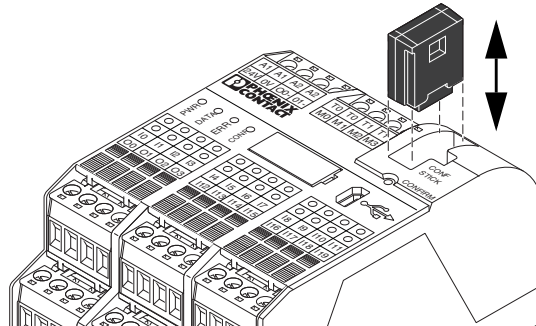

Figure 3-7 IFS-CONFSTICK with PSR-TRISAFE safety module

After the configuration has been downloaded from SAFECONF to the safety module, the configuration is saved in the IFS-CONFSTICK memory module.

The IFS-CONFSTICK **must** be inserted in the safety module both during normal operation and for downloading configuration data from SAFECONF via the USB interface.



As an alternative to downloading the configuration via the USB interface, you can also download it to the safety module using the IFS-CONFSTICK. See “Downloading the configuration using the IFS-CONFSTICK memory module” on page 88.

Behavior without IFS-CONFSTICK

If no IFS-CONFSTICK is inserted in the safety module or if it is removed, the safety module behaves as follows:

Table 3-2 Module behavior without IFS-CONFSTICK

Status of IFS-CONFSTICK	Module behavior
Stick is not inserted during configuration data download.	Configuration cannot be downloaded. SAFECONF outputs an error message.
Stick is not inserted when the safety module starts up.	All outputs stay disabled. Safety module indicates an error. The safety module does not execute any functions.
Stick is removed during operation.	Safety module disables all outputs and indicates an error. The safety module does not execute any functions any more.
To download the configuration, the stick is removed and inserted in acc. with the specifications. See “Downloading the configuration using the IFS-CONFSTICK memory module” on page 88	The safety module deactivates all outputs and does not execute any functions until the stick is inserted correctly again. Safety module does not indicate an error .

3.4 Signal connections

All input and output connections, with the exception of the USB interface, are made via plug-gable coded connection terminal blocks.

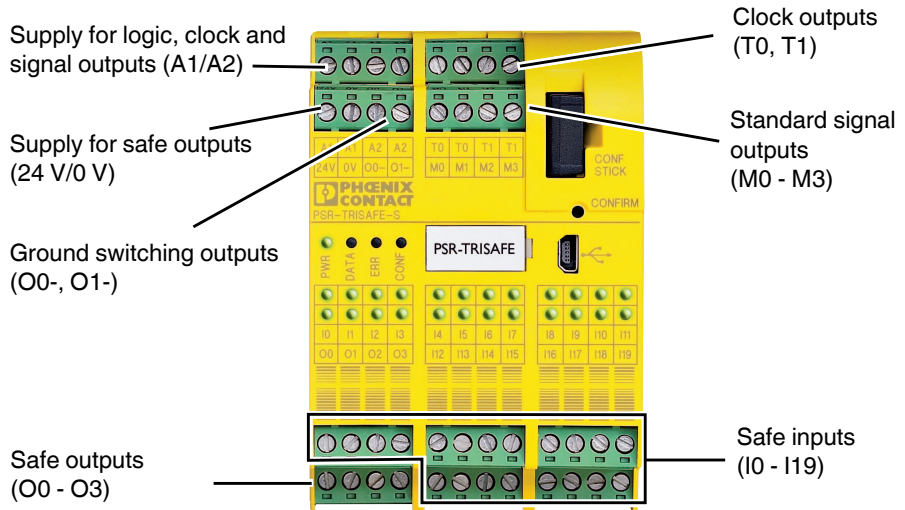

Figure 3-8 PSR-TRISAFE-S/-M signal connections

3.4.1 Safe inputs

I0 to I19

The 20 safe digital inputs I0 to I19 are used for direct connection of safe control devices or safety sensors.

The safe inputs are linked to the safety logic in the connection editor of the SAFECONF configuration software.



For more information on linking the safe inputs in the connection editor, refer to the Help system provided with the SAFECONF configuration software. There you can also find help on topics such as signal redundancy caused by dual signals, two-channel sensors, and cross-circuit detection.

3.4.2 Safe outputs

O0 to O3

Safety-related outputs O0 to O3 are designed as digital semiconductor outputs.



NOTE: Module damage

Inductive loads can destroy the outputs.

- Connect a suitable and effective protective circuit.
- Implement the protective circuit parallel to the load and not parallel to the switch contact.
- Prevent feedback at the outputs.

The outputs are controlled according to the configured safety logic.

The safe outputs are linked to the safety logic in the connection editor of the SAFECONF configuration software.



For more information on linking the safe outputs in the connection editor, refer to the Help system provided with the SAFECONF configuration software.

Increasing cross-circuit protection (optional)

To increase shutdown protection and cross-circuit protection, use outputs O0 and O1 in conjunction with ground switching outputs O0- and O1-. See Section “Ground switching outputs” on page 34.

Test pulses

The safe output signals are clocked with a test pulse.



Reduced availability due to test pulses

Test pulses can reduce the availability of the machine or system.

- Make sure that the connected load does not react to the test pulses.
- If necessary, use an appropriate filter terminal block.
See “Accessories” on page 126.



Test behavior at the ground switching output

The first dynamic test at the ground switching output occurs up to 60 s after the system restart. Therefore not all errors in the periphery or in the internal electronics of the outputs are detected the moment the switch-on occurs.

If the operating time of the ground switching outputs is < 60 s, the test is performed after a cumulated operating time of 60 s.

3.4.3 Signal outputs

M0 to M3

Non-safety-related signal outputs M0 to M3 are designed as digital semiconductor outputs.



NOTE: Module damage

Incorrect wiring can destroy the signal outputs.

- Do not connect the signal outputs in parallel.
- Prevent feedback at the signal outputs.

You can use the signal outputs to control a standard PLC or signaling units, for example.



Make sure that the GND potential of the signal receiver is the same as the GND potential of the safety module.

The signal outputs are linked in the connection editor of the SAFECONF configuration software.



For more information on linking the signal outputs in the connection editor, refer to the Help system provided with the SAFECONF configuration software.

3.4.4 Clock outputs

T0 and T1

The test clocks output at outputs T0 and T1 are used for cross-circuit detection at the inputs. Each output is available twice. The test clocks output at T0 and T1 are phase-shifted.

There is a fixed assignment between the clock outputs and the inputs. If this assignment is violated, the safety module detects a cross-circuit.

A cross-section can be detected between T0 and T1, as well as between a test clock and 24 V.

Between inputs with the same test clock, no cross-section is detected.

Cross-circuit detection in SAFECONF

To implement cross-circuit detection, configure the relevant safe inputs accordingly, using the parameterization editor in SAFECONF.

The SAFECONF configuration software specifies the clock signals to be used, as follows:

- For “even” inputs (I0, I2, I4 ... I18), cross-circuit detection is implemented with the test clock at T0.
- For “odd” inputs (I1, I3, I5 ... I19), cross-circuit detection is implemented with the test clock at T1.

To use cross-circuit detection for two-channel sensors, “even” inputs thus always have to be combined with “odd” inputs.



For additional information regarding configuration of cross-circuit detection over the clock outputs, refer to the Help system of the SAFECONF configuration system.

3.4.5 Ground switching outputs

O0- and O1-

Ground switching outputs O0- and O1- increase the shutdown protection and cross-circuit protection of the safety system. For example, with these outputs you can switch off a contactor connected to the safety module, both via the safe 24 V output and via ground.

The ground switching outputs are assigned to the safe outputs as follows and can only be used in the respective connection:

- Ground switching output O0- to output O0
- Ground switching output O1- to output O1



In order to use the ground switching outputs, you have to set the corresponding parameters for outputs O0 and O1 in the SAFECONF configuration software.
For more detailed information, please refer to the help topic “Parameterizing the inputs/outputs of the safety module”.

3.4.6 Supply connections



WARNING: Loss of safety function

The use of unsuitable power supplies and the incorrect connection of the power supply can result in the loss of the safety function.

- Power to connections A1/A2 and 24 V/0 V on the base device of a PSR-TRISAFE system should be supplied exclusively via the same supply voltage.
- Power to all other participating devices in the system should also be supplied exclusively via the same power supply.
- Only use power supply units with safe isolation and SELV / PELV in acc. with EN 50178 / VDE 0160.



WARNING: Loss of safety function due to interferences.

EMI can cause loss of the safety function.

- Connect the GND connection on the output side of the power supply unit to the functional earth ground (FE) of the system.



Connect both supply connections (A1/A2 and 24 V/0 V) for the safety module to work as intended.

24 V/0 V

The 24 V/0 V supply connection is used to supply the safe outputs of the safety module and the ground switching outputs with power.

A1/A2

Supply connection A1/A2 is used to supply the logic of the safety module and the clock and signal outputs with power.

Double terminal block contacts A1/A1 and A2/A2

The double terminal block contacts A1/A1 and A2/A2 are looped through and be used to supply additional modules or sensors.



NOTE: Module damage

A too high current load can permanently destroy the module.

- Pay attention to the max. permissible continuous current for devices connected to terminal blocks A1 and A2.

Limiting continuous current for looped-through current paths A1/A1 and A2/A2: see “Limiting continuous current” on page 107.

At the double terminal block contacts, 2- and 3-wire sensors and control devices can be supplied directly by the safety module ($U_N = 24 \text{ V DC}$).



WARNING: Loss of safety function due to parasitic voltages

For 3-wire sensors, please note that the GND potential of the sensor/control device is the same as the GND potential of the safety module.

4 PSR-TS-SDI8-SDIO4 safe extension module

4.1 Product description



Ensure compliance with the technical data of the safe extension module. See "Technical data of PSR-TS-SDI8-SDIO4" on page 113.

Extension module for PSR-TRISAFE-M

The PSR-TS-SDI8-SDIO4 safe extension module provides the PSR-TRISAFE-M safety module with additional configurable inputs and outputs. Depending on the configuration, the inputs and outputs are used to connect safe control units and sensors or actuators.

Safe digital inputs/outputs

The extension module features eight safe digital inputs.

You can configure four additional signals as either safe digital inputs or outputs. The signal direction (input or output) can only be switched over block by block, i.e., for all four signals at once.

The outputs are controlled depending on the safety logic executed in the PSR-TRISAFE-M safety module.

Digital clock/signal outputs (configurable)

The extension module has two digital clock/signal outputs that are configurable.

If you configure the outputs as clock outputs, they make cross-circuit detection possible at the inputs of the safe extension module.

If you configure the outputs as signal outputs, you can e.g. use them to control a standard PLC or signal units. The signal outputs are not safety-related.

Connection technology

The extension module is available either with screw connections or with spring-cage connections. All connection terminal blocks can be plugged in. The individual terminal block bases are mechanically coded to prevent confusion or connecting them the wrong way round.

Connection versions

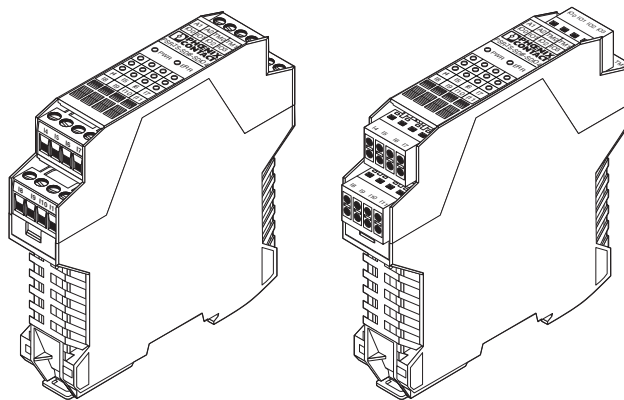

Figure 4-1 Screw terminal blocks (left) and spring-cage terminal blocks (right)

Block diagram

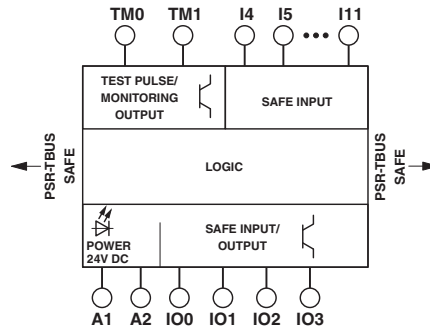

Figure 4-2 Block diagram for PSR-TS-SDI8-SDIO4

4.2 Diagnostics and status indicators

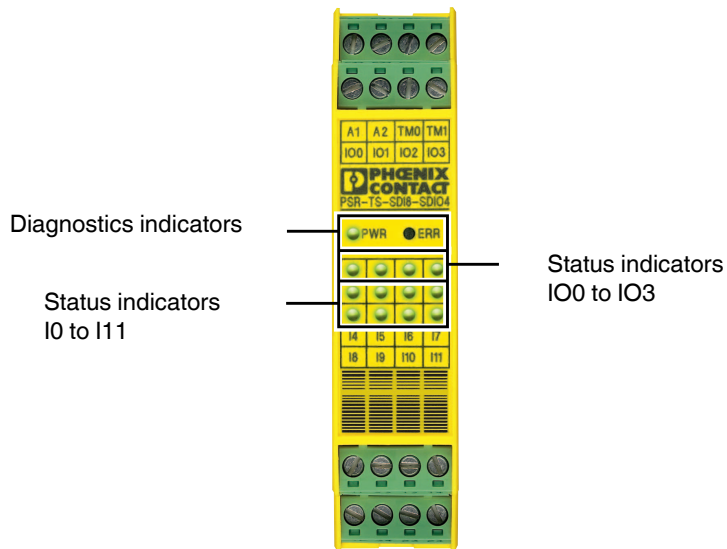

Figure 4-3 Diagnostics and status indicators PSR-TS-SDI8-SDIO4

Diagnostics indicators

The two diagnostics indicators on the front of the device show the operating status of the extension module.

Table 4-1 LED diagnostics indicators of the PSR-TS-SDI8-SDIO4

LED	Color	Description
PWR	Green	Indicator for the power supply of the extension module
ERR	Red	Error indication

Status indicators

The state of each of the eight safe inputs and the four configurable safe inputs/outputs is indicated by a separate LED each on the front of the device.



For a detailed list of possible indicator combinations for diagnostic and status indicators, and their meanings, please refer to Section “Diagnostics” on page 93.

4.3 Signal connections

All input and output connections are made via pluggable coded connection terminal blocks.

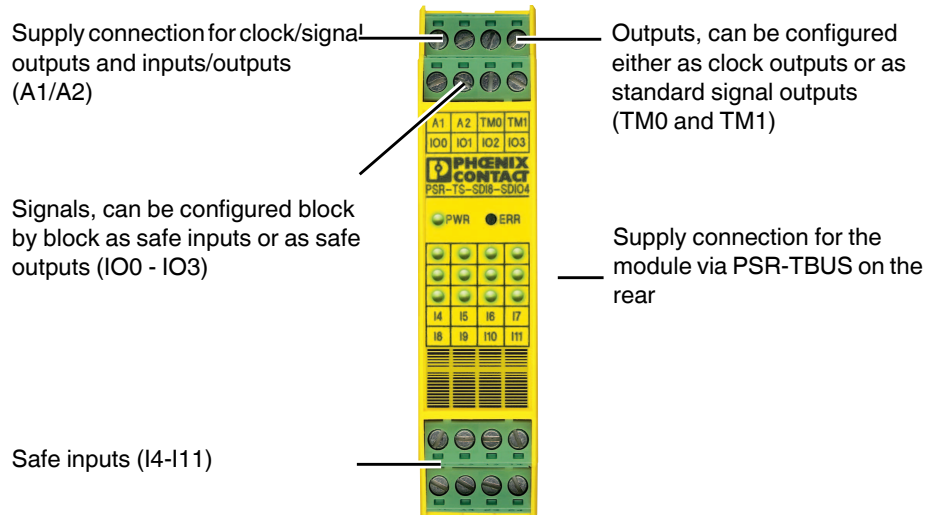

Figure 4-4 Signal connections of PSR-TS-SDI8-SDIO4

4.3.1 Safe inputs

The safe digital inputs are used for direct connection of safe control devices or safety sensors.

The safe extension module has eight safe digital inputs I4 to I11. An additional four safe digital inputs IO0 to IO3 result from appropriate parameterization and configuration.

The parameterization editor of the SAFECONF configuration software is used to parameterize and configure the input and output parameters. The safe inputs are linked to the safety logic in the connection editor of the configuration software.

The signal direction selected (input or output) for IO0 to IO3 can only be switched over block by block, i.e., for all four signals at once.

Prerequisites for IO0 to IO3 as inputs:

If you use the configurable IO0 to IO3 inputs/outputs as inputs, it is mandatory to implement cross-circuit detection by means of the extension module. To this end, power the respective inputs via clock outputs TM0 or TM1 of the extension module.

See also Section "Clock/signal outputs" on page 40.



For more information on parameterization and linking the safe inputs, refer to the help provided with the SAFECONF configuration software.

There you can also find help on topics for the safe inputs, such as signal redundancy caused by dual signals, two-channel sensors and cross-circuit detection.

**I4 to I11
IO0 to IO3 as inputs**

4.3.2 Safe outputs

IO0 to IO3 as outputs

Signals IO0 to IO3 can be configured as safety-related outputs and as digital semiconductor outputs.



NOTE: Module damage

Inductive loads can destroy the outputs.

- Connect a suitable and effective protective circuit.
- Implement the protective circuit parallel to the load and not parallel to the switch contact.
- Prevent feedback at the outputs.

The outputs are controlled depending on the safety logic executed in the PSR-TRISAFE-M safety module.

The safe outputs are linked to the safety logic in the connection editor of the SAFECONF configuration software.



For more information on parameterization and linking the safe outputs, refer to the help provided with the SAFECONF configuration software.

Test pulses

The safe output signals are clocked with a test pulse.



Reduced availability due to test pulses

Test pulses can reduce the availability of the machine or system.

- Make sure that the connected load does not react to the test pulses.
- If necessary, use an appropriate filter terminal block.
See "Accessories" on page 126.

4.3.3 Clock/signal outputs

TM0 and TM1

You can configure outputs TM0 and TM1 of the extension module either as non-safety-related digital signal outputs or as safe clock outputs.

The parameterization editor of the SAFECONF configuration software is used to parameterize and configure the output parameters.



For more information on parameterization and linking the clock/signal outputs in the parameterization editor, refer to the help provided with the SAFECONF configuration software.

TM0 and TM1 as signal outputs

If you configure outputs TM0 and TM1 as signal outputs, you can e.g. use them to control a standard PLC or signal units.



Make sure that the GND potential of the signal receiver is the same as the GND potential of the safety module.

The non-safety-related signal outputs are designed as digital semiconductor outputs.

**NOTE: Module damage**

Incorrect wiring can destroy the signal outputs.

- Do not connect the signal outputs in parallel.
- Prevent feedback at the signal outputs.

Configure the two outputs TM0 and TM1 as signal outputs by configuring the following settings in the parameterization editor in SAFECNF. The signal outputs can only be configured jointly.

- For TM0 to TM1, set the “Configuration” parameter to the value “Signaling output - M0 to M1”.

The signal outputs are linked in the connection editor of the SAFECNF configuration software.



For more information on linking the signal outputs in the connection editor, refer to the Help system provided with the SAFECNF configuration software.

TM0 and TM1 as clock outputs

If you configure outputs TM0 and TM1 as clock outputs, they make cross-circuit detection possible at the inputs of the safe extension module.
See Section “Error detection” on page 21.

If you use the configurable IO0 to IO3 inputs/outputs as inputs, it is mandatory to implement cross-circuit detection by means of the extension module, i.e. power must be supplied to the inputs concerned via clock outputs TM0 or TM1 of the extension module.
See Section “Safe inputs” on page 39.



If you use the configurable input/outputs IO0 to IO3 as outputs, configuring TM0 and TM1 as clock outputs generates an error.

Configure the two outputs TM0 or TM1 as clock outputs by configuring the following settings in the safe parameterization editor. The clock outputs can only be configured jointly.

- For IO0 to IO3, set the “Signal configuration” parameter to “Configured as safe inputs with test pulse”
- For TM0 to TM1, set the “Configuration” parameter to the value “Test pulse T0 to T1”.

The test clocks output at outputs TM0 and TM1 (if configured accordingly) are used for cross-circuit detection at the inputs of the extension module. The test clocks output at T0 and T1 are phase-shifted with regard to each other.

To implement cross-circuit detection, you have to configure the relevant safe inputs accordingly, using the parameterization editor in SAFECNF.

The SAFECNF configuration software specifies the clock signals to be used, as follows:

- For “even” inputs (IO0 and IO2 and I4 ... I10), cross-circuit detection is implemented with the test clock at TM0.
- For “odd” inputs (IO1 and IO3, as well as I5 ... I11), cross-circuit detection is implemented with the test clock at TM1.

4.3.4 Supply connections



WARNING: Loss of safety function

The use of unsuitable power supplies and the incorrect connection of the power supply can result in the loss of the safety function.

- Power to connections A1/A2 and 24 V/0 V on the base device of a PSR-TRISAFE system should be supplied exclusively via the same supply voltage.
- Power to all other participating devices in the system should also be supplied exclusively via the same power supply.
- Only use power supply units with safe isolation and SELV / PELV in acc. with EN 50178 / VDE 0160.



WARNING: Loss of safety function due to interferences.

EMI can cause loss of the safety function.

- Connect the GND connection on the output side of the power supply unit to the functional earth ground (FE) of the system.



Connect both supply connections (A1/A2 and PSR-TBUS) for the safe extension module to work as intended.

Yellow PSR-TBUS

The logic of the PSR-TS-SDI8-SDIO4 safe extension module is supplied with power via the yellow PSR-TBUS DIN rail connector.



NOTE: Module damage

Using an incorrect DIN rail connector or a dummy plug can cause the module to become faulty.

- Use only the yellow PSR-TBUS DIN rail connector.
- **Never** use the green TBUS DIN rail connector.
- **Never** use the PSR-TBUS-TP dummy plug.

A1/A2

Supply connection A1/A2 is used to supply the parameterizable inputs/outputs and the parameterizable clock/signal outputs with power.

5 PSR-TS-SDOR4 safe extension module

5.1 Product description



Ensure compliance with the technical data of the safe extension module, see “Technical data of PSR-TS-SDOR4” on page 118.

Extension module for PSR-TRISAFE-M

The PSR-TS-SDOR4 safe extension module provides the PSR-TRISAFE-M safety module with additional relay outputs, to which you can connect actuators.

Safe relay outputs

The extension module has four safe relay outputs. The relay outputs are controlled depending on the safety logic executed in the PSR-TRISAFE-M safety module.

Digital signal outputs

The extension module has four non-safety-related digital signal outputs. You can use the signal outputs to control a standard PLC or signaling units, for example.

Connection technology

The extension module is available either with screw connections or with spring-cage connections. All connection terminal blocks can be plugged in. The individual terminal block bases are mechanically coded to prevent confusion or connecting them the wrong way round.

Connection versions

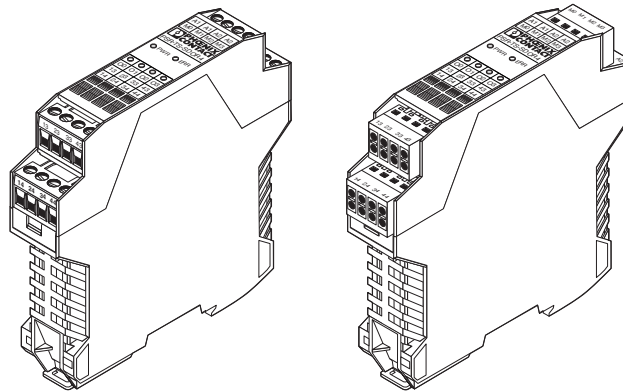

Figure 5-1 Screw terminal blocks (left) and spring-cage terminal blocks (right)

Block diagram

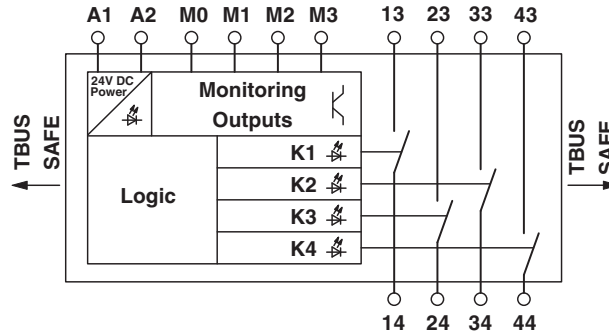

Figure 5-2 Block diagram for PSR-TS-SDOR4

Insulation coordination

The following table shows the insulation of the relay outputs between each other and to the logic area of the device.

Table 5-1 Insulation coordination

	A1A2 24 V/0 V	13/14	23/24	33/34	43/44
A1A2 24 V/0 V	-	6 kV ST	6 kV ST	6 kV ST	6 kV ST
13/14	-	-	4 kV BI	4 kV BI	4 kV BI
23/24	-	-	-	4 kV BI	4 kV BI
33/34	-	-	-	-	4 kV BI
43/44	-	-	-	-	-

Key:

- BI** Basic insulation
- ST** Safe isolation



Basic insulation
 (rated surge voltage: 4 kV)
 A mixture of SELV and PELV is strictly prohibited.

Safe isolation / Reinforced insulation
 (rated surge voltage: 6 kV)
 Reinforced insulation (e.g., thanks to greater air clearances and creepage distances between conductive paths) is designed for one overvoltage category higher than basic insulation. This means that SELV circuits of $U \leq 25 \text{ V AC}$ or $U \leq 60 \text{ V DC}$ and circuits with higher voltages can be mixed.

5.2 Diagnostics and status indicators

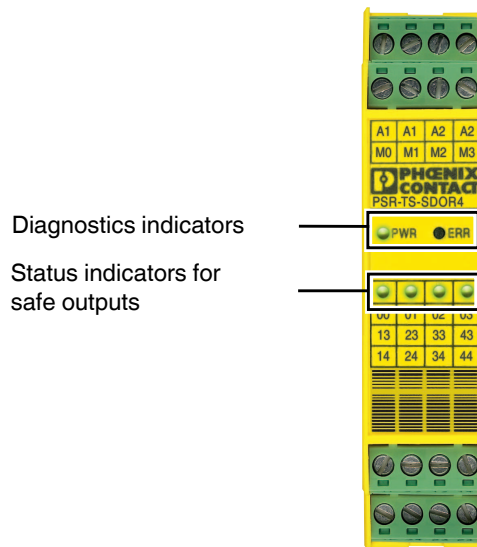

Figure 5-3 Diagnostics and status indicators PSR-TS-SDOR4

Diagnostics indicators

The two diagnostics indicators on the front of the device show the operating status of the extension module.

Table 5-2 LED diagnostics indicators of the PSR-TS-SDOR4

LED	Color	Description
PWR	Green	Indicator for the power supply of the extension module
ERR	Red	Error indication

Status indicators

The state of each of the four safe relay outputs is indicated by an LED each on the front of the device.



For a detailed list of possible indicator combinations for diagnostic and status indicators, and their meanings, please refer to Section “Diagnostics” on page 93.

5.3 Signal connections

All output connections are made via pluggable coded connection terminal blocks.

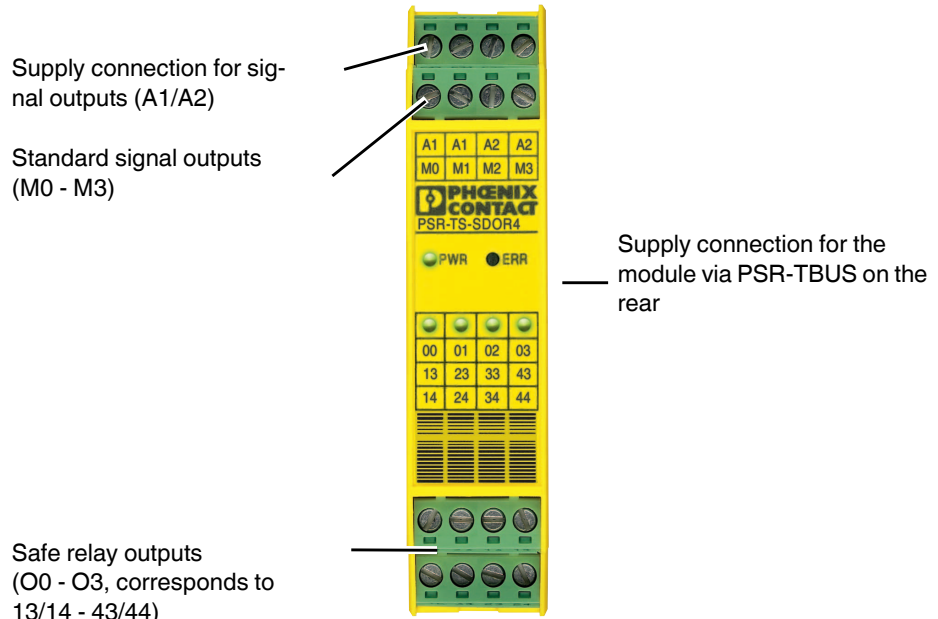

Figure 5-4 Signal connections of PSR-TS-SDOR4

5.3.1 Safe relay outputs

O0 to O3

Outputs O0 to O3 are configured as safety-related relay outputs.

Table 5-3 Relay outputs

Output	Relay contacts	Output	Relay contacts
O0	13/14	O2	33/34
O1	23/24	O3	43/44



WARNING: Loss of safety function / Hazardous shock currents

Mixing different voltages (e.g. SELV/PELV with mains voltage) can destroy the relay contacts. The safety function can be lost and dangerous shock currents can occur.

- Please observe the information in table 5-1 „Insulation coordination“ on page 44.



NOTE: Module damage

Inductive loads can destroy the outputs.

- Connect a suitable and effective protective circuit.
- Implement the protective circuit parallel to the load and not parallel to the switch contact.
- Prevent feedback at the outputs.

You can use the relay outputs as follows:

- Single-channel assignment
- Two-channel assignment

The table below provides more detailed information on the assignment.

Table 5-4 Assignment of relay outputs

Assignment	Number of outputs	Comment
Two-channel	2 two-channel relay outputs (connected in pairs) Pair 1: 13/14 and 23/24 (bridge between contacts 13/23) Pair 2: 33/34 and 43/44 (bridge between contacts 33/43)	Prerequisite: The bridges between the 13/23 und 33/43 contacts are plugged in and the parameterization has been done accordingly. Info: In the delivery state, the relay outputs are connected in pairs.
Single-channel	4 single-channel relay outputs - 13/14 - 23/24 - 33/34 - 43/44	Prerequisite: The bridges between the 13/23 und 33/43 contacts have been removed and the parameterization has been done accordingly.



Note for Cat. 4 applications:

To achieve Cat. 4 in acc. with EN ISO 13849-1, use the paired connection of the relay outputs (two-channel assignment).

The relay outputs are controlled depending on the safety logic executed in the PSR-TRISAFE-M safety module.

The safe relay outputs are linked to the safety logic in the connection editor of the SAFECNF configuration software.



For more information on parameterization and linking the safe outputs, refer to the help provided with the SAFECNF configuration software.

5.3.2 Signal outputs

M0 to M3

Non-safety-related signal outputs M0 to M3 are designed as digital semiconductor outputs.



NOTE: Module damage

Incorrect wiring can destroy the signal outputs.

- Do not connect the signal outputs in parallel.
- Prevent feedback at the signal outputs.

You can use the signal outputs to control a standard PLC or signaling units, for example.



Make sure that the GND potential of the signal receiver is the same as the GND potential of the safety module.

The signal outputs are linked in the connection editor of the SAFECONF configuration software.



For more information on linking the signal outputs in the connection editor, refer to the Help system provided with the SAFECONF configuration software.

5.3.3 Supply connections



WARNING: Loss of safety function

The use of unsuitable power supplies and the incorrect connection of the power supply can result in the loss of the safety function.

- Power to connections A1/A2 and 24 V/0 V on the base device of a PSR-TRISAFE system should be supplied exclusively via the same supply voltage.
- Power to all other participating devices in the system should also be supplied exclusively via the same supply voltage.
- Only use power supply units with safe isolation and SELV / PELV in acc. with EN 50178 / VDE 0160.



Connect both supply connections (A1/A2 and PSR-TBUS) for the safe extension module to work as intended.

Yellow PSR-TBUS

The logic of the PSR-TS-SDOR4 safe extension module is supplied with power via the yellow PSR-TBUS DIN rail connector.



NOTE: Module damage

Using an incorrect DIN rail connector or a dummy plug can cause the module to become faulty.

- Use only the yellow PSR-TBUS DIN rail connector.
- **Never** use the green TBUS DIN rail connector.
- **Never** use the PSR-TBUS-TP dummy plug.

A1/A2

Supply connection A1/A2 is used to supply the signal outputs of the safe extension module.

Double terminal block contacts A1/A1 and A2/A2

The double terminal block contacts A1/A1 and A2/A2 are looped through and be used to supply additional modules or sensors.

**NOTE: Module damage**

A too high current load can permanently destroy the module.

- Pay attention to the max. permissible continuous current for devices connected to terminal blocks A1 and A2.

Limiting continuous current for looped-through current paths A1/A1 and A2/A2: see "Limiting continuous current" on page 107.

At the double terminal block contacts, 2- and 3-wire sensors and control devices can be supplied directly by the safety module ($U_N = 24 \text{ V DC}$).

**WARNING: Loss of safety function due to parasitic voltages**

For 3-wire sensors, please note that the GND potential of the sensor/control device is the same as the GND potential of the safety module.

6 Wiring examples

6.1 Notes on the wiring examples

In the following examples, clock outputs T0 and T1 are used.

On the PSR-TS-SDI8-SDIO4 safe extension module, they correspond to clock outputs TM0 and TM1, if these have been configured as clock outputs.

Terminal blocks IO0 to IO3 of the PSR-TS-SDI8-SDIO4 safe extension module act as inputs if they have been configured as inputs accordingly.

6.2 Single-channel assignment of safe digital inputs

For the single-channel assignment of safe digital inputs, the inputs operate independently of one another.

6.2.1 Cross-circuit monitoring enabled

If an input pair is parameterized as single-channel with cross-circuit monitoring, the fixed assignment is as follows:

- All “even” inputs I0, I2, ... are permanently assigned to clock output T0.
- All “odd” inputs I1, I3, ... are permanently assigned to clock output T1.

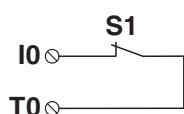

Key:

- S1** Safety switch
- I0** Input
- T0** Clock output

Figure 6-1 Single-channel assignment of inputs

Basic specifications

Sensor	Single-channel
Sensor supply	Internally through clock output T0 (clocked) or T1 (clocked)
Achievable safety integrity	SIL 1/SILCL 1/Cat. 1/PL c

Typical parameterization

Parameterization	Parameterized as
Input xx channel 1/channel 2	
Cross-circuit monitoring	Yes, with test clock T0 for all “even” inputs I0, I2, ... Yes, with test clock T1 for all “odd” inputs I1, I3, ...

6.2.2 Cross-circuit monitoring disabled, external supply

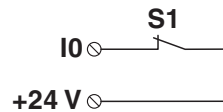

Key:

- S1** Safety switch
- I0** Input
- +24 V** Supply by external 24 V (observe potential reference)

Figure 6-2 Single-channel assignment of inputs: external supply

Basic specifications

Sensor	Single-channel switch
Sensor supply	External (24 V, observe potential reference)
Achievable safety integrity	SIL 1/SILCL 1/Cat. 1/PL c



WARNING: Loss of safety function

Cross-circuits can result in the loss of the safety function.

- Prevent cross-circuits in order to achieve the specified safety integrity.

Typical parameterization

Parameterization	Parameterized as
Input xx channel 1/channel 2	
Cross-circuit monitoring	No

6.2.3 External supply (OSSD)

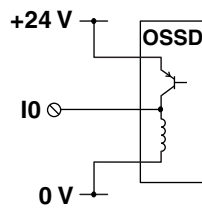

Key:

- OSSD** OSSD sensor
- I0** Input
- +24 V** Supply through external 24 V
- 0 V** External 0 V
(observe potential reference)

Figure 6-3 Single-channel assignment of inputs: external supply (OSSD)



WARNING: Loss of safety function

Parasitic voltages can result in the loss of the safety function.

- Prevent parasitic voltage by using appropriate wiring.

Basic specifications

Sensor	Single-channel OSSD output (with internal testing)
Sensor supply	External (OSSD sensor)
Achievable safety integrity	SIL 1/SILCL 1/Cat. 1/PL c



WARNING: Loss of safety function

Cross-circuits can result in the loss of the safety function.

- Prevent cross-circuits in order to achieve the specified safety integrity.

Typical parameterization

Parameterization	Parameterized as
Input xx channel 1/channel 2	
Cross-circuit monitoring	No

6.3 Two-channel equivalent assignment of safe digital inputs

For two-channel assignment of the inputs, two adjacent inputs of the same male connector are used.



For the two-channel equivalent assignment, use the inputs of the “Equivalent” function block in the SAFECONF configuration software.
 You can find the function description of this block in the help of the software.

6.3.1 Cross-circuit monitoring enabled, supply through T0 and T1

Possible wiring versions:

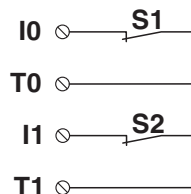

Key:

S1, S2 Switching elements

I0, I1 Inputs

T0, T1 Supply through T0 **and** T1

Figure 6-4 Two-channel equivalent assignment of inputs, supply through T0 and T1 (both clocked)

Basic specifications

Sensor	Two-channel equivalent with cross-circuit monitoring
Sensor supply	Internally through clock output T0 and T1 (both clocked)
Achievable safety integrity	SIL 3/SILCL 3/Cat. 4/PL e

Typical parameterization

Parameterization	Parameterized as
Input xx channel 1/channel 2	
Cross-circuit monitoring	Yes, with test clock T0 at I0 Yes, with test clock T1 at I1

6.3.2 Cross-circuit monitoring disabled, external supply

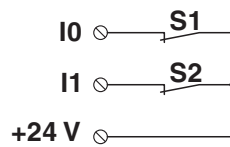

Key:

S1, S2 Switching elements

I0, I1 Inputs

+24 V Supply by external 24 V (observe potential reference)

Figure 6-5 Two-channel equivalent assignment of inputs, external supply, cross-circuit monitoring disabled

Basic specifications

Sensor	Two-channel equivalent
Sensor supply	External (24 V, observe potential reference)
Achievable safety integrity	SIL 3/SILCL 3/Cat. 3/PL d



WARNING: Loss of safety function

An accumulation of errors can result in the loss of the safety function.

- Test the safety function at regular intervals to detect errors at an early stage.

Typical parameterization

Parameterization	Parameterized as
Input xx channel 1/channel 2	
Cross-circuit monitoring	No

6.3.3 External supply (OSSD)

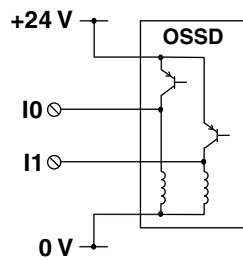

- Key:**
- OSSD** OSSD sensor
 - I0, I1** Inputs
 - +24 V** Supply through external 24 V
 - 0 V** External 0 V (observe potential reference)

Figure 6-6 Two-channel equivalent assignment of inputs, external supply (OSSD)



WARNING: Loss of safety function
 Parasitic voltages can result in the loss of the safety function.

- Prevent parasitic voltage by using appropriate wiring.

Basic specifications

Sensor	Two-channel OSSD output (with internal testing)
Sensor supply	External (OSSD sensor)
Achievable safety integrity	SIL 3/SILCL 3/Cat. 4/PL e

Typical parameterization

Parameterization	Parameterized as
Input xx channel 1/channel 2	
Cross-circuit monitoring	No

6.4 Two-channel non-equivalent assignment of safe digital inputs

For two-channel assignment of the inputs, two adjacent inputs of the same male connector are used.



For the two-channel non-equivalent assignment, use the inputs of the “Antivalent” function block in the SAFECONF configuration software.

You can find the function description of this block in the help of the software.

6.4.1 Cross-circuit monitoring enabled, supply through T0 and T1

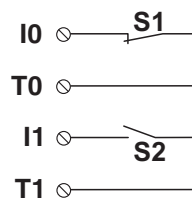

Key:

S1, S2 Switching elements

I0, I1 Inputs

T0, T1 Supply through T0 **and** T1

Figure 6-7 Two-channel non-equivalent assignment of inputs, supply through T0 and T1, cross-circuit monitoring enabled

Basic specifications

Sensor	Two-channel non-equivalent
Sensor supply	Internally through clock output T0 and T1, cross-circuit monitoring enabled
Achievable safety integrity	SIL 3/SILCL 3/Cat. 4/PL e



WARNING: Loss of safety function

An accumulation of errors can result in the loss of the safety function.

- Test the safety function at regular intervals to detect errors at an early stage.

Typical parameterization

Parameterization	Parameterized as
Input xx channel 1/channel 2	
Cross-circuit monitoring	Yes, with test clock T0 at I0 Yes, with test clock T1 at I1

6.4.2 Cross-circuit monitoring disabled, external supply

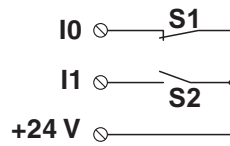

Key:

S1, S2 Switching elements

I0, I1 Inputs

+24 V Supply by external 24 V (observe potential reference)

Figure 6-8 Two-channel non-equivalent assignment of inputs, external supply

Basic specifications

Sensor	Two-channel non-equivalent
Sensor supply	External (24 V, observe potential reference)
Achievable safety integrity	SIL 3/SILCL 3/Cat. 3/PL d



WARNING: Loss of safety function

An accumulation of errors can result in the loss of the safety function.

- Test the safety function at regular intervals to detect errors at an early stage.

Typical parameterization

Parameterization	Parameterized as
Input xx channel 1/channel 2	
Cross-circuit monitoring	No

6.5 Safe digital outputs

6.5.1 Notes on the protective circuit for external relays/contactors (freewheeling circuit)

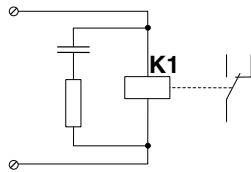

Figure 6-9 Example of the freewheeling circuit for an external relay

Observe the following measures:

- Limit the voltage induced on circuit interruption to < -15 V (e.g., with RC elements, suppressor diodes or varistors).
- Please note that the freewheeling circuit affects the fall time and the service life of the contactor.
- Please observe the specifications of the relay manufacturer when sizing the relay protective circuit.

6.5.2 Single-channel assignment of safe digital outputs

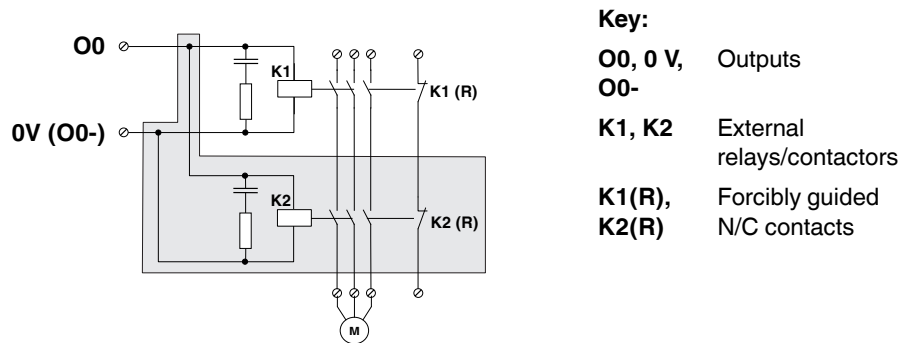

Figure 6-10 Single-channel assignment of outputs

K1 (R) and K2 (R) represent the force-guided N/C contacts for monitoring the state of the relay (readback contacts).

- Connect these contacts via safe digital inputs.
- Evaluate the readback and therefore the state of the switching elements in the safe application program.



WARNING: Loss of safety function

Parasitic voltages can result in the loss of the safety function.

- Prevent parasitic voltage by using appropriate wiring.

Basic specifications

Actuator	Single-channel	Two-channel
Achievable safety integrity	SIL 1/SILCL 1/Cat. 1/PL c	SIL 3/SILCL 3/Cat. 4/PL e

6.5.3 Two-channel assignment of safe digital outputs

For two-channel assignment of the safe outputs, two adjacent outputs of the same male connector are used. This assignment cannot be parameterized.

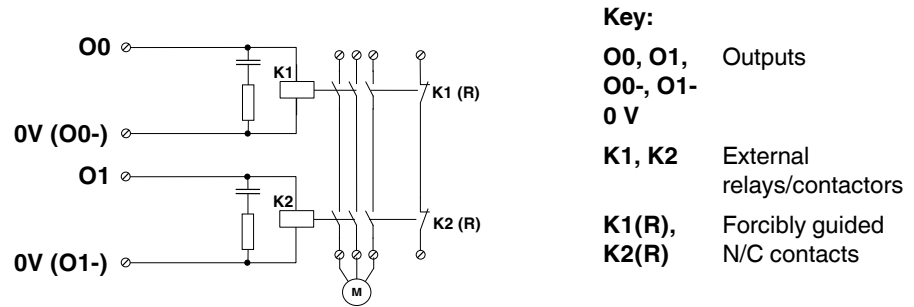

Figure 6-11 Two-channel assignment of outputs

K1 (R) and K2 (R) represent the force-guided N/C contacts for monitoring the state of the relay (readback contacts).

- Connect these contacts via safe digital inputs.
- Evaluate the readback and therefore the state of the switching elements in the safe application program.



WARNING: Loss of safety function

Parasitic voltages can result in the loss of the safety function.

- Prevent parasitic voltage by using appropriate wiring.

Basic specifications

Actuator	Two-channel
Achievable safety integrity	SIL 3/SIL CL 3/Cat. 4/PL e

6.6 Safe relay outputs

6.6.1 Notes on the protective circuit for external relays/contactors (freewheeling circuit)

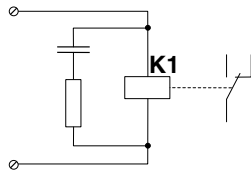

Figure 6-12 Example of the freewheeling circuit for an external relay

A protective circuit via the relay contacts is not permitted.

6.6.2 Single-channel assignment of safe relay outputs

For single-channel assignment, the safety relays operate independently of one another. They are controlled individually.

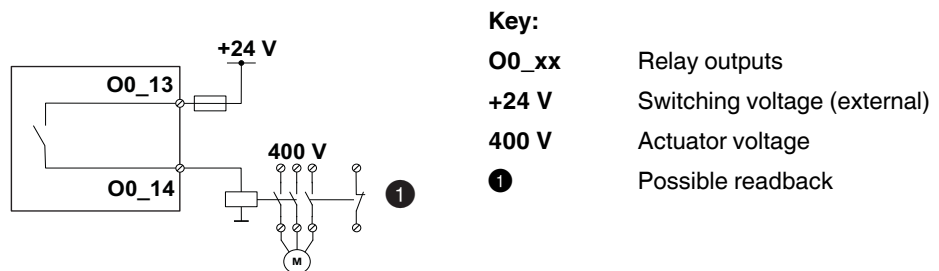

Figure 6-13 Single-channel assignment of relay outputs



Optional readback of the actuator is possible via the safe inputs of the PSR-TRISAFE system.



Information on switching other voltages: see Section 14.3, “Technical data of PSR-TS-SDOR4”.

Basic specifications

Actuator	Single-channel
Achievable safety integrity	SILCL 1/Cat. 1/PL c

Typical parameterization

Parameterization	Parameterized as
Signal configuration	Single-channel (O0 and O1 switching independently)

6.6.3 Two-channel assignment of safe relay outputs

For two-channel assignment, the safety relays for both channels operate together. This assignment is fixed and cannot be parameterized.

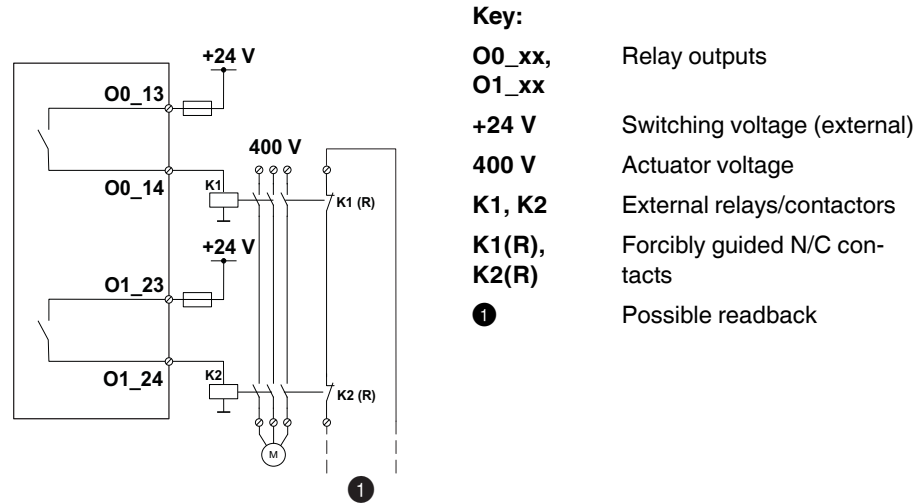

Figure 6-14 Two-channel assignment of relay outputs



Potential readback of the actuator is possible via the safe inputs of the PSR-TRISAFE system.



Information on switching other voltages: see Section 14.3, "Technical data of PSR-TS-SDOR4".

7 Assembly, removal, and electrical installation

7.1 Safety notes on assembly, removal and electrical installation

Qualified personnel

Assembly, removal, and electrical installation of the PSR-TRISAFE system may only be performed by qualified personnel.
See “Qualified personnel” on page 9.

**WARNING: Serious personal injury or damage to equipment**

Disregarding this warning may result in damage to equipment and/or serious personal injury.

**WARNING: Hazardous voltage**

If the power to the system is not disconnected before assembly, removal and electrical installation work is carried out, dangerous electric shocks could result.

- Only perform assembly, removal and electrical installation of the safety modules and safe extension modules when the power supply is disconnected.
- Prior to installation work, disconnect the power to the entire system and make sure that it cannot be switched on again unintentionally.
- Make sure all work is completed before switching the power back on and that the system does not pose a hazard.

**WARNING: Unintentional machine startup**

If the power to the system is not disconnected before assembly, removal and electrical installation work is carried out, the machine could unintentionally start up.

- Only perform assembly, removal and electrical installation of the safety modules and safe extension modules when the power supply is disconnected.
- Prior to installation work, disconnect the power to the entire system and make sure that it cannot be switched on again unintentionally.
- Make sure all work is completed before switching the power back on and that the system does not pose a hazard.

**NOTE: Electrostatic discharge**

The modules contain components that can be damaged or destroyed by electrostatic discharge. When handling the modules, observe the necessary safety precautions against electrostatic discharge (ESD) in acc. with EN 61340-5-1 and IEC 61340-5-1.

7.2 Assembly

7.2.1 Assembly instructions



NOTE: Damage to equipment

Incorrect installation could cause material damage.

- Please observe the following notes for installing the PSR-TRISAFE system:

Table 7-1 Important assembly instructions

Connection via DIN rail connector	
PSR-TBUS	Only use the yellow PSR-TBUS DIN rail connector to connect the PSR-TRISAFE-S and PSR-TRISAFE-M safety modules, as well as the PSR-TS-SDI8-SDIO4 and PSR-TS-SDOR4 safe extension modules. Connection with another DIN rail connector is not permitted.
TBUS	Use only the green TBUSDIN rail connector to connect standard extension devices (gateways). Connection with another DIN rail connector is not permitted.
No dummy plug PSR-TBUS-TP	Do not use dummy plugs (PSR-TBUS-TP - 292981716) for the PSR-TBUS and TBUS DIN rail connector, as this could destroy the device.
Mounting direction for extensions	
Standard extension: left	Mount a standard extension device (gateway) to the left of the PSR-TRISAFE-S or PSR-TRISAFE-M safety module.
Safe extension: right	Mount the safe extension modules PSR-TS-SDI8-SDIO4 and/or PSR-TS-SDOR4 to the right of safety module PSR-TRISAFE-M.
Maximum number of extension devices	
Standard extension	Connect max. one standard extension device (gateway) to the safety module PSR-TRISAFE-S or PSR-TRISAFE-M. Other standard bus devices are possible. For more information, refer to the user documentation of the gateway used.
Safe extension	Connect max. ten safe extension modules to the PSR-TRISAFE-M safety module.



You can find a visual representation of a PSR-TRISAFE system extended with PSR-TBUS and TBUS in Figure 2-2 on page 17.

7.2.2 Mounting location

- Mount the module in a control cabinet or junction box protected from dust and humidity (IP54 or higher).
- Secure the control cabinet/junction box to prevent unauthorized opening.

7.2.3 Mounting work

35 mm DIN rail

The modules of the PSR-TRISAFE system are designed exclusively for mounting on 35 mm DIN rails in accordance with EN 60715. To avoid contact resistance, only use clean, corrosion-free DIN rails.

DIN rail connector TBUS / PSR-TBUS (optional)

1. **Optional:** If you want to use the DIN rail connectors to create a connection station with extension units, proceed as follows:
 - b) Connect together the required number of DIN rail connectors for the connection station (see figure 7-1, step A).
 - c) Push the connected DIN rail connectors onto the DIN rail (see steps B and C).

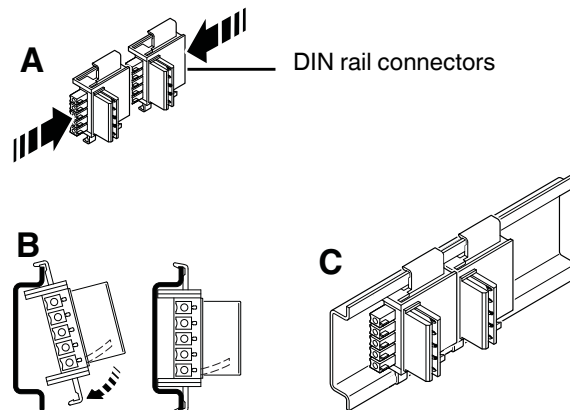

Figure 7-1 Mounting DIN rail connectors

Mounting the PSR-TRISAFE module

2. Place the module onto the DIN rail from above, so that the upper holding keyway of the module hooks onto the top edge of the DIN rail (see figure 7-2).



NOTE: Module damage

Using an incorrect DIN rail connector or a dummy plug can cause the module to become faulty.

- Only use the yellow PSR-TBUS DIN rail connector for safe extension modules.
- For standard extension devices, use the green TBUS DIN rail connector.
- **Never** use the PSR-TBUS-TP dummy plug.



NOTE: Damage to the connectors

When using DIN rail connectors, make sure that the contact opening in the base of the module is aligned correctly over the contact block of the DIN rail connector.



NOTE: Wear on the connectors

Up to eight mating cycles are permitted for connecting the modules by means of the DIN rail connector.

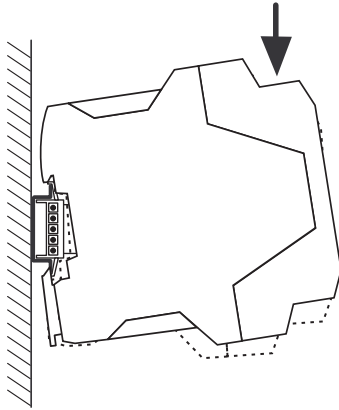

Figure 7-2 Snapping a PSR-TRISAFE module onto the DIN rail

3. Push the lower part of the module that is furthest from the DIN rail towards the DIN rail until it audibly snaps in.
4. Check that the module is securely mounted on the DIN rail.
5. When mounting additional modules on the DIN rail (e.g., gateways or power supplies), place them on the DIN rail with no spacing, i.e., in direct contact with the sides of the housing.
6. On both sides of the module or module group, mount a CLIPFIX end bracket. This prevents the modules from slipping and incorrectly connecting to the other modules on the DIN rail. Additionally you can thus avoid accidental attaching of additional DIN rail connectors.

7.3 Dismantling

1. Pull the locking latch on the bottom of the module down using a screwdriver, for example, to release the module from the DIN rail.
2. Lift the bottom of the module away from the DIN rail slightly.
3. Pull the module diagonally upwards away from the DIN rail.

7.4 Electrical installation

For reliable and shockproof contacts, strip the connecting ends for all modules of the PSR-TRISAFE system as follows:

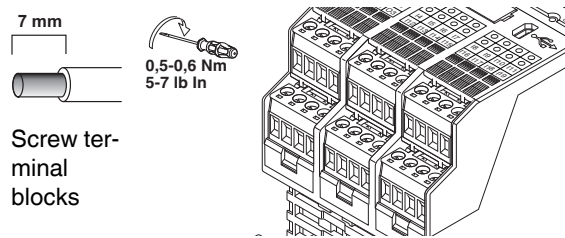

Figure 7-3 Connection to screw terminal blocks

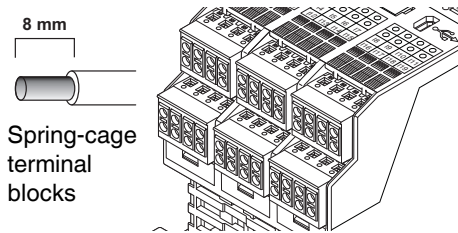

Figure 7-4 Connection to spring-cage terminal blocks



It is recommended that ferrules are used to connect stranded cables.



In order to comply with UL approval, use copper cables that are designed for operating temperatures $> 75\text{ }^{\circ}\text{C}$.

7.4.1 Connecting signal lines

Observing manufacturer's information

Connect the sensors and actuators in accordance with their safety demand and the respective manufacturer's information.

Ensuring signal redundancy

Ensure signal redundancy when connecting the signal lines of two-channel control devices and sensors to the inputs of the safety module.



WARNING: Loss of safety function due to cross-circuits and short circuits

Cross-circuits and short circuits can result in loss of the safety function.

- Prevent cross-circuits and short circuits by using a suitable cable installation.
- Use the possibility to implement cross-circuit detection.



For more information on topics such as signal redundancy caused by dual signals, two-channel sensors and cross-circuit detection, refer to the Help system of the SAFECONF configuration software.

Cable lengths

Many applications use large numbers of sensors or control devices. Depending on the size of the machine or system, a considerable amount of cabling may be required to wire the sensors.



WARNING: Loss of safety function due to interferences

To prevent interferences, always connect the two line ends both at the inputs and at the outputs.



NOTE: Reduced availability due to excessively long cables

If the maximum permissible cable lengths are exceeded, the safety modules automatically triggers the safety function, even if this has not been demanded. The availability of your system is thus undesirably reduced.

- Do not exceed the maximum permissible line lengths.

See "Maximum total line length" for the safe inputs of the PSR-TRISAFE modules on page 107 and 113.

PSR-TRISAFE-S and PSR-TRISAFE-M

Connecting the signal lines for the safety modules:

1. Connect the sensors to safe inputs **I0** to **I19**.
2. Connect the actuators to safe outputs **O0** to **O3**.
3. **Optional:** Additionally connect the actuators to ground switching outputs **O0-** (assigned to **O0**) and **O1-** (assigned to **O2**), to increase shutdown protection and cross-circuit protection.
4. **Optional:** Implement a signaling function by, for example, connecting a standard PLC or a signal unit to signal outputs **M0** to **M3**.
5. **Optional:** Implement cross-circuit detection for the "even" inputs **I0**, **I2**, **I4** ... **I18**, by wiring these to clock output **T0**.
For the "odd" inputs **I1**, **I3**, **I5** ... **I19**, use clock output **T1**.

Connecting signal lines for the PSR-TS-SDI8-SDIO4 safe extension module:

PSR-TS-SDI8-SDIO4

IO0 to IO3 as inputs:

1. Connect the sensors to safe inputs **I4** to **I11**.
2. Connect the sensors to safe inputs **IO0** to **IO3**.
3. **Required:** Implement a cross-circuit detection for inputs **IO0** to **IO3**, by wiring these to clock outputs **TM0** and **TM1**.

IO0 to IO3 as outputs:

1. Connect the sensors to safe inputs **I4** to **I11**.
2. Connect the actuators to safe outputs **O0** to **O3**.
3. **Optional:** Implement a signaling function by, for example, connecting a standard PLC or a signal unit to outputs **TM0** and **TM1**, which have been configured as signal output.
4. **Optional:** Implement cross-circuit detection for inputs **I4** to **I11**, by wiring these to outputs **TM0** and **TM1**, which are configured as clock outputs.

Connecting signal lines for the PSR-TS-SDOR4 safe extension module:

PSR-TS-SDOR4

1. Connect the actuators to the safe relay outputs **O0** to **O3**.
2. **Optional:** Implement a signaling function by, for example, connecting a standard PLC or a signal unit to signal outputs **M0** to **M3**.

7.4.2 Connecting the supply voltage

Switching on



The modules of the PSR-TRISAFE system do not have main switches. They are switched on by applying the supply voltage.

Once the supply voltage has been applied, the modules execute an initialization routine (all LEDs on). As soon as the “PWR” LED lights up continuously, the respective PSR-TRISAFE module is ready to operate.

PSR-TRISAFE-S and PSR-TRISAFE-M

Connecting the supply voltage for the safety modules:

1. Connect the power supply to the **A1** (24 V DC) and **A2** (0 V) terminal points.

The A1/A2 connections supply the logic of the safety modules, as well as the clock and signal outputs with power.

2. Connect the power supply to the **24 V** and **0 V** terminal points.

The 24 V/0 V connections supply the safe outputs and ground switching outputs of the safety modules.



WARNING: Loss of safety function

The use of unsuitable power supplies and the incorrect connection of the power supply can result in the loss of the safety function.

- Power to connections A1/A2 and 24 V/0 V on the base device of a PSR-TRISAFE system should be supplied exclusively via the same power supply.
- Power to all other participating devices in the system should also be supplied exclusively via the same power supply.
- Only use power supply units with safe isolation and SELV / PELV in acc. with EN 50178 / VDE 0160.



Connect both supply connections (A1/A2 and 24 V/0 V) for the safety module to work as intended.

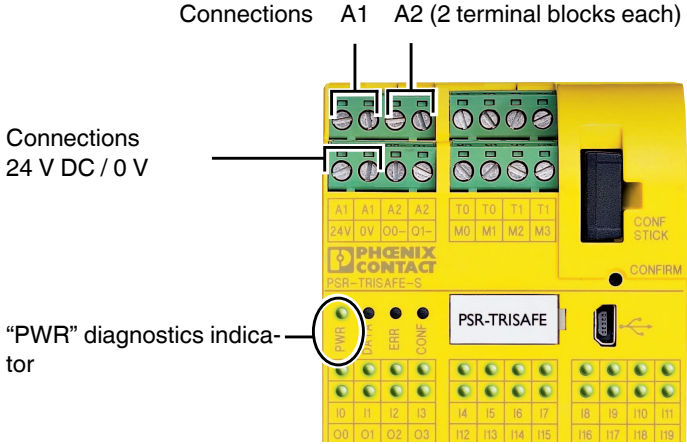

Figure 7-5 Connecting the PSR-TRISAFE-S/-M supply voltage



At the dual terminal block contacts A1 and A2, the supply voltage is available for supplying other sensors and control devices.

See also “Supply connections” on page 34.

PSR-TS-SDI8-SDIO4 and PSR-TS-SDOR4

Connecting the supply voltage for the safe extension modules:

1. Connect the power supply to the **A1** (24 V DC) and **A2** (0 V) terminal points of the respective safe extension module.

The A1/A2 connections supply the clock/signal outputs, as well as the inputs and outputs (PSR-TS-SDI8-SDIO4) or the signal outputs (PSR-TS-SDOR4).

The logic of the safe extension module is supplied with power via the yellow PSR-TBUS DIN rail connector.



WARNING: Loss of safety function

The use of unsuitable power supplies and the incorrect connection of the power supply can result in the loss of the safety function.

- Power to connections A1/A2 and 24 V/0 V on the base device of a PSR-TRISAFE system should be supplied exclusively via the same power supply.
- Power to all other participating devices in the system should also be supplied exclusively via the same power supply.
- Only use power supply units with safe isolation and SELV / PELV in acc. with EN 50178 / VDE 0160.



Connect both supply connections (A1/A2 and PSR-TBUS) for the safe extension module to work as intended.

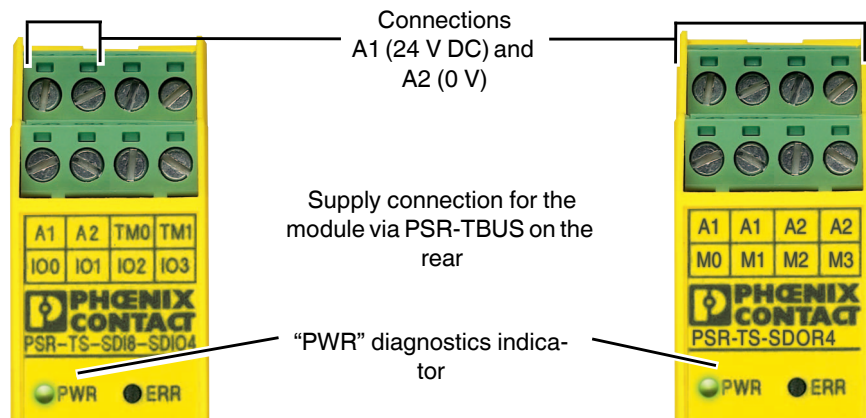

Figure 7-6 Connecting supply voltage: PSR-TS-SDI8-SDIO4 and PSR-TS-SDOR4

Also read:

- PSR-TS-SDI8-SDIO4: “Supply connections” on page 42
- PSR-TS-SDOR4: “Supply connections” on page 48

7.4.3 Typical connection of a PSR-TRISAFE system

Keep the following in mind when connecting your PSR-TRISAFE system with different devices:

Power supply and reference ground

- Power to all devices participating in the system should be supplied exclusively via the same supply voltage.
- Only use power supply units with safe isolation and SELV / PELV in acc. with EN 50178 / VDE 0160.
- Protect the power supply externally with a suitable fuse.
- Connect the GND connection on the output side of the power supply unit to the functional earth ground (FE) of the system.
- Make sure that all inputs and outputs of the system are connected to the same ground.

Additional devices

- Use only the yellow PSR-TBUS DIN rail connector to connect the safe extension modules.
- Use only the green TBUSDIN rail connector to connect standard extension devices (gateways).
- **Never** use the PSR-TBUS-TP dummy plug.



The following figure shows how to correctly connect the power supply for a PSR-TRISAFE system with different devices.

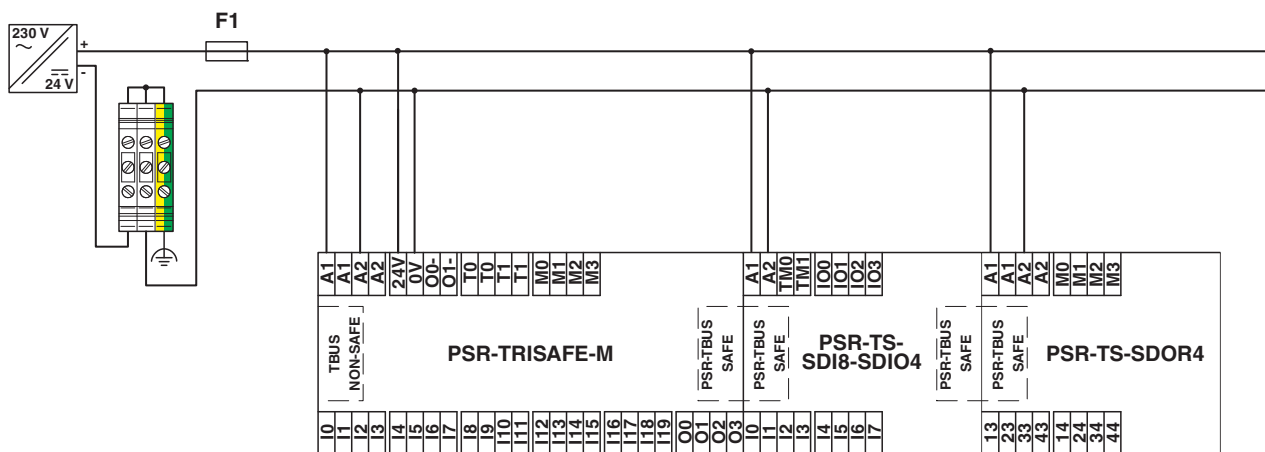

Figure 7-7 Power supply of the PSR-TRISAFE system

Key:

- F1** External fuse
- Functional earth ground (FE)

8 Firmware update

You can update the firmware of the modules of the PSR-TRISAFE system by means of the SAFECONF safe configuration software.

8.1 Safety notes for the firmware update

The following safety notes must be observed during and after the firmware update:

**WARNING: Standard operation**

While the firmware update is in progress, the PSR-TRISAFE system operates in standard mode. There is no absolute guarantee that the safety demand will be detected in this operating state.

- Therefore, make sure that running the firmware update will not lead to any hazardous situations.
- Prevent the machine from being started up unintentionally (by disconnecting the terminal blocks on the output side from the PSR-TRISAFE system, for example, and disconnecting the drives from the power supply).

**NOTE: Module damage**

Interrupting the connection between the PC and safety module during firmware update can damage the device.

Under certain circumstances, faulty or incomplete firmware installation can render communication between the PC and safety module impossible. In this case, the faulty installation cannot be corrected with the assistance of SAFECONF.

- Do **not** pull out the USB cable while the update is in progress.
- Do **not** switch off the safety module while the update is in progress.

**Validation/
Verification**

Once the firmware update is complete, validate and verify the safety application.

8.2 Requirements for firmware update

Before running the firmware update, make sure that:

- The PSR-TRISAFE-S or PSR-TRISAFE-M safety module is connected to the PC via the USB cable and is switched on.
- The IFS-CONFSTICK memory module has been inserted into the safety module.
- A project for the safety module has been loaded in the SAFECONF configuration software.
- The simulation mode of the SAFECONF software has been switched off.
- “Controller: Connected” and “Controller: Logged off” are displayed in the status bar of the SAFECONF configuration software.
- “Project: Write-protected” is displayed in the status bar of the SAFECONF configuration software.

8.3 Updating the firmware

1. To start the firmware update in the SAFECONF configuration software, select the “Safe controller, Firmware update” menu item.

The wizard, which will guide you through the update, is displayed.

2. Proceed as **described in detail in the help**.



You will find the topic “Firmware update” listed in the help contents of the SAFECONF configuration software.

See also “Accessing the software help” on page 80.

9 SAFECONF configuration software

9.1 Installing the software

Installation

The installation routine for the configuration software includes the installation of the driver for the USB interface. The driver enables communication between the PC and modules of the PSR-TRISAFE system.



To ensure that the configuration software detects the safety modules automatically and correctly, the software must be fully installed on the computer **before** the device is connected for the first time.

Proceed as follows:

1. **If you have downloaded the configuration software:**

Extract the downloaded file and start the installation program (setup file).

If you have purchased the PSR-SAFECONF BOX:

Insert the supplied CD-ROM in the drive. A menu will open automatically. Select "Install software" to start the installation program.



If you have deactivated the auto start option on your computer, manually open the "SAFECONF" folder on the CD-ROM and execute the setup file.

2. Select the desired language for the installation routine.



This selection also sets the language for the SAFECONF user interface, which is set when the software is started for the first time.

The installation program now guides you through the installation step by step.

3. Follow the on-screen instructions.

Once SAFECONF is installed, you will be prompted to install the drivers for the safety module.

4. Follow the on-screen instructions.

5. In the Windows dialog box for driver installation, select "Install the software automatically (recommended)".

Finally, a message appears indicating that the configuration software and drivers for the safety module have been fully installed.

9.2 Accessing the software help



You will find a description of the comprehensive functions of SAFECONF in the help for the software.

There are various ways of accessing the help:

- d) In the “?” menu, select “Help topics”.
The table of contents for the help appears.
Search for a help topic as described below.
- e) In an active dialog box or window, press <F1>.
The context-sensitive help for the active dialog box or window appears.
- f) In the connection editor, select an object and press <F1> in order to view information relating to that object.
For safe functions and functional blocks, general information about the objects can be accessed in this way.
- g) You can call up specific information on a functional block by means of the “Help” context menu item for the relevant functional block or function.

The diagram below illustrates the various options for opening the help and searching for information via context-sensitive help or via the contents or index.

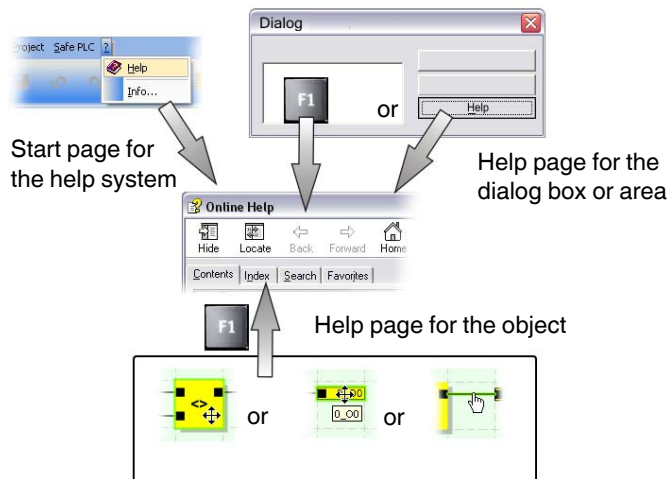

Figure 9-1 Accessing the help in the SAFECONF configuration software

10 Configuration and startup

Qualified personnel

Only qualified personnel may configure and start up the PSR-TRISAFE system. See "Qualified personnel" on page 9.

10.1 Example for configuration and startup



For detailed information, please refer to the sections specified and help files of the SAFECONF configuration software.

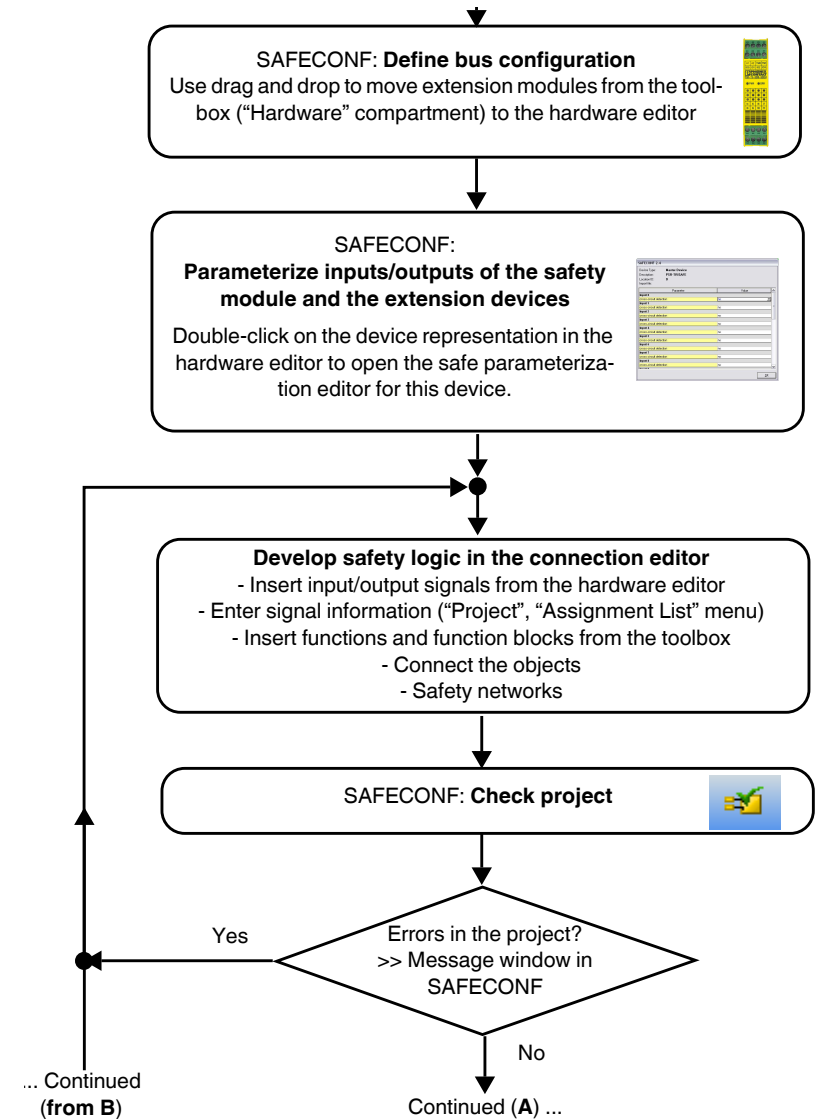

Figure 10-1 Flow chart: Example for configuration and startup (1 of 3)

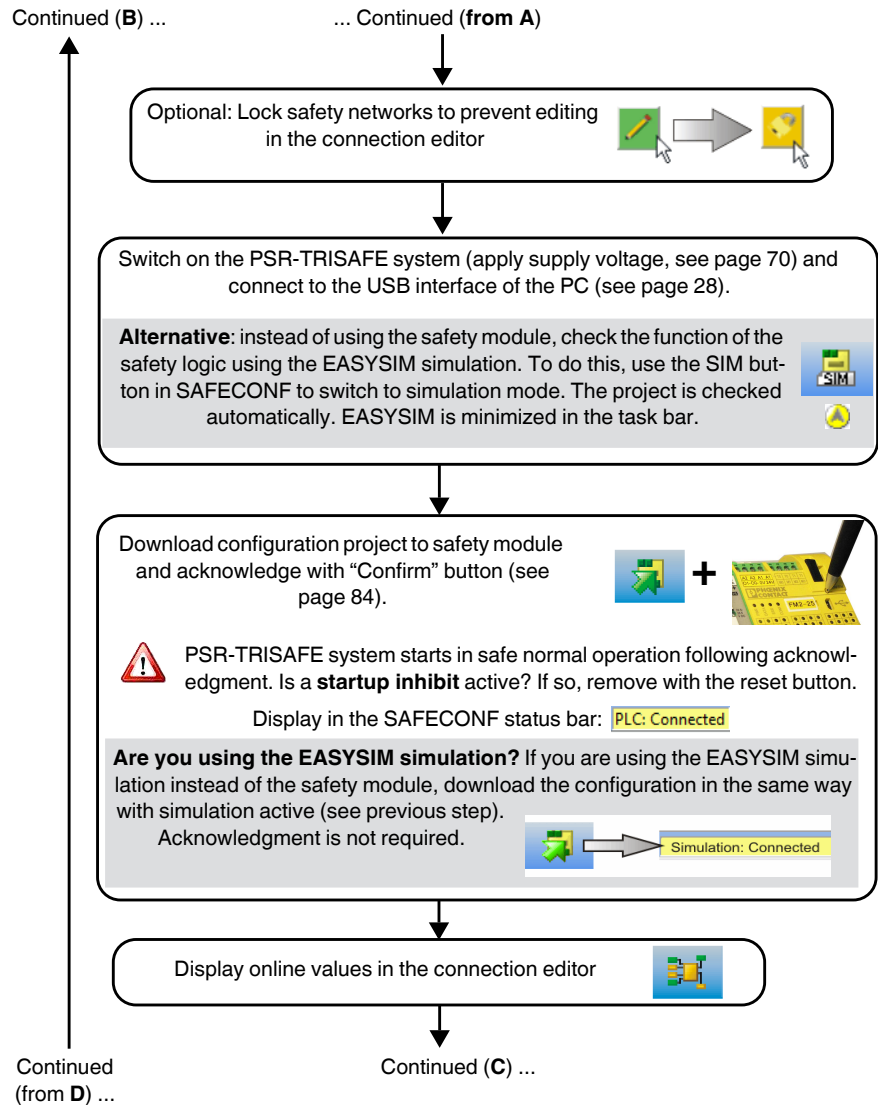

Figure 10-2 Flow chart: example for configuration and startup (2 of 3)

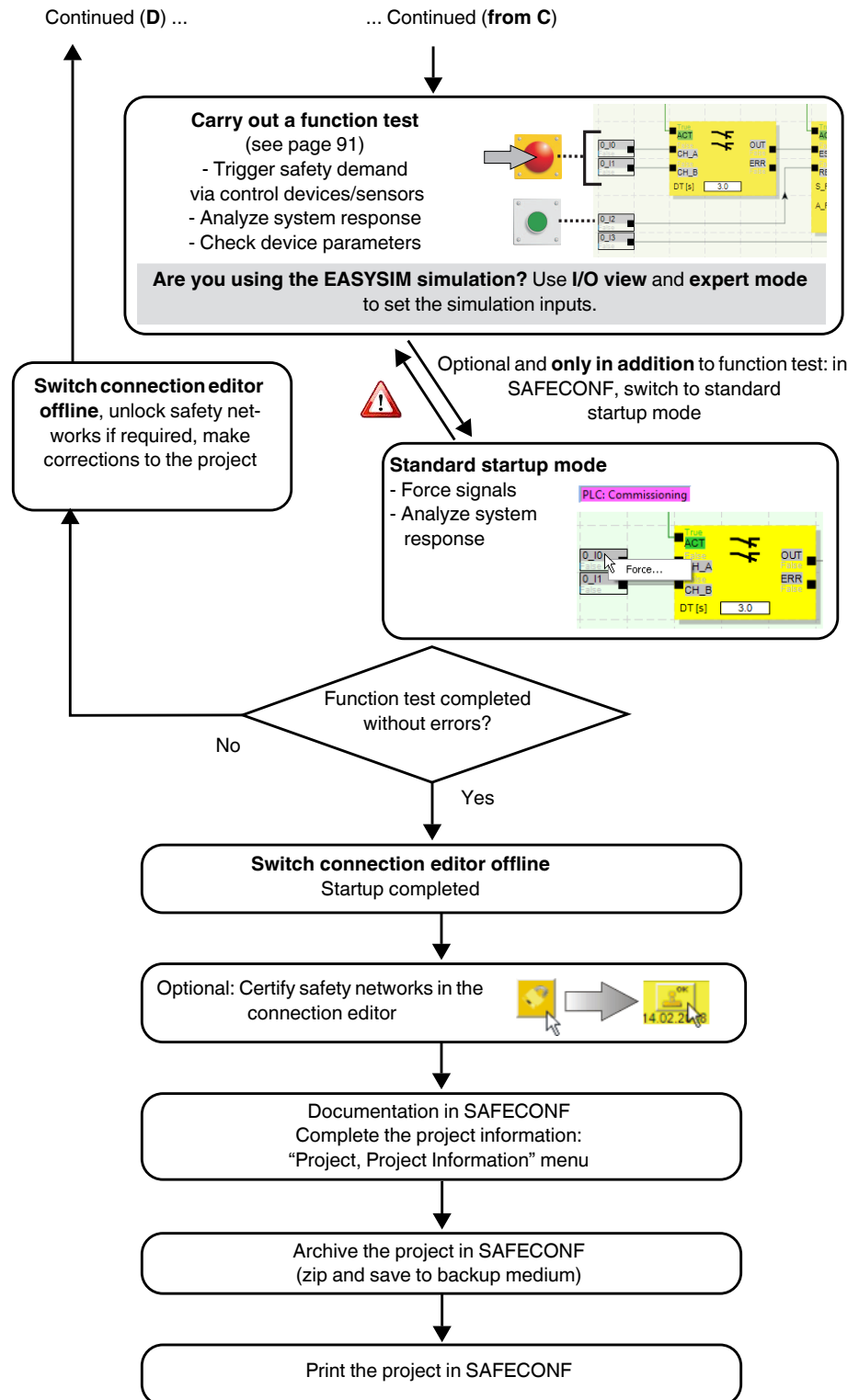

Figure 10-3 Flow chart: example for configuration and startup (3 of 3)

10.2 Downloading configuration from the SAFECNF configuration software

**WARNING: Risk of injury or damage to equipment due to unintentional system states or incorrect responses**

The safety module is in the startup phase, i.e., unintentional system states or incorrect responses cannot be ruled out. Operation is not safe.

- Make sure that triggering the safety demand does not endanger people or equipment.
- Do not enter any hazardous areas and make sure that no other persons can access the danger zone either.

You create the configuration, including the device parameterization, in the SAFECNF configuration software as a project. After completion, you load the configuration into the PSR-TRISAFE-S or PSR-TRISAFE-M safety module. This data is usually transmitted via the USB interface of the safety module.



Alternatively, you can also download the configuration by inserting an IFS-CONFSTICK that contains the relevant data.

For further information, please refer to “Downloading the configuration using the IFS-CONFSTICK memory module” on page 88.

To download the configuration, proceed as follows:

1. Ensure the following:
 - The safety module is on.
 - The SAFECNF configuration software is installed on the configuration computer (this installation also includes the required drivers).
 - The SAFECNF configuration software has been started.
 - A IFS-CONFSTICK memory module has been inserted into the safety module. If this is not the case, the configuration cannot be downloaded.
2. Connect the USB cable to the safety module (mini-USB plug, 5-pos., maximum cable length of 3 m) and to a USB port on the PC.

**NOTE: Electrostatic discharge**

The safety modules contain components that can be damaged or destroyed by electrostatic discharge. When handling the USB interface, observe the necessary safety precautions against electrostatic discharge (ESD) in acc. with EN 61340-5-1 and IEC 61340-5-1.

Once the connecting cable has been connected, the appropriately configured PC detects the safety module automatically and indicates the safety module status at the bottom right in the status bar.



Figure 10-4 USB connection between PC and safety module

Logging in with controller password

The project can only be downloaded to the safety module if you have logged on in SAFECONF with the correct **controller password**.

3. In the “Safe Controller” menu, select “Log On”, enter the controller password in the dialog box, and click “OK”.
4. Load the project created in SAFECONF into the safety module by clicking the symbol shown in the toolbar.



The prerequisite for this is that the current project has been tested in advance, and the test was completed **without errors** (see SAFECONF help).

Is there already a project on the safety module?

If the status bar has a yellow “Controller: No project” entry on the right, the project is sent to the safety module without any further prompts.

If another project or another version of the same project already exists on the safety module and is being executed, a corresponding dialog box appears, indicating this fact.

- Click “Yes” in this dialog box to overwrite the current controller configuration on the safety module.

Data transmission

During data transmission

- A progress indicator is displayed in the SAFECONF status bar.
- The “CONF” status indicator flashes quickly on the safety module (approximately 6 Hz).



If data transmission is interrupted during the download, see “Problems and solutions” starting on page 99 for information on how to solve this problem.

Following successful data transmission

- The “CONF” status indicator flashes slowly on the safety module (approximately 1.5 Hz).
- A “Download succeeded” dialog appears in the configuration software.

If the “Download succeeded” dialog is being displayed, proceed with the next steps in the following order:



Please note:

First acknowledge the configuration on the safety module (see step) ...

... before clicking “OK”.

Figure 10-5 Dialog box following successful data transmission

5. Confirm the new configuration by pressing the “Confirm” button using a pen (see figure 10-6).



WARNING: Danger due to activated outputs

Following acknowledgment, the safety module starts running immediately. Provided that no startup inhibit that needs to be canceled manually is active, outputs may be activated immediately after startup.

- Make sure that the safety module startup will not lead to any hazardous situations.

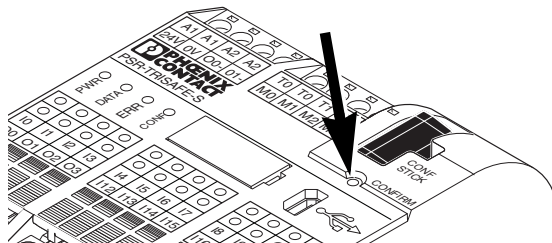

Figure 10-6 Confirming the configuration with the “Confirm” button

Initialization

The safety module is then reinitialized (all diagnostics indicators are on briefly) and then switches to safe normal operation (only “PWR” LED on).

Stopping the data transmission

6. Close the dialog in the configuration software and click “OK”.

Startup inhibit



Startup inhibit active?

WARNING: Unintentional machine startup

Deactivating the startup inhibit can lead to unintentional machine startup.

- Before deactivating the startup inhibit, make sure that the deactivation will not cause the machine to switch to a hazardous state.
- When planning the machine or system, make sure that deactivating the startup inhibit is only possible if the danger zone is visible.

If a startup inhibit has been preset in the configuration, it will be active following startup. An active startup inhibit must be canceled by pressing a reset button which is connected to the safety module according to the configuration.

For additional information, please refer to “System startup and restart behavior” on page 19.



If the safety module is not initialized correctly, proceed as described in “Problems and solutions” on page 99.

Next steps

Next, continue with the function test.

See “Function test” on page 91.

Check values (CRC)



Check values (CRC)

To ensure that any distortions to the configuration data during transmission to the safety module can be reliably detected, a check value (CRC) is calculated in the configuration software when the project is checked.

The safety module also determines the check value for the downloaded data.

If the check values on the safety module and in the configuration software are identical, all data has been saved on the safety module undistorted. If the check values differ, a corresponding error message is output.

Deviating check value due to subsequent changes

The check value (CRC) will also differ if subsequent changes have been made to the project in the configuration software, but have not yet been downloaded to the safety module.

Note

The following activities are already considered to be changes in the project:

- Moving an object
- Changes to the project documentation

Recommendation

Document the check value (CRC) in the acceptance test record of the machine after startup and subsequent validation, in order to later be able to recognize subsequent project changes.

10.3 Downloading the configuration using the IFS-CONFSTICK memory module



WARNING: Risk of injury or damage to equipment due to unintentional system states or incorrect responses

The safety module is in the startup phase, i.e., unintentional system states or incorrect responses cannot be ruled out. Operation is not safe.

- Make sure that triggering the safety demand does not endanger people or equipment.
- Do not enter any hazardous areas and make sure that no other persons can access the danger zone either.

Configurations can not only be downloaded via the USB interface, but can also be copied with the help of the IFS-CONFSTICK memory module. This means that you can transfer the configuration of one device to other safety modules. This is useful if no configuration computer is available at an installation location or if you wish to transfer the configuration to a new device on device replacement.



If you want to copy data from one to several memory modules or want to delete the data of the memory modules, you can use the COPYSTATION-IFS copy and delete station. See "Accessories" on page 126.

To replace the IFS-CONFSTICK memory module, proceed as follows. This sequence ensures that the active configuration is not overwritten by accidental insertion of an IFS-CONFSTICK.

Removing the IFS-CONFSTICK

1. The IFS-CONFSTICK may not be replaced during operation. If the safety module is already running, perform the following steps.
 - h) First, shut down the machine.
 - i) Switch the safety module off.
 - j) Remove the current IFS-CONFSTICK.



When the IFS-CONFSTICK has been removed correctly, all of the safety module outputs are in a safe and de-energized state (FALSE). During the time when the IFS-CONFSTICK is not inserted, the safety module has no function.

If the IFS-CONFSTICK is not removed correctly, the safety module also displays an error message.

Inserting the new IFS-CONFSTICK



WARNING: Danger due to activated outputs

Once you have downloaded the configuration by exchanging the IFS-CONFSTICK, the safety module starts program execution. Provided that no startup inhibit that needs to be canceled manually, is active, outputs may be activated immediately.

- Make sure that the safety module startup will not lead to any hazardous situations.

2. Insert the new IFS-CONFSTICK in the safety module (which must still be switched off). The IFS-CONFSTICK is mechanically coded and cannot be inserted in the device incorrectly.
3. Switch the safety module on and wait until it has initialized. All four diagnostics indicators light up once during initialization. The safety module now detects the previously unknown IFS-CONFSTICK and indicates this by making the "CONF" diagnostics indicator flash.

4. Remove the IFS-CONFSTICK again.
5. Press the “Confirm” button on the device and **hold** it down.
6. Reinsert the IFS-CONFSTICK **while** holding down the “Confirm” button.

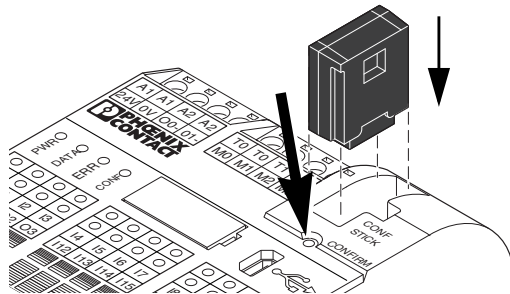

Hold down the “Confirm” button while inserting the IFS-CONFSTICK

Figure 10-7 Inserting the IFS-CONFSTICK

7. Release the “Confirm” button once the IFS-CONFSTICK is inserted properly. The safety module now initializes with the new configuration.

Startup inhibit

Startup inhibit active?



WARNING: Unintentional machine startup

Deactivating the startup inhibit can lead to unintentional machine startup.

- Before deactivating the startup inhibit, make sure that the deactivation will not cause the machine to switch to a hazardous state.
- When planning the machine or system, make sure that deactivating the startup inhibit is only possible if the danger zone is visible.

If a startup inhibit has been preset in the configuration, it will be active following startup. An active startup inhibit must be canceled by pressing a reset button which is connected to the safety module according to the configuration.

For additional information, please refer to “System startup and restart behavior” on page 19.



If the safety module is not initialized correctly, proceed as described in “Problems and solutions” on page 99.

10.4 Uploading the configuration from the safety module

Projects downloaded to the safety module are saved there and can be uploaded to the PC and the configuration software again if required.

This may be required, for example, if a project has to be read from the safety module for diagnostic purposes.



It is possible to upload a project from the safety module to the configuration software without the controller password. However, to edit the uploaded project you will need the correct project password.

To upload the project, proceed as follows:

1. If a project is currently open in the configuration software, save it before uploading the required project from the safety module.
2. Exit startup mode and the online mode of the configuration software.



The “Online Values” icon must not be selected prior to starting the upload and the status bar must show the controller status “Controller: Connected”.

3. Click on the “Upload” icon in the toolbar:



4. Click “Yes” in the dialog box to confirm the upload.

Transmission from the safety module to the PC starts and a progress indicator is displayed in the status bar of the SAFECONF configuration software.

5. If a project with the same name already exists on the PC, a prompt will appear where you must decide whether you want to overwrite the project which is already loaded or not.

In this dialog box, click the respective buttons:

- “**Yes**” to overwrite the data of the existing project with that of the project which has just been uploaded.
Overwriting means that the current data will be lost and it will not be possible to recover it.
- “**No**” to save the uploaded project under a different name or in a different directory.
The “Save Project As” dialog box appears.
Here, select a directory, enter a file name, and click “Save”.

6. You are now asked to enter the project password.

Once you have entered the password you can edit and check the project, load it to the safety module, and start it up there as usual.

10.5 Function test



WARNING: Risk of injury or damage to equipment due to unintentional system states or incorrect responses

The safety module is in the startup phase, i.e., unintentional system states or incorrect responses cannot be ruled out. Operation is not safe.

- Make sure that triggering the safety demand does not endanger people or equipment.
- Do not enter any hazardous areas and make sure that no other persons can access the danger zone either.

Validate

Once the project has been uploaded to the safety module, it is executed there following manual acknowledgment. Perform a function test to ensure that the safety module and therefore the safety logic and all of the cabling are working correctly.

Online mode in SAFECONF

For the function test, you can switch the SAFECONF configuration software to online mode. Then the online values are read from the safety module cyclically and are displayed in the connection editor and hardware editor.

Safety demand / Monitoring signals

You can trigger the safety demand by activating the safe control devices, e.g. by pressing the emergency stop control device or opening the safety door. Now you can precisely analyze the behavior of the safety logic in the configuration software, as in online mode, the connection editor displays the value of every signal "live".

10.5.1 Performing function test using online mode

Connecting/ Logging in

1. Connect the safety module, which is switched on, to the configuration computer via the USB interface.
2. Start the SAFECONF configuration software, and log onto the safety module.
The status bar in the SAFECONF configuration software displays the following entry on the right-hand side.

PLC: Logged on | PLC: Connected



The system can only display online values if the project in the safety module and the project in the configuration system are identical.

If you have made a change to a project after startup, you must check the project and download it to the safety module again.

Only then can you display online values.

Note

The following activities are already considered to be changes in the project:

- Moving an object
- Changes to the project documentation

- Switch the SAFECONF configuration software to online mode by clicking on the “Display online values” icon in the toolbar:



Signal lines and function block connections are now displayed in the connection editor in different colors according to their state (TRUE/FALSE) and together with the current values. The hardware editor also supports the function test by means of “lit” LEDs.

- Trigger a safety demand via the safe control devices.
- Monitor the response of the machine and the configuration by means of the online values in the connection editor.

Example:

Emergency stop not pressed, no safety demand

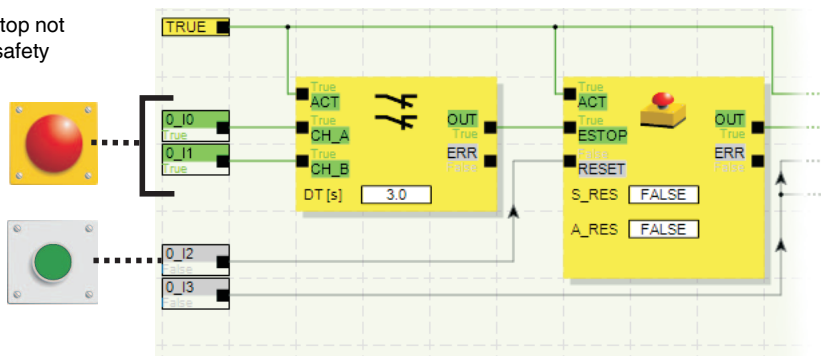

Safety demand

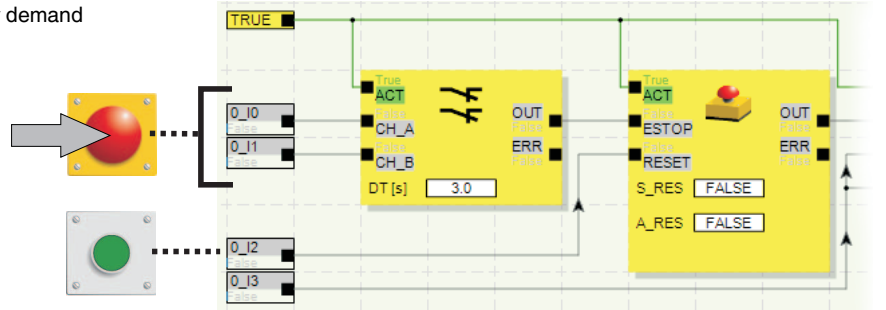

Figure 10-8 Example of a function test for the safety system using the online mode of SAFECONF

11 Diagnostics

SAFECONF diagnostics



For information on hardware diagnostics, wiring checks and tool tips, refer to the help of the SAFECONF configuration software.

Diagnostics via gateways

You can connect your PSR-TRISAFE system to a higher-level controller via gateways. Diagnostics readouts are bus-specific.



For information on gateway diagnostics, refer to the following application note:
AH EN PSR-TRISAFE System Diagnostics
See phoenixcontact.net/products.

You can find gateways that are suitable for use with the PSR-TRISAFE system in the accessories section "Gateways" on page 127.

11.1 Diagnostics using LED indicators on the module

The following tables list the possible indicator combinations for the diagnostics and status indicators and their meanings. A distinction is made between slow flashing and fast flashing LEDs.

The LED symbols in the tables mean:

- LED is off
- ☀ LED is on
- ⚡ LED is flashing: slow \approx 2 Hz / fast \approx 6 Hz
- S** If there is an **S** below an LED symbol, this LED indicator only applies to the **PSR-TRISAFE-S**.
- M** If there is an **M** below an LED symbol, this LED indicator only applies to the **PSR-TRISAFE-M**.

11.1.1 PSR-TRISAFE-S and PSR-TRISAFE-M

Table 11-1 Diagnostic indicators for PSR-TRISAFE-S and PSR-TRISAFE-M

PWR (green)	DATA (green)	ERR (red)	CONF (green)	I0 ... I19	O0 ... O3	Meaning
●	●	●	●			Device is switched off No power supply at A1 and A2
☀	☀	☀	☀			Initialization phase after power up or after the restart subsequent to the “Confirm” button being pressing (duration: max. 4 s)
☀	●	●	☀			Status at initial startup No configuration data present on the IFS-CONFSTICK. <ul style="list-style-type: none"> Download project with SAFECONF
☀	●	☀	☀			IFS-CONFSTICK not present <ul style="list-style-type: none"> Insert IFS-CONFSTICK and apply power supply.
☀	●	●	☀ ≈ 2 Hz			Acknowledgment of new configuration required after download. <ul style="list-style-type: none"> Press “Confirm” button on the device.
☀	●	●	☀ ≈ 6 Hz			Acknowledgment of new configuration required after transfer via IFS-CONFSTICK. ☑ For sequence, see 10.3 on page 88
☀	☀	●	☀ ≈ 2 Hz			Acknowledgment required after change of extension device <ul style="list-style-type: none"> Press “Confirm” button on the device.
☀	●	●	●			PSR-TRISAFE-S: Normal operation Configuration data present on the IFS-CONFSTICK PSR-TRISAFE-M: Normal operation without connected extension devices (TBUS communication) Configuration data present on the IFS-CONFSTICK.
☀	☀	●	●			PSR-TRISAFE-M: Normal operation with connected extension devices (TBUS communication)
☀	● S ☀ M	☀	●			Limited operation with error affecting at least one input/output <ul style="list-style-type: none"> Remove error Deactivate input/output Press “Confirm” button on the device. (Duration: min. 15 s)
☀	●	☀ ≈ 6 Hz	●			Fault present <ul style="list-style-type: none"> Read error code with SAFECONF

Table 11-1 Diagnostic indicators for PSR-TRISAFE-S and PSR-TRISAFE-M

PWR (green)	DATA (green)	ERR (red)	CONF (green)	I0 ... I19	O0 ... O3	Meaning
	● S M		●	 ≈ 6 Hz	●	<p>Cross circuit has occurred.</p> <ul style="list-style-type: none"> • Check wiring of I/O devices • Press “Confirm” button (duration: min. 3 s) <div style="border: 1px solid black; padding: 5px; display: inline-block;"> PSR-TRISAFE-M: Only in conjunction with safe extension module. </div>
	● S M		●	●	 ≈ 6 Hz	<p>Short circuit at the safe output (GND applied to a safe output)</p> <ul style="list-style-type: none"> • Press “Confirm” button on the device. (Duration: min. 15 s) <div style="border: 1px solid black; padding: 5px; display: inline-block;"> PSR-TRISAFE-M: Only in conjunction with safe extension module. </div>
	● S M		●	 ≈ 6 Hz	●	<p>Short circuit at clock output (GND applied to a clock output).</p> <ul style="list-style-type: none"> • Remove the short circuit at the clock output. • Press “Confirm” button on the device. (Duration: min. 15 s) <div style="border: 1px solid black; padding: 5px; display: inline-block;"> PSR-TRISAFE-M: Only in conjunction with safe extension module. </div>

Table 11-2 Status indicators for safe inputs and outputs for PSR-TRISAFE-S and PSR-TRISAFE-M

LED	State	Meaning
For each input ("I0" to "I19")	●	There is no switching signal at the relevant input.
	☀	Switching signal active at the input.
	☀ Long on Short off	Wiring check at an active input or non-equivalence input
	☀ Long off Short on	Wiring check at an inactive input or non-equivalence input
For each output ("O0" to "O3")	●	Output is not active
	☀	Output is active
	☀ Long on Short off	Wiring check at an active output
	☀ Long off Short on	Wiring check at an inactive output

11.1.2 PSR-TS-SDI8-SDIO4

Table 11-3 Diagnostic indicators for PSR-TS-SDI8-SDIO4

PWR (green)	ERR (red)	Meaning
●	●	Device is switched off No power supply at 24 V/0 V or at PSR-TBUS
☀	☀	Initialization phase after power up (duration: max. 4 s).
☀	●	Normal operation
☀	☀	Limited operation with error affecting at least one input/output <ul style="list-style-type: none"> Remove error Deactivate input/output Press "Confirm" button at PSR-TRISAFE-M basic device (duration: min. 15 s) A flashing LED at an input or output signals an error affecting the corresponding signal (see table 11-4).
☀	☀ ≈ 6 Hz	Fault present <ul style="list-style-type: none"> Read error code with SAFECONF

Table 11-4 Status indicators for safe inputs and outputs for PSR-TS-SDI8-SDIO4

LED	State	Meaning
For each input ("I4" to "I11") and for "IO0" to "IO3", if these are configured as safe inputs	●	There is no switching signal at the relevant input.
	☀	Switching signal active at the input.
	☀ Long on Short off	Wiring check at an input or non-equivalence input
For "IO0" to "IO3", if these are configured as safe outputs	●	Output is not active
	☀	Output is active
	☀ Long on Short off	Wiring check at an output

11.1.3 PSR-TS-SDOR4

Table 11-5 Diagnostic indicators for PSR-TS-SDOR4

PWR (green)	ERR (red)	Meaning
●	●	Device is switched off No power supply at 24 V/0 V or at PSR-TBUS
☀	☀	Initialization phase after power up (duration: max. 4 s).
☀	●	Normal operation
☀	☀	Limited operation with error affecting at least one output. <ul style="list-style-type: none"> Remove error Deactivate output Press "Confirm" button at PSR-TRISAFE-M basic device (duration: min. 15 s) A flashing LED at an output signals an error (see table 11-6).
☀	☀ ≈ 6 Hz	Fault present <ul style="list-style-type: none"> Read error code with SAFECONF

Table 11-6 Status indicators of the safe outputs for PSR-TS-SDOR4

LED	State	Meaning
For "O0" to "O3"	●	Output is not active
	☀	Output is active
	☀ Long on Short off	Wiring check at an output

12 Problems and solutions

In this chapter, you can find a list of possible problems which may occur when working with the configuration software and the safety modules (PSR-TRISAFE-S and PSR-TRISAFE-M), as well as the safe extension modules (PSR-TS-SDI8-SDIO4 and PSR-TS-SDOR4). The following descriptions are divided into categories corresponding to the different sections of the configuration software.

12.1 General

Table 12-1 Solutions for general problems

Problem	Solution
When the SAFECNF safe configuration software was launched, the installation check identified a faulty system file. A corresponding message window appears.	Uninstall the safe configuration software, then reinstall it by running the setup program from the installation CD.
The operating system test routine has identified that you are trying to launch the SAFECNF configuration software on an operating system that is not supported.	Install an operating system supported by the SAFECNF configuration software (see “System requirements of the configuration software SAFECNF” on page 124) or consult the technical support team to find out whether a newer version of SAFECNF is available, which supports your current operating system.
An error has occurred (accompanied by a corresponding message) which cannot be removed using any of the measures described here.	Please contact Phoenix Contact technical support.
The SAFECNF safe configuration software or one of its functions is not behaving as described in the user documentation or the help.	Please contact Phoenix Contact technical support.

12.2 Graphical connection editor

Table 12-2 Solutions for problems with the graphical connection editor

Problem	Solution
You have attempted to open a project, but the safety logic could not be loaded due to a checksum error. A corresponding message window appears.	The project concerned is corrupted and can no longer be used. Use the latest backup copy of the project (as described in the help under “Zipping and extracting projects”). If the problem persists, please contact the technical support team of Phoenix Contact.
During editing, a message window appears where the connection editor reports corrupted data, a sporadic error or a systematic error.	The project is closed automatically. You do not have the opportunity to save the most recently made changes. If the problem persists when the project is reopened, please contact the technical support team of Phoenix Contact.

12.3 Parameterization editor

Table 12-3 Solutions for problems with the parameterization editor

Problem	Solution
You have attempted to open the parameterization editor, but the data could not be loaded due to a checksum error. A corresponding message window appears.	The project can no longer be used, as the parameterization data cannot be deleted. Use the latest backup copy of the project (as described in the help under “Zipping and extracting projects”).
The parameterization editor responds unexpectedly to an entry in the parameter table by displaying something other than what has been entered or selected, for example. This may be traced back to a sporadic error or a systematic error.	Undo the last entry (by pressing <Ctrl>+<Z>), then repeat the entry. If the result is still incorrect, please contact the technical support team of Phoenix Contact.
During editing, a message window appears where the parameterization editor reports corrupted data, a sporadic error or a systematic error.	The project is closed automatically. You do not have the opportunity to save the most recently made changes. If the problem persists when the project is reopened, please contact the technical support team of Phoenix Contact.

12.4 Online communication between SAFECONF and the safety module

Table 12-4 Solutions for communication problems between SAFECONF and the safety module

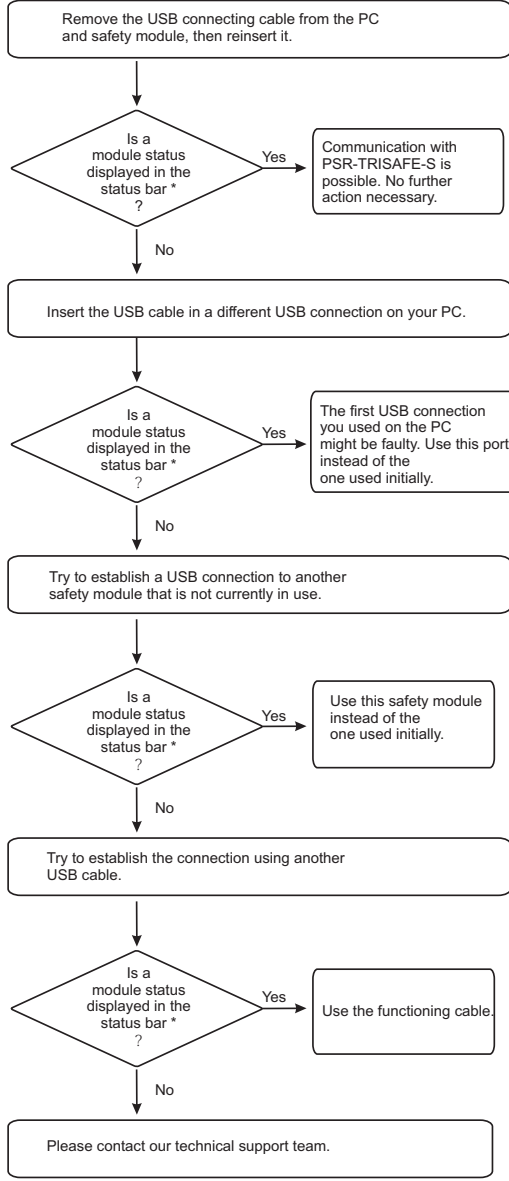
Problem	Solution									
<p>A connection cannot be established to the safety module.</p> <p>The status bar does not display a status for the safety module (neither "Timeout", nor "No project", nor "Connected"; see information under the following diagram).</p> <p>The status bar looks like this, for example:</p> 	<p>Proceed as follows:</p>  <pre> graph TD A[Remove the USB connecting cable from the PC and safety module, then reinsert it.] --> B{Is a module status displayed in the status bar * ?} B -- Yes --> C[Communication with PSR-TRISAFE-S is possible. No further action necessary.] B -- No --> D[Insert the USB cable in a different USB connection on your PC.] D --> E{Is a module status displayed in the status bar * ?} E -- Yes --> F[The first USB connection you used on the PC might be faulty. Use this port instead of the one used initially.] E -- No --> G[Try to establish a USB connection to another safety module that is not currently in use.] G --> H{Is a module status displayed in the status bar * ?} H -- Yes --> I[Use this safety module instead of the one used initially.] H -- No --> J[Try to establish the connection using another USB cable.] J --> K{Is a module status displayed in the status bar * ?} K -- Yes --> L[Use the functioning cable.] K -- No --> M[Please contact our technical support team.] </pre> <p>* Possible module status on existing connection:</p> <table border="0"> <tr> <td style="border: 1px solid black; background-color: #ffffcc; padding: 2px;">Controller: Timeout</td> <td style="padding: 2px;">→</td> <td style="padding: 2px;">Temporary during initialization</td> </tr> <tr> <td style="border: 1px solid black; background-color: #ffffcc; padding: 2px;">Controller: No project</td> <td style="padding: 2px;">→</td> <td style="padding: 2px;">Download project</td> </tr> <tr> <td style="border: 1px solid black; background-color: #ffffcc; padding: 2px;">Controller: Connected</td> <td style="padding: 2px;">→</td> <td style="padding: 2px;">Start function test</td> </tr> </table>	Controller: Timeout	→	Temporary during initialization	Controller: No project	→	Download project	Controller: Connected	→	Start function test
Controller: Timeout	→	Temporary during initialization								
Controller: No project	→	Download project								
Controller: Connected	→	Start function test								

104286a019.eps

Table 12-4 Solutions for communication problems between SAFECONF and the safety module

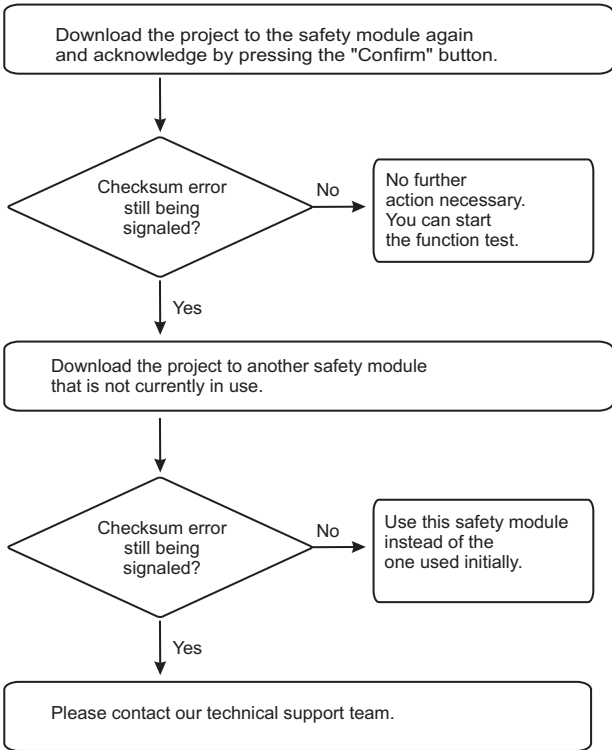
Problem	Solution
<p>Transmission has been interrupted during the download procedure.</p>	<ol style="list-style-type: none"> 1. Start transmission again. 2. If the download fails once more, remove the USB connecting cable from the interface on the configuration computer and reinsert it. 3. Once the safety module has been detected correctly (see display in the status bar), restart the download procedure.
<p>Following successful project download, the SAFECONF safe configuration software identifies that the checksum of the project on the safety module does not match that of the project on the PC. A corresponding message window appears.</p>	<p>Proceed as follows:</p>  <pre> graph TD A[Download the project to the safety module again and acknowledge by pressing the "Confirm" button.] --> B{Checksum error still being signaled?} B -- No --> C[No further action necessary. You can start the function test.] B -- Yes --> D[Download the project to another safety module that is not currently in use.] D --> E{Checksum error still being signaled?} E -- No --> F[Use this safety module instead of the one used initially.] E -- Yes --> G[Please contact our technical support team.] </pre> <p style="text-align: right;">104286a020.eps</p>

12.5 Communication between the safety module and the safe extension module

Table 12-5 Solutions for communication problems between the safety module and the safe extension module

Problem	Solution
<p>Communication between the safety module and the safe extension module via the DIN rail connector (PSR-TBUS) has been interrupted.</p> <p>The "Data" LED on the safety module is off.</p>	<p>Check whether all extension modules are correctly connected to the safety module. A connection is correct if there is a PSR-TBUS plug under each extension module and the plug-in connection has been made properly (the module must snap into place).</p> <p>Check whether the power supply at each extension module has been connected and switched on correctly.</p>

12.6 Safety module messages

Table 12-6 Solutions for messages from the safety module

Problem	Solution
<p>Following acknowledgment of the newly loaded configuration, the safety module is not initialized correctly ("Controller: Error" in the status bar and flashing "ERR" status indicator on the safety module).</p>	<ol style="list-style-type: none"> 1. Switch the safety module off and on again. 2. Download the project to the safety module again and acknowledge the new configuration by pressing the "Confirm" button on the device. 3. If the problem persists, please contact our technical support team.
<p>The safety module reports an internal error.</p>	<p>Please contact Phoenix Contact technical support.</p>

13 Maintenance, repair, decommissioning, and disposal

13.1 Maintenance

The modules of the PSR-TRISAFE system are maintenance free. Depending on the application and connected I/O devices, the function of the I/O devices and the safety chain must be tested regularly.

Carry out maintenance on connected I/O devices (e.g., light grid) according to the manufacturer specifications.

For the duration of use and the proof test interval at a high or low demand rate for the modules of the PSR-TRISAFE system, refer to the technical data.

See "Technical data and ordering data" on page 107.

13.2 Repair

It is prohibited for the user to carry out repair work or make modifications to the module. The housing must not be opened. If the housing is opened, the function of the PSR-TRISAFE modules can no longer be ensured.

In the event of an error, send the module to Phoenix Contact or contact Phoenix Contact immediately and engage a service engineer.

13.3 Decommissioning and disposal

Carry out decommissioning according to the requirements of the machine or system manufacturer.

When decommissioning the PSR-TRISAFE system or parts of the system, ensure the following for the modules used:

Fate of the module	Measure
The modules will continue to be used correctly.	Observe the storage and transport requirements according to the technical data: see Section 14 "Technical data and ordering data" on page 107.
Modules will no longer be used.	Dispose of modules in accordance with the environmental regulations. Make sure that the modules can never be reused.

14 Technical data and ordering data

14.1 Technical data of the PSR-TRISAFE-S and PSR-TRISAFE-M

Logic / Supply A1/A2	
Rated control circuit supply voltage U_S	24 V DC (A1/A2)
Permissible range	18 V DC ... 30 V DC (incl. all tolerances, incl. residual ripple)
Rated control supply current I_S	110 mA, typical
Limiting continuous current	max. 6 A (for looped-through current paths A1/A1 and A2/A2, see "Double terminal block contacts A1/A1 and A2/A2" on page 35)
Filter time	20 ms, typically (load-dependent, in the event of voltage dips at U_S)
Status indicator	3 x LED green 1 x LED red
Protective circuit	Yes, within scope of operating voltage limits
Safe digital inputs I0 to I19	
Quantity	10 (two-channel, up to SIL 3) 20 (single-channel, up to SIL 2)
Type	Digital, type HTL
Input voltage range "0" signal	0 V DC to 5 V DC (for safe Off)
Input voltage range "1" signal	11 V DC ... 30 V DC
Typical current consumption at U_S	4 mA
Maximum total line length	2000 m
Status indicator	20 x LED green (1 LED per input)
Safe digital outputs O0 to O3 and ground switching outputs O0- and O1-	
Quantity (type)	4 (safe semiconductor outputs, up to Cat. 4 in acc. with EN ISO 13849-1) 2 (ground switching outputs)
Nominal voltage	24 V DC (supply through 24 V/0 V)
Permissible range	18 V DC ... 30 V DC (incl. all tolerances, incl. residual ripple)



WARNING: Loss of safety function

The use of unsuitable power supplies and the incorrect connection of the power supply can result in the loss of the safety function.

- Only use power supply units with safe isolation and SELV / PELV in acc. with EN 50178 / VDE 0160.
- Connect the GND connection on the output side of the power supply unit to the functional earth ground (FE) of the system.

PSR-TRISAFE system

Safe digital outputs O0 to O3 and ground switching outputs O0- and O1-

Limiting continuous current	2 A (per channel, see Derating) 2 A (total current of all outputs)
Maximum output voltage in the low state	< 5 V
Maximum leakage current in the low state	2 mA



WARNING: Loss of safety function

Switching the load at the maximum leakage current can result in the loss of the safety function.

- Please note that at this current, the load must not switch to or remain in the ON state.
- Please take this into consideration when selecting the actuator.

Load	
Capacitive ¹	max. 1 µF (electronic components)
Inductive ²	- (see "Protective circuit")
Test pulses	< 1 ms
Protective circuit	Yes, within scope of operating voltage limits
Short-circuit protection	Yes
Status indicator	4 x LED green (1 LED per output)

¹ When using electromechanical components (e.g., contactors), the capacitive load can be disregarded.

² Connect a suitable and effective protective circuit to inductive loads.

Clock outputs T0 and T1

Quantity	2
Type	digital
Voltage	24 V DC (supply through 24 V/0 V)
Limiting continuous current	100 mA
Test pulses	< 1 ms
Short-circuit protection	Yes

Signal outputs M0 to M3

Quantity	4
Type	digital
Voltage	24 V DC (supply through 24 V/0 V)
Limiting continuous current	100 mA
Short-circuit protection	Yes

Times

Response time	max. 30 ms (plus response time of PSR-TS-SDOR4) See Appendix "Shutdown time of the PSR-TRISAFE system" on page 133.
Recovery time	< 10 s

General data	
Nominal operating mode	100% operating factor
Degree of protection in acc. with VDE 0470 Part 1	
Housings	IP20
Connection terminal blocks	IP20
Installation location	Min. IP54
Mounting type	DIN rail mounting
Mounting position	On a horizontal DIN rail
Housing design	Polyamide PA, non-reinforced, yellow
Air clearances and creepage distances between the circuits	In acc. with EN 50178
Pollution degree	2
Overvoltage category	III
Maximum power dissipation under nominal conditions	6372 mW (at a = 20, b = 2, c = 4, d = 2, e = 2, I _{Clock} = 100 mA, I _{Signal} = 100 mA, I _{Out/GND} = 2 A, I _{Out/Out} = 2 A) See Appendix "Calculating the power dissipation" on page 129
Maximum number of safe extension modules in PSR-TRISAFE system	10
Maximum number of standard extension devices (gateways) in PSR-TRISAFE system	1
Maximum continuous current via PSR-TBUS	4 A

Dimensions and weight		
	Screw connection	Spring-cage connection
Width / height / depth	67.5 mm / 114.5 mm / 99 mm	67.5 mm / 114.5 mm / 112 mm
Weight with connectors	approx. 154 g	approx. 154 g

Connection data		
	Screw connection	Spring-cage connection
Conductor cross section (solid/stranded)	0.2 mm ² ... 2.5 mm ² AWG 24 ... 12	0.2 mm ² ... 1.5 mm ² AWG 24 ... 16
Stripping length	7 mm	8 mm
Screw thread	M3	-
Tightening torque	0.5 Nm ... 0.6 Nm 5 lb In ... 7 lb In	-



UL note:

In order to comply with UL approval, use copper cables that are designed for operating temperatures > 75 °C.

PSR-TRISAFE system

Ambient conditions	
Ambient temperature	
Operation	- 20 °C ... + 55 °C (see Derating)
Storage/Transport	- 20 °C ... + 70 °C
Humidity	
Operation	75 % (on average, 85 % occasionally)
Storage/Transport	75 % (on average, 85 % occasionally)
Air pressure	
Operation	70 kPa ... 108 kPa (up to 3000 m above sea level)
Storage/Transport	66 kPa ... 108 kPa (up to 3500 m above sea level)
Maximum altitude	max. 2000 m above sea level See Appendix "Using PSR-TRISAFE modules at altitudes greater than 2000 m above sea level" on page 134
Shock	10 g $\Delta t = 11$ ms (three shocks in each space direction) 10 g $\Delta t = 16$ ms (continuous shock; 1000 shocks in each space direction)
Vibration (operation)	2g

Safety characteristic data - high demand		
	Single-channel parameterization	Two-channel parameterization
Stop category in acc. with IEC 60204	0	0
Category in acc. with EN ISO 13849-1	2	4
Performance level (PL) in acc. with EN ISO 13849-1	d	e
SILCL in acc. with EN 62061	2	3
Duration of use	240 months	240 months

Safety characteristic data for IEC 61508 - high demand		
	Single-channel parameterization	Two-channel parameterization
Device type	B	B
HFT	0	1
SIL	2	3
PFH _D	16.1 x 10 ⁻⁹ (PSR-TRISAFE-S) 17.1 x 10 ⁻⁹ (PSR-TRISAFE-M)	16.1 x 10 ⁻⁹ (PSR-TRISAFE-S) 17.1 x 10 ⁻⁹ (PSR-TRISAFE-M)
Demand	< 12 months	< 12 months
Proof test interval	240 months	240 months
Duration of use	240 months	240 months

Substitute representation as 1oo1 structure - high demand (relevant characteristics for the process industry)		
	Single-channel parameterization	Two-channel parameterization
Device type	B	B
HFT	0	0
SIL	2	3
Safe Failure Fraction (SFF)	99.81 %	99.81 %
λ _{SD}	0 FIT	0 FIT
λ _{SU}	1282 FIT	1282 FIT
λ _{DD}	459 FIT	459 FIT
λ _{DU}	3.39 FIT	3.39 FIT
λ _{Total}	1745 FIT	1745 FIT
MTBF	64.78 years (for MTTR = 8 h)	64.78 years (for MTTR = 8 h)
PFH _D	3.39 x 10 ⁻⁹	3.39 x 10 ⁻⁹

Safety characteristic data for IEC 61508 - low demand

	Single-channel parameterization	Two-channel parameterization
Device type	B	B
HFT	0	1
SIL	2	3
PFD _{avg}	2.99 x 10 ⁻⁴	2.99 x 10 ⁻⁴
Proof test interval	240 months	240 months
Duration of use	240 months	240 months

Substitute representation as 1oo1 structure - low demand (relevant characteristics for the process industry)

	Single-channel parameterization	Two-channel parameterization
Device type	B	B
HFT	0	0
SIL	2	3
Safe Failure Fraction (SFF)	99.84 %	99.84 %
λSD	0 FIT	0 FIT
λSU	1638 FIT	1638 FIT
λDD	505 FIT	505 FIT
λDU	3.39 FIT	3.39 FIT
λTotal	2146 FIT	2146 FIT
MTBF	64.36 years (for MTTR = 8 h)	64.36 years (for MTTR = 8 h)
PFD _{avg}	1.49 x 10 ⁻⁵ (for T1 = 1 year)	1.49 x 10 ⁻⁵ (for T1 = 1 year)

Safety characteristic data for EN 50156-2

SIL max. 3 (ref. IEC 61508)

Derating

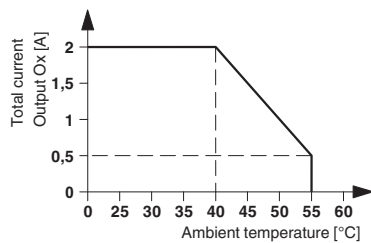



Figure 14-1 Derating curve PSR-TRISAFE-S and PSR-TRISAFE-M

14.2 Technical data of PSR-TS-SDI8-SDIO4

Logic / Supply	
Rated control circuit supply voltage U_S	24 V DC (supply via PSR-TBUS)
Permissible range	18 V DC ... 30 V DC (incl. all tolerances, incl. residual ripple)
Rated control supply current I_S	(Supply via PSR-TBUS) typ. 51.6 mA (no inputs and outputs set, A1/A2 open) typ. 66 mA (all inputs and safe outputs set)
Filter time	20 ms, typically (load-dependent, in the event of voltage dips at U_S)
Status indicator	1 x LED green 1 x LED red
Protective circuit	Yes, within scope of operating voltage limits
Safe digital inputs IO0 to IO3 (if configured) and I4 to I11	
Quantity	12 (of which 4 can be configured as input or output)
Type	digital
Input voltage range "0" signal	0 V DC to 5 V DC (for safe Off)
Input voltage range "1" signal	11 V DC ... 30 V DC
Typical current consumption at U_S	4 mA
Maximum total line length	2000 m
Fault detection time for 1-channel structure	< 1 s
Status indicator	12 x LED green
Safe digital outputs IO0 to IO3 (if configured)	
Quantity	4 (if the configurable inputs/outputs are used as outputs)
Type	digital
Nominal voltage	24 V DC (supply through A1/A2)
Permissible range	18 V DC ... 30 V DC (incl. all tolerances, incl. residual ripple)
	WARNING: Loss of safety function
	The use of unsuitable power supplies and the incorrect connection of the power supply can result in the loss of the safety function. <ul style="list-style-type: none"> • Only use power supply units with safe isolation and SELV / PELV in acc. with EN 50178 / VDE 0160. • Connect the GND connection on the output side of the power supply unit to the functional earth ground (FE) of the system.
Limiting continuous current	4 x 0.5 A (see Derating)

PSR-TRISAFE system

Safe digital outputs IO0 to IO3 (if configured)	
Load	
Capacitive ¹	max. 1 µF (electronic components)
Inductive ²	- (see "Protective circuit")
Test pulses	< 1 ms
Protective circuit	Yes, within scope of operating voltage limits
Short-circuit protection	Yes
Status indicator	4 x LED green
¹ When using electromechanical components (e.g., contactors), the capacitive load can be disregarded.	
² Connect a suitable and effective protective circuit to inductive loads.	
Clock/signal outputs TM0 and TM1	
Quantity	2
Type	digital
Nominal voltage	24 V DC (supply through A1/A2)
Limiting continuous current	50 mA
Test pulses	~ 1 ms
Short-circuit protection	Yes
Times	
Response time	Max. 30 ms (plus response time of PSR-TS-SDOR4) See Appendix "Shutdown time of the PSR-TRISAFE system" on page 133.
Recovery time	< 10 s
General data	
Nominal operating mode	100% operating factor
Degree of protection in acc. with VDE 0470 Part 1	
Housings	IP20
Connection terminal blocks	IP20
Installation location	Min. IP54
Mounting type	DIN rail mounting
Mounting position	On a horizontal DIN rail
Housing material	Polyamide PA, non-reinforced, yellow
Air clearances and creepage distances between the circuits	In acc. with EN 50178
Pollution degree	2
Overvoltage category	III
Maximum power dissipation under nominal conditions	2323 mW (at f = 8, g = 2, h = 4, I _{clock} = 50 mA, I _{Out/GND} = 500 mA) See Appendix "Calculating the power dissipation" on page 129

General data

Maximum number of safe extension modules in PSR-TRISAFE system	10
Maximum number of standard extension devices (gateways) in PSR-TRISAFE system	1
Maximum continuous current via PSR-TBUS	4 A

Dimensions and weight

	Screw connection	Spring-cage connection
Width / height / depth	22.5 mm / 99 mm / 114.5 mm	22.5 mm / 112 mm / 114.5 mm
Weight with connectors	Approx. 130 g	Approx. 130 g

Dimensions and connection data

	Screw connection	Spring-cage connection
Conductor cross section (solid/stranded)	0.2 mm ² ... 2.5 mm ² AWG 24 ... 12	0.2 mm ² ... 1.5 mm ² AWG 24 ... 16
Stripping length	7 mm	8 mm
Screw thread	M3	-
Tightening torque	0.5 Nm ... 0.6 Nm 5 lb In ... 7 lb In	-



UL note:

In order to comply with UL approval, use copper cables that are designed for operating temperatures > 75 °C.

Ambient conditions

Ambient temperature	
Operation	- 20 °C ... + 55 °C (see Derating)
Storage/Transport	- 20 °C ... + 70 °C
Humidity	
Operation	75 % (on average, 85 % occasionally)
Storage/Transport	75 % (on average, 85 % occasionally)
Air pressure	
Operation	70 kPa ... 108 kPa (up to 3000 m above sea level)
Storage/Transport	66 kPa ... 108 kPa (up to 3500 m above sea level)
Maximum altitude	max. 2000 m above sea level See Appendix "Using PSR-TRISAFE modules at altitudes greater than 2000 m above sea level" on page 134
Shock	10 g Δt = 11 ms (three shocks in each space direction) 10 g Δt = 16 ms (continuous shock; 1000 shocks in each space direction)
Vibration (operation)	2g

Safety characteristic data - high demand		
	Single-channel parameterization	Two-channel parameterization
Stop category in acc. with IEC 60204	0	0
Category in acc. with EN ISO 13849-1	2	4
Performance level (PL) in acc. with EN ISO 13849-1	d	e
SILCL in acc. with EN 62061	2	3
Duration of use	240 months	240 months

Safety characteristic data for IEC 61508 - high demand		
	Single-channel parameterization	Two-channel parameterization
Device type	B	B
HFT	0	1
SIL	2	3
PFH _D	3.94×10^{-9}	3.94×10^{-9}
Demand	< 12 months	< 12 months
Proof test interval	240 months	240 months
Duration of use	240 months	240 months

Substitute representation as 1oo1 structure - high demand (relevant characteristics for the process industry)		
	Single-channel parameterization	Two-channel parameterization
Calculation base:	For configuration of up to 8 inputs and up to 4 outputs	
Device type	B	B
HFT	0	0
SIL	2	3
Safe Failure Fraction (SFF)	99.88 %	99.88 %
λ_{SD}	0 FIT	0 FIT
λ_{SU}	1253 FIT	1253 FIT
λ_{DD}	317 FIT	317 FIT
λ_{DU}	1.91 FIT	1.91 FIT
λ_{Total}	1572 FIT	1572 FIT
MTBF	71.91 years (for MTTR = 8 h)	71.91 years (for MTTR = 8 h)
PFH _D	1.91×10^{-9}	1.91×10^{-9}

Safety characteristic data for IEC 61508 - low demand

	Single-channel parameterization	Two-channel parameterization
Device type	B	B
HFT	0	1
SIL	2	3
PFD _{avg}	2.1×10^{-4}	2.1×10^{-4}
Proof test interval	240 months	240 months
Duration of use	240 months	240 months

Substitute representation as 1oo1 structure - low demand (relevant characteristics for the process industry)

	Single-channel parameterization	Two-channel parameterization
Calculation base:	For configuration of up to 8 inputs and up to 4 outputs	
Device type	B	B
HFT	0	0
SIL	2	3
Safe Failure Fraction (SFF)	99.91 %	99.91 %
λ_{SD}	0 FIT	0 FIT
λ_{SU}	1729 FIT	1729 FIT
λ_{DD}	349 FIT	349 FIT
λ_{DU}	1.91 FIT	1.91 FIT
λ_{Total}	2080 FIT	2080 FIT
MTBF	66.41 years (for MTTR = 8 h)	66.41 years (for MTTR = 8 h)
PFD _{avg}	8.38×10^{-6} (for T1 = 1 year)	8.38×10^{-6} (for T1 = 1 year)

Safety characteristic data for EN 50156-2

SIL max. 3 (ref. IEC 61508)

Derating

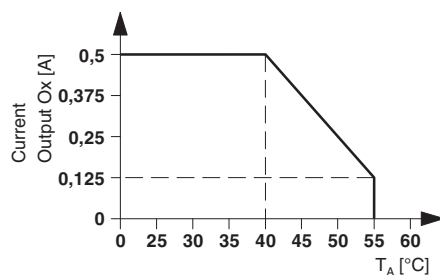

Key:

T_A = Ambient temperature

Figure 14-2 Derating curve PSR-TS-SDI8-SDIO4

14.3 Technical data of PSR-TS-SDOR4

Logic / Supply	
Rated control circuit supply voltage U_S	24 V DC (supply via PSR-TBUS)
Permissible range	18 V DC ... 30 V DC (incl. all tolerances, incl. residual ripple)
Rated control supply current I_S	(Supply via PSR-TBUS) 74 mA (at 24 V DC, relay outputs set) 54 mA (at 24 V DC, relay outputs not set)
Status indicator	1 x LED green 1 x LED red
Protective circuit	Yes, within scope of operating voltage limits
Safe relay outputs O0 to O3	
Quantity	4 (single-channel) 2 (two-channel, connected in pairs)
<div style="border: 1px solid black; padding: 5px;">  <p>In the delivery state, the relay outputs are connected in pairs. Pair 1: 13/14 and 23/24 (bridge between contacts 13/23) Pair 2: 33/34 and 43/44 (bridge between contacts 33/43)</p> </div>	
Type	Relay contacts, safety-related N/O contacts
Contact material	AgSnO ₂ (as of HW03) AgCuNi + 0.2 - 0.4 μm Au (up to HW02)
Switching voltage	Min. 12 V AC/DC (as of HW03) Min. 5 V AC/DC (up to HW02) Max. 250 V AC/DC
Limiting continuous current	4 A (see Derating)
Switching current	Min. 3 mA (as of HW03) Min. 5 mA (up to HW02)
Switching capacity	Min. 60 mW
Mechanical service life	10 x 10 ⁶ switching cycles
Output fuse	6 A gL/gG 4 A gL/gG (for low-demand applications)
Status indicator	4 x LED green
Signal outputs M0 to M3	
Quantity	4
Type	digital
Nominal voltage	24 V DC (supply through A1/A2)

Signal outputs M0 to M3	
Limiting continuous current	50 mA
Protective circuit	Yes, within scope of operating voltage limits
Short-circuit protection	Yes
Times	
Response time	Max. 50 ms See Appendix "Shutdown time of the PSR-TRISAFE system" on page 133.
Recovery time	< 10 s
General data	
Nominal operating mode	100% operating factor
Degree of protection in acc. with VDE 0470 Part 1	
Housings	IP20
Connection terminal blocks	IP20
Installation location	Min. IP54
Mounting type	DIN rail mounting
Mounting position	On a horizontal DIN rail
Housing material	Polyamide PA, non-reinforced, yellow
Air clearances and creepage distances between the circuits	In acc. with DIN EN 50178
Rated insulation voltage	250 V AC
Rated surge voltage/insulation	4 kV / basic insulation between output contact current paths (13/14, 23/24, 33/34, 43/44) 6 kV / safe isolation, reinforced insulation between output contact current paths (13/14, 23/24, 33/34, 43/44) and the other circuits
Pollution degree	2
Overvoltage category	III
Maximum power dissipation under nominal conditions	Up to 40 °C ambient temperature: 3932 mW (at m = 4, n = 4, I _{Load} = 4 A, I _{Signal} = 50 mA) Up to 55 °C ambient temperature (derating taken into account): 1532 mW (at m = 4, n = 4, I _{Load} = 1 A, I _{Signal} = 50 mA) See Appendix "Calculating the power dissipation" on page 129
Maximum number of safe extension modules in PSR-TRISAFE system	10
Maximum number of standard extension devices (gateways) in PSR-TRISAFE system	1
Maximum continuous current via PSR-TBUS	4 A

Dimensions and weight

	Screw connection	Spring-cage connection
Width / height / depth	22.5 mm / 99 mm / 114.5 mm	22.5 mm / 112 mm / 114.5 mm
Weight with connectors	Approx. 140 g	Approx. 140 g

Dimensions and connection data

	Screw connection	Spring-cage connection
Conductor cross section (solid/stranded)	0.2 mm ² ... 2.5 mm ² AWG 24 ... 12	0.2 mm ² ... 1.5 mm ² AWG 24 ... 16
Stripping length	7 mm	8 mm
Screw thread	M3	-
Tightening torque	0.5 Nm ... 0.6 Nm 5 lb In ... 7 lb In	-



UL note:

In order to comply with UL approval, use copper cables that are designed for operating temperatures > 75 °C.

Ambient conditions

Ambient temperature	
Operation	- 20 °C ... + 55 °C (see Derating)
Storage/Transport	- 20 °C ... + 70 °C
Humidity	
Operation	75 % (on average, 85 % occasionally)
Storage/Transport	75 % (on average, 85 % occasionally)
Air pressure	
Operation	70 kPa ... 108 kPa (up to 3000 m above sea level)
Storage/Transport	66 kPa ... 108 kPa (up to 3500 m above sea level)
Maximum altitude	max. 2000 m above sea level See Appendix "Using PSR-TRISAFE modules at altitudes greater than 2000 m above sea level" on page 134
Shock	10 g Δt = 11 ms (three shocks in each space direction) 10 g Δt = 16 ms (continuous shock; 1000 shocks in each space direction)
Vibration (operation)	2g

Safety characteristic data - high demand

	Single-channel parameterization		Two-channel parameterization	
	As of HW03	Up to HW02	As of HW03	Up to HW02
Stop category in acc. with IEC 60204	0	0	0	0
Category in acc. with EN ISO 13849-1	1	1	4	4
Performance level (PL) in acc. with EN ISO 13849-1	c	c	e ¹	e ¹
SILCL in acc. with EN 62061	1	1	3	3
Duration of use	240 months	240 months	240 months	240 months

¹ For applications in PL e, the required demand for the safety function is once per month.

Safety characteristic data for IEC 61508 - high demand

	Single-channel parameterization				Two-channel parameterization	
	As of HW03		Up to HW02		As of HW03	Up to HW02
HFT	0	0	0	0	1	1
SIL	1	1	1	1	3	3
PFH _D	3.67 x 10 ⁻⁷	5.5 x 10 ⁻⁷	1.41 x 10 ⁻⁷	1.0 x 10 ⁻⁷	7.3 x 10 ⁻¹⁰	7.3 x 10 ⁻¹⁰
	(4 A DC13; 8760 switching cycles/year)	(5 A AC15; 8760 switching cycles/year)	(5 A DC13; 8760 switching cycles/year)	(3 A AC15; 8760 switching cycles/year)	(4 A DC13; 5 A AC15; 8760 switching cycles/year)	(5 A DC13; 3 A AC15; 8760 switching cycles/year)
Demand	< 12 months	< 12 months	< 12 months	< 12 months	< 12 months	< 12 months
Proof test interval	240 months	240 months	240 months	240 months	240 months	240 months
Duration of use	240 months	240 months	240 months	240 months	240 months	240 months

Substitute representation as 1oo1 structure - high demand (relevant characteristics for the process industry)

	Single-channel parameterization		Two-channel parameterization	
	As of HW03	Up to HW02	As of HW03	Up to HW02
Calculated at	4 A DC13	5 A DC13	4 A DC13	5 A DC13
HFT	0	0	0	0
SIL	1	1	3	3
Safe Failure Fraction (SFF)	83.79 %	93.88 %	99.99 %	99.99 %
λSD	873 FIT	873 FIT	910 FIT	910 FIT
λSU	990 FIT	1259 FIT	2681 FIT	1781 FIT
λDD	33 FIT	33 FIT	23.75 FIT	21.51 FIT
λDU	367 FIT	141 FIT	0.17 FIT	0.13 FIT
λTotal	2263 FIT	2305 FIT	3615 FIT	2712 FIT
MTBF	49.94 years (for MTTR = 8 h)	49.02 years (for MTTR = 8 h)	31.26 years (for MTTR = 8 h)	41.67 years (for MTTR = 8 h)
PFH _D	3.67 x 10 ⁻⁷	1.41 x 10 ⁻⁷	1.72 x 10 ⁻¹⁰	1.27 x 10 ⁻¹⁰

Safety characteristic data for IEC 61508 - low demand

	Single-channel parameterization		Two-channel parameterization	
	As of HW03	Up to HW02	As of HW03	Up to HW02
HFT	0	0	1	1
SIL	1	1	3	3
PFD _{avg}	4.35 x 10 ⁻³	4.35 x 10 ⁻³	1.18 x 10 ⁻⁴	1.18 x 10 ⁻⁴
Proof test interval	60 months	60 months	60 months	60 months
Duration of use	240 months	240 months	240 months	240 months

Substitute representation as 1oo1 structure - low demand (relevant characteristics for the process industry)

	Single-channel parameterization		Two-channel parameterization	
	As of HW03	Up to HW02	As of HW03	Up to HW02
HFT	0	0	0	0
SIL	1	1	3	3
Safe Failure Fraction (SFF)	94.26 %	94.26 %	99.88 %	99.88 %
λSD	873 FIT	873 FIT	910 FIT	910 FIT
λSU	2379FIT	2379FIT	3700 FIT	3700 FIT
λDD	32 FIT	32 FIT	21.18 FIT	21.18 FIT
λDU	200 FIT	200 FIT	5.45 FIT	5.45 FIT
λTotal	3484 FIT	3484 FIT	4637 FIT	4637 FIT
MTBF	32.44 years	32.44 years	24.37 years	24.37 years
	(for MTTR = 8 h)	(for MTTR = 8 h)	(for MTTR = 8 h)	(for MTTR = 8 h)
PFD _{avg}	9.69 x 10 ⁻⁴	9.69 x 10 ⁻⁴	1.23 x 10 ⁻⁴	1.23 x 10 ⁻⁴
	(for T1 = 1 year)	(for T1 = 1 year)	(for T1 = 1 year)	(for T1 = 1 year)

Safety characteristic data for EN 50156-2

SIL max. 3 (ref. IEC 61508)

Derating

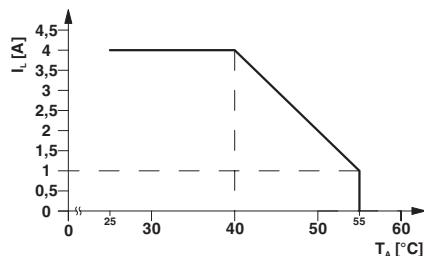

Figure 14-3 Derating curve PSR-TS-SDOR4

Key:

T_A = Ambient temperature

I_L = Current for output O_x



Up to an ambient temperature of 40 °C, each contact can be loaded with 4 A.
 At an ambient temperature of 55 °C, each contact can be loaded with 1 A, two contacts with 1.4 A or one contact with 2 A.

14.4 Approvals



For the current approvals, please visit phoenixcontact.net/products.

14.5 Conformance with EMC Directive

Conformance with EMC Directive 2014/30/EU

Noise immunity test in acc. with DIN EN 61000-6-2

Electrostatic discharge (ESD)	EN 61000-4-2 (IEC 61000-4-2)	Criterion B 4 kV contact discharge, 8 kV air discharge
Electromagnetic fields	EN 61000-4-3 (IEC 61000-4-3)	Criterion A, field strength 10 V/m
Fast transients (burst)	EN 61000-4-4 (IEC 61000-4-4)	Criterion B, test voltage 2 kV
Transient overvoltage (surge)	EN 61000-4-5 (IEC 61000-4-5)	Criterion B DC supply lines: 1 kV (asymmetrical) Signal lines: 1 kV (asymmetrical)
Conducted disturbance variables	EN 61000-4-6 (IEC 61000-4-6)	Criterion A, test voltage 10 V

Noise emission test in acc. with DIN EN 61000-6-4

Noise emission	EN 55016-1-2 EN 55016-2-1 EN 55016-2-3	Class A Industrial
----------------	--	--------------------

14.6 System requirements of the configuration software SAFECONF

Software requirements	
Supported operating systems	Windows 8 (32-bit or 64-bit) Windows 7 (32-bit or 64-bit) SP1 Windows XP SP3 Windows 10 (from SAFECONF V 2.9.2)
Supported browser	Internet Explorer Version 6 or later
Hardware requirements	
CPU	Pentium 2 GHz (recommended)/1 GHz (minimum)
RAM	Windows 7/Windows 8 2 GB (recommended)/1 GB (minimum) Windows XP 1 GB (recommended)/512 MB (minimum)
Hard disk	At least 250 MB available hard disk space
Drive	CDROM
Operating panels	Keyboard, mouse
Monitor resolution	At least 800 x 600
Miscellaneous	
Basic functions	Configuration of the PSR-TRISAFE safety modules
Supported languages	German, English, Spanish, French, Italian

14.7 Ordering data

14.7.1 PSR-TRISAFE modules

Description	Type	Order No.	Pcs./Pkt.
Safety modules			
Configurable safety module, non-extendable , DIN rail connector is included			
Module with screw connections	PSR-SCP-24DC/TS/S	2986229	1
Module with spring-cage connections	PSR-SPP-24DC/TS/S	2986232	1
Configurable safety module, extendable , DIN rail connector is included			
Module with screw connections	PSR-SCP-24DC/TS/M	2986012	1
Module with spring-cage connections	PSR-SPP-24DC/TS/M	2986025	1
Safe extension module			
Configurable safe extension module with parameterizable inputs/outputs , DIN rail connector is included			
Module with screw connections	PSR-SCP-24DC/TS/SDI8/SDIO4	2986038	1
Module with spring-cage connections	PSR-SPP-24DC/TS/SDI8/SDIO4	2986041	1
Configurable safe extension module with relay outputs , DIN rail connector is included			
Module with screw connections	PSR-SCP-24DC/TS/SDOR4/4x1	2986096	1
Module with spring-cage connections	PSR-SPP-24DC/TS/SDOR4/4x1	2986106	1

14.7.2 Software



Make sure you always use the latest software.

The software can be downloaded free of charge at phoenixcontact.net/products.

Description	Type	Order No.
Configuration software for SafetyBridge Technology and PSR-TRISAFE modules, connecting cable for PSR-TRISAFE	SAFECONF	2986119
IFS-CONF-SUITE-INTERFACE Setup (FTD Container: IFS-CONF + INTERFACE SYSTEM DTMs + INTERFACE ANALOG DTMs + USB driver)	IFS-CONF-SUITE-INTERFACE_1vxx.zip	See download area of the gateway used

14.7.3 Accessories

Description	Type	Order No.	Pcs./Pkt.
PSR configuration package including SAFECONF configuration software, configuration cable (USB) and quick start guide			
German	PSR-SAFECONF-BOX-DE	2986151	1
English	PSR-SAFECONF-BOX-EN	2986164	1
Memory module for PSR-TRISAFE-S and PSR-TRISAFE system (supplied as standard with the safety module)	IFS-CONFSTICK	2986122	1
USB connecting cable , USB plug type A to USB plug type Mini-B; length: 3 m	CABLE-USB/MINI-USB-3.0M	2986135	1
USB connection cable , communication between industrial PC and Phoenix Contact devices with the 12-pos. IFS data port	IFS-USB-DATACABLE	2320500	1
Copy and delete station for IFS-CONFSTICK memory modules	COPYSTATION-IFS	2901985	1
Filter terminal block for filtering test pulses of safe semiconductor outputs, as well as for EMC filtering			
Adjustable filter values: 1.5 µF/11.5 µF	PSR-FTB/1.5/11.5	2904476	1
Adjustable filter values: 20 µF/86 µF	PSR-FTB/20/86	2904477	1
DIN rail connector for safety relay modules, for supplying/controlling/monitoring (depending on the module)	PSR-TBUS	2890425	1
DIN rail connector for connection to electronics housings	ME 22.5 TBUS 1.5/ 5-ST-3.81 GN	2707437	1

14.7.4 Gateways



The following gateways are suitable for use with the PSR-TRISAFE system.

Description	Bus system	Type	Order No.	Pcs./Pkt.
Gateway for the connection of up to 32 INTERFACE system devices to a higher-level controller, DIN rail connector is included	CANopen®	EM-CAN-GATEWAY-IFS	2901504	1
Gateway for the connection of up to 32 INTERFACE system devices to a higher-level controller, DIN rail connector is included	Modbus/TCP	EM-MODBUS-GATEWAY-IFS	2901528	1
Gateway for the connection of up to 32 INTERFACE system devices to a higher-level controller, DIN rail connector is included	DeviceNet™	EM-DNET-GATEWAY-IFS	2901529	1
Gateway for the connection of up to 32 INTERFACE system devices to a higher-level controller, DIN rail connector is included	EtherNet/IP™	EM-ETH-GATEWAY-IFS	2901988	1
Gateway for the connection of up to 32 INTERFACE system devices to a higher-level controller, DIN rail connector is included	PROFINET	EM-PNET-GATEWAY-IFS	2904472	1
Gateway for the connection of up to 32 INTERFACE system devices to a higher-level controller, DIN rail connector is included	PROFIBUS DP	EM-PB-GATEWAY-IFS	2297620	1
Gateway for the connection of up to 32 INTERFACE system devices to a higher-level controller, DIN rail connector is included	Modbus/RS-232	EM-RS232-GATEWAY-IFS	2901526	1
Gateway for the connection of up to 32 INTERFACE system devices to a higher-level controller, DIN rail connector is included	Modbus/RS-485	EM-RS485-GATEWAY-IFS	2901527	1

14.8 Documentation



Make sure you always use the latest documentation.

This is available on the Internet at phoenixcontact.net/products for download.

A Technical appendix

A 1 Calculating the power dissipation

The total power dissipation of a PSR-TRISAFE system depends on the power dissipation of the logic, the power dissipation per connected input and per clock or signal output used, as well as the power dissipation per output used.

If you use the PSR-TRISAFE-M safety module in combination with extension devices, the power dissipation of all connected extension devices adds up additionally.

Use the following formulas to calculate the total power dissipation. The contact resistances of the connection terminal blocks are neglected in these calculations.

A 1.1 Power dissipation for PSR-TRISAFE-M and PSR-TRISAFE-S

Power dissipation of the logic

– at $U_{S(24\text{ V}/0\text{ V})} = U_{S(A1/A2)} = 24\text{ V DC}$

$$P_{\text{Logic}} = P_{24\text{ V}/0\text{ V}} + P_{A1/A2} = 310\text{ mW} + 770\text{ mW} = 1080\text{ mW}$$

Power dissipation per connected input

– at $U_{S(24\text{ V}/0\text{ V})} = 24\text{ V DC}$

$$P_{\text{Input}} = 134\text{ mW}$$

Power dissipation per clock output

– at $U_{S(A1/A2)} = 24\text{ V DC}$

$$P_{\text{Clock}} = I_{\text{Clock}}^2 * 60\text{ m}\Omega$$

Power dissipation per signal output

– at $U_{S(A1/A2)} = 24\text{ V DC}$

$$P_{\text{Signal}} = I_{\text{Signal}}^2 * 60\text{ m}\Omega$$

Power dissipation per Out/GND output

– at $U_{S(24\text{ V}/0\text{ V})} = 24\text{ V DC}$

$$P_{\text{Out/GND}} = I_{\text{Out/GND}}^2 * 138\text{ m}\Omega$$

Power dissipation per Out/Out output

– at $U_{S(24\text{ V}/0\text{ V})} = 24\text{ V DC}$

$$P_{\text{Out/Out}} = I_{\text{Out/Out}}^2 * 188\text{ m}\Omega$$

Total power dissipation

$$P_{\text{Total}} = P_{\text{Logic}} + a * P_{\text{Input}} + b * P_{\text{Clock}} + c * P_{\text{Signal}} + d * P_{\text{Out/GND}} + e * P_{\text{Out/Out}} + P_{\text{Extensions}}$$

therefore

$$P_{\text{Total}} = 1080 \text{ mW} + a * 134 \text{ mW} + b * I_{\text{Clock}}^2 * 60 \text{ m}\Omega + c * I_{\text{Signal}}^2 * 60 \text{ m}\Omega + d * I_{\text{Out/GND}}^2 * 138 \text{ m}\Omega + e * I_{\text{Out/Out}}^2 * 188 \text{ m}\Omega + P_{\text{Extensions}}$$

Key:

P	Power dissipation in mW
U_S	Rated control circuit supply voltage U _S assigned to the connections
I_{Clock}	Current drawn at a clock output
I_{Signal}	Current drawn at a signal output
I_{Out/GND}	Current drawn at an output with GND reference point for the load
I_{Out/Out}	Current drawn at an output with OUT reference point for the load
a	Number of inputs used
b	Number of clock outputs used
c	Number of signal outputs used
d	Number of outputs used with GND reference point for the load
e	Number of outputs used with OUT reference point for the load
P_{Extensions}	Total power consumption of the extension devices at U _{S(24 V/0 V)} from the TBUS (only relevant with PSR-TRISAFE-M)

A 1.2 Power dissipation for PSR-TS-SDI8-SDIO4

Power dissipation of the logic

– at $U_{S(24\text{ V}/0\text{ V})} = U_{S(A1/A2)} = 24\text{ V DC}$ (via PSR-TBUS)

$$P_{\text{Logic}} = P_{24\text{ V}/0\text{ V}} + P_{A1/A2} = 450\text{ mW} + 77\text{ mW} = 617\text{ mW}$$

Power dissipation per connected input

– at $U_{S(A1/A2)} = 24\text{ V DC}$

$$P_{\text{Input}} = 134\text{ mW}$$

Power dissipation per clock/signal output

– at $U_{S(24\text{ V}/0\text{ V})} = 24\text{ V DC}$

$$P_{\text{Clock}} = I_{\text{Clock}}^2 * 350\text{ m}\Omega$$

Power dissipation per Out/GND output

– at $U_{S(A1/A2)} = 24\text{ V DC}$

$$P_{\text{Out/GND}} = I_{\text{Out/GND}}^2 * 96\text{ m}\Omega + 134\text{ mW}$$

Total power dissipation

$$P_{\text{Total}} = P_{\text{Logic}} + f * P_{\text{Input}} + g * P_{\text{Clock}} + h * P_{\text{Out/GND}}$$

therefore

$$P_{\text{Total}} = 617\text{ mW} + f * 134\text{ mW} + g * I_{\text{Clock}}^2 * 350\text{ m}\Omega + h * (I_{\text{Out/GND}}^2 * 96\text{ m}\Omega + 134\text{ mW})$$

Key:

P	Power dissipation in mW
U_S	Rated control circuit supply voltage U _S assigned to the connections
I_{Clock}	Current drawn at a clock output
I_{Out/GND}	Current drawn at an output with GND reference point
f	Number of inputs used
g	Number of clock/signal outputs used
h	Number of outputs used with GND reference point

A 1.3 Power dissipation for PSR-TS-SDOR4

Power dissipation of the logic

– at $U_{S(24\text{ V}/0\text{ V})} = U_{S(A1/A2)} = 24\text{ V DC}$ (via PSR-TBUS)

$$P_{\text{Logic}} = P_{24\text{ V}/0\text{ V}} + P_{A1/A2} = 480\text{ mW} + 30\text{ mW} = 510\text{ mW}$$

Power dissipation per signal output

– at $U_{S(A1/A2)} = 24\text{ V DC}$

$$P_{\text{Signal}} = I_{\text{Signal}}^2 * 100\text{ m}\Omega$$

Power dissipation per relay output

– at $U_{S(24\text{ V}/0\text{ V})} = 24\text{ V DC}$

$$P_{\text{Load1}} = 55\text{ mW}$$

Power dissipation per relay output

– at $U_{X3/X4} = 24\text{ V DC}$

$$P_{\text{Load2}} = I_{\text{Load}} * 200\text{ mV}$$

Total power dissipation

$$P_{\text{Total}} = P_{\text{Logic}} + m * P_{\text{Signal}} + n * (P_{\text{Load1}} + P_{\text{Load2}})$$

therefore

$$P_{\text{Total}} = 510\text{ mW} + I_{\text{Signal}}^2 * 100\text{ m}\Omega + n * (55\text{ mW} + I_{\text{Load}} * 200\text{ mV})$$

Key:

P	Power dissipation in mW
U_S	Rated control circuit supply voltage US assigned to the connections
I_{Signal}	Current drawn at a signal output
I_{Load}	Load current that is switched at the relay output
m	Number of signal outputs used
n	Number of relay outputs used

A 2 Shutdown time of the PSR-TRISAFE system

Required shutdown time

The required shutdown time is determined based on your safety application.

Actual shutdown time

The actual shutdown time for the safety function always has to be shorter than the required shutdown time.

You can determine the actual shutdown time for the safety function (t_{SF}) by means of the following formula:

$$t_{SF} = t_S + t_{TRISAFE} (+ t_{SDOR}) + t_A + t_{STOP}$$

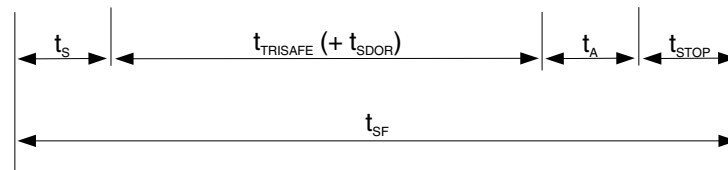

Figure A-1 Shutdown time for the safety function

Key:

t_S	Response time of the sensor/signal transmitter
$t_{TRISAFE}$	Maximum response time of the PSR-TRISAFE system
t_{SDOR}	Maximum response time of the PSR-TS-SDOR4 module
t_A	Response time of the actuator
t_{STOP}	Stopping time of the machine

Maximum response time



The maximum response time ($t_{TRISAFE}$) guaranteed by the PSR-TRISAFE system is 30 ms. The maximum response time $t_{TRISAFE}$ applies independent of the number of safe extension modules used. The PSR-TS-SDOR4 relay module is excepted from this.

When one or more relay modules are used, the maximum response time of the PSR-TS-SDOR4 module (t_{SDOR}) has to be added once. This is due to the mechanical release time of the relay. The maximum response time t_{SDOR} is 50 ms.

A 3 Using PSR-TRISAFE modules at altitudes greater than 2000 m above sea level

The following section describes the conditions for using modules of the PSR-TRISAFE system at altitudes greater than 2000 above sea level.



Observe the relevant data (technical data, derating, etc.) that is specific to the module being used.
See "Technical data and ordering data" on page 107.

Use of the module at altitudes **greater than 2000 m above sea level up to 4500 m above sea level** is possible under the following conditions:

Maximum ambient temperature

1. Determine the maximum ambient temperature for operation with the corresponding factor in accordance with the table below.

Derating curve

2. If derating is specified, offset all the points of the derating curve by the corresponding factor in accordance with the table below.

Altitude above sea level	Temperature derating factor
2000 m	1
2500 m	0.953
3000 m	0.906
3500 m	0.859
4000 m	0.813
4500 m	0.766

Switching voltage of relay outputs

3. Limit the maximum switching voltage for relay outputs in accordance with the table below. Observe the technical data for the device.

Maximum switching voltage according to the technical data for the device	Maximum switching voltage when used at altitudes greater than 2000 m above sea level
< 150 V AC/DC	Maximum switching voltage according to the technical data for the device still valid
> 150 V AC/DC	Limited to max. 150 V AC/DC

A 3.1 Example calculation



The following calculation and the derating curve shown are an example for using a PSR-TRISAFE module at an altitude of 3000 m above sea level.
Perform the actual calculation and offset the derating curve for the module used in acc. with the technical data and the “Derating” section.

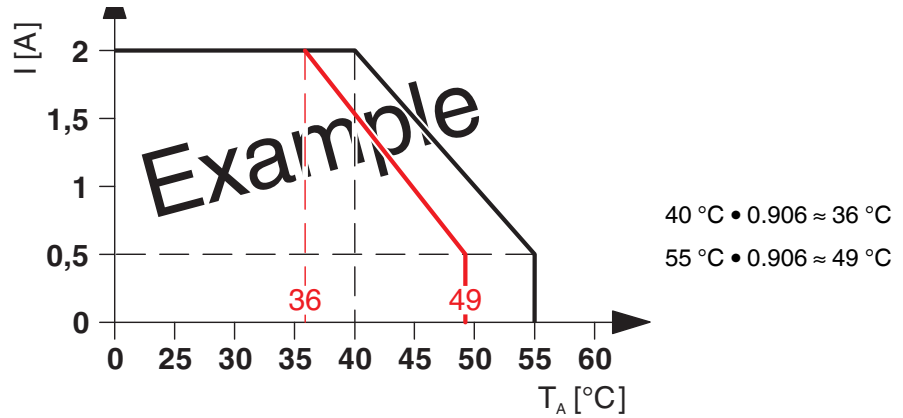

Figure A-2 Example of a suspended derating curve (red)

B Appendix for document lists

B 1 List of figures

Section 2

Figure 2-1:	Example structure of a safety system with PSR-TRISAFE-M	15
Figure 2-2:	Safety module extension PSR-TRISAFE-M	17

Section 3

Figure 3-1:	Screw terminal blocks (left) and spring-cage terminal blocks (right) ...	24
Figure 3-2:	Block diagram PSR-TRISAFE-S	24
Figure 3-3:	Block diagram PSR-TRISAFE-M	24
Figure 3-4:	Possible operating modes (status) of PSR-TRISAFE-S/-M	26
Figure 3-5:	Operating and indication elements of PSR-TRISAFE-S/-M	27
Figure 3-6:	Status bar in the SAFECONF safe configuration software (safety module already contains a configuration project)	29
Figure 3-7:	IFS-CONFSTICK with PSR-TRISAFE safety module	30
Figure 3-8:	PSR-TRISAFE-S/-M signal connections	31

Section 4

Figure 4-1:	Screw terminal blocks (left) and spring-cage terminal blocks (right) ...	37
Figure 4-2:	Block diagram for PSR-TS-SDI8-SDIO4	38
Figure 4-3:	Diagnostics and status indicators PSR-TS-SDI8-SDIO4	38
Figure 4-4:	Signal connections of PSR-TS-SDI8-SDIO4	39

Section 5

Figure 5-1:	Screw terminal blocks (left) and spring-cage terminal blocks (right) ...	43
Figure 5-2:	Block diagram for PSR-TS-SDOR4	44
Figure 5-3:	Diagnostics and status indicators PSR-TS-SDOR4	45
Figure 5-4:	Signal connections of PSR-TS-SDOR4	46

Section 6

Figure 6-1:	Single-channel assignment of inputs	51
Figure 6-2:	Single-channel assignment of inputs: external supply	52
Figure 6-3:	Single-channel assignment of inputs: external supply (OSSD)	53
Figure 6-4:	Two-channel equivalent assignment of inputs, supply through T0 and T1 (both clocked)	54
Figure 6-5:	Two-channel equivalent assignment of inputs, external supply, cross-circuit monitoring disabled	55
Figure 6-6:	Two-channel equivalent assignment of inputs, external supply (OSSD)	56
Figure 6-7:	Two-channel non-equivalent assignment of inputs, supply through T0 and T1, cross-circuit monitoring enabled	57
Figure 6-8:	Two-channel non-equivalent assignment of inputs, external supply ...	58
Figure 6-9:	Example of the freewheeling circuit for an external relay	59
Figure 6-10:	Single-channel assignment of outputs	60
Figure 6-11:	Two-channel assignment of outputs	61
Figure 6-12:	Example of the freewheeling circuit for an external relay	62
Figure 6-13:	Single-channel assignment of relay outputs	62
Figure 6-14:	Two-channel assignment of relay outputs	63

Section 7

Figure 7-1:	Mounting DIN rail connectors	67
Figure 7-2:	Snapping a PSR-TRISAFE module onto the DIN rail	68
Figure 7-3:	Connection to screw terminal blocks	69
Figure 7-4:	Connection to spring-cage terminal blocks	69
Figure 7-5:	Connecting the PSR-TRISAFE-S/-M supply voltage	73
Figure 7-6:	Connecting supply voltage: PSR-TS-SDI8-SDIO4 and PSR-TS-SDOR4	74
Figure 7-7:	Power supply of the PSR-TRISAFE system	75

Section 9

Figure 9-1:	Accessing the help in the SAFECONF configuration software	80
-------------	---	----

Section 10

Figure 10-1:	Flow chart: Example for configuration and startup (1 of 3)	81
Figure 10-2:	Flow chart: example for configuration and startup (2 of 3)	82
Figure 10-3:	Flow chart: example for configuration and startup (3 of 3)	83
Figure 10-4:	USB connection between PC and safety module	85
Figure 10-5:	Dialog box following successful data transmission	86
Figure 10-6:	Confirming the configuration with the “Confirm” button	86
Figure 10-7:	Inserting the IFS-CONFSTICK	89
Figure 10-8:	Example of a function test for the safety system using the online mode of SAFECONF	92

Section 14

Figure 14-1:	Derating curve PSR-TRISAFE-S and PSR-TRISAFE-M	112
Figure 14-2:	Derating curve PSR-TS-SDI8-SDIO4	117
Figure 14-3:	Derating curve PSR-TS-SDOR4	123

Appendix A

Figure A-1:	Shutdown time for the safety function	135
Figure A-2:	Example of a suspended derating curve (red)	137

B 2 List of tables

Section 3

Table 3-1:	LED diagnostics indicators of the PSR-TRISAFE-S/-M.....	27
Table 3-2:	Module behavior without IFS-CONFSTICK.....	30

Section 4

Table 4-1:	LED diagnostics indicators of the PSR-TS-SDI8-SDIO4.....	38
------------	--	----

Section 5

Table 5-1:	Insulation coordination.....	44
Table 5-2:	LED diagnostics indicators of the PSR-TS-SDOR4	45
Table 5-3:	Relay outputs.....	46
Table 5-4:	Assignment of relay outputs.....	47

Section 7

Table 7-1:	Important assembly instructions	66
------------	---------------------------------------	----

Section 11

Table 11-1:	Diagnostic indicators for PSR-TRISAFE-S and PSR-TRISAFE-M	94
Table 11-2:	Status indicators for safe inputs and outputs for PSR-TRISAFE-S and PSR-TRISAFE-M	96
Table 11-3:	Diagnostic indicators for PSR-TS-SDI8-SDIO4	97
Table 11-4:	Status indicators for safe inputs and outputs for PSR-TS-SDI8-SDIO4.....	97
Table 11-5:	Diagnostic indicators for PSR-TS-SDOR4	98
Table 11-6:	Status indicators of the safe outputs for PSR-TS-SDOR4.....	98

Section 12

Table 12-1:	Solutions for general problems	99
Table 12-2:	Solutions for problems with the graphical connection editor	99
Table 12-3:	Solutions for problems with the parameterization editor.....	100
Table 12-4:	Solutions for communication problems between SAFECNF and the safety module	101
Table 12-5:	Solutions for communication problems between the safety module and the safe extension module	103
Table 12-6:	Solutions for messages from the safety module.....	103

B 3 Index

A

Accessories	127
Application examples	
Application examples for blocks	18
Approvals	124
Assembly	66
Performing	67
Assembly instructions	66

B

Basic insulation	44
Block diagram	
PSR-TRISAFE-M.....	24
PSR-TRISAFE-S	24
PSR-TS-SDI8-SDIO4	38
PSR-TS-SDOR4.....	44

C

Cable lengths to sensors/control devices.....	70
Check values (CRC)	87
Checking and downloading the project	81
Checking the project	82
Clock outputs	
PSR-TRISAFE-M.....	33
PSR-TRISAFE-S	33
Clock/signal outputs	
PSR-TS-SDI8-SDIO4	40
Communication	
USB.....	16
Configuration.....	81
Configuration download	88
Confirm button	19, 27, 28, 82, 85, 86, 89
Conformance with EMC directive	124
Connection.....	69
PSR-TRISAFE system example	75
Connection editor.....	81, 91, 99
Connection terminal blocks	23, 37, 43
COPYSTATION-IFS.....	88
Creating a project.....	81
Cross-circuit monitoring	
Disabled	52, 55, 58
Enabled.....	51, 54, 57
Cross-circuit protection	32

D

Decommissioning.....	105
Defining the bus configuration.....	81
Device Parameterization Editor.....	100
Diagnostic and status indicators	
PSR-TRISAFE-M.....	27
PSR-TRISAFE-S	27
Diagnostic indicators	
PSR-TRISAFE-M.....	94
PSR-TRISAFE-S	94
PSR-TS-SDI8-SDIO4	97
PSR-TS-SDOR4.....	98
Diagnostic tools.....	22
Diagnostics	93
Gateways	22, 93
LED indicators at the module.....	93
SAFECONF	22, 93
Diagnostics and status indicators	
PSR-TS-SDI8-SDIO4	38
PSR-TS-SDOR4.....	45
DIN rail	67
DIN rail connector	16, 67
Connection	66
Directives	13
Disposal	105
Documentation.....	14, 129

E

Electrical installation.....	65, 69
Electrical safety	11
Electrostatic discharge	11
EMC directive.....	124
Error detection	10, 21
Error state	21
ESD.....	11
Expert mode (EASYSIM simulation).....	83
Extension	
Safe extension.....	25
Standard extension	25
Extension devices	
Maximum number.....	66
Mounting direction	66

F

Firmware update 77
Forcing 28, 83
Forcing of signals 28
Freewheeling circuit 59, 62
Function test 83, 87, 91
Functional blocks/functions, safe 8
Functions/functional blocks, safe 8

G

Gateways 128
Ground contact 11
Ground switching outputs
 PSR-TRISAFE-M..... 34
 PSR-TRISAFE-S 34

H

Hardware editor 81, 91
Help online 18
Hotline..... 14
Housings..... 10

I

IFS-CONFSTICK 16, 28, 30, 84
 Behavior with no IFS-CONFSTICK..... 88
 Configuration download..... 88
 Removing 88
Installation..... 65
Installation space 11
Insulation coordination 44
Insulation rating..... 11
Intended use 8
Interface USB..... 16

L

LED symbols..... 93

M

Maintenance 105
Method of operation of PSR-TRISAFE safety system . 15
Mounting 65
Mounting location..... 66
Mounting position..... 11

O

Online help..... 18
Online mode of SAFECONF 90, 91
Online mode, SAFECONF 82
Operating and indication elements
 PSR-TRISAFE-M..... 27
 PSR-TRISAFE-S 27
Ordering data 107, 126
OSSD
 Single-channel 53
 Two-channel..... 56

P

Parameterizing inputs/outputs..... 81
Password protection 22, 90
PELV 11
Personnel, requirements 9
Power dissipation 131
Power supply of the PSR-TRISAFE sytem 75
Power supply units 11
Problems and solutions 99
Product description
 PSR-TRISAFE-M..... 23
 PSR-TRISAFE-S 23
 PSR-TS-SDI8-SDIO4 37
 PSR-TS-SDOR4..... 43
Project documentation 83
Project download 88
Project startup 85, 86
Protective circuit..... 59, 62
PSR DIN rail connector 16
PSR-TBUS..... 16, 67
PSR-TRISAFE safety system
 System overview 15
 Using the system 18
PSR-TRISAFE system connection example 75

Q

Qualification of personnel..... 9
Qualified personnel 9, 65, 81

R

Reference ground 75
Reinforced insulation 44
Relay outputs, safe 46

Removal.....	65, 68
Repair	105
Requirements for personnel.....	9
Response time	135
Restart inhibit	13, 20
Revision history.....	149

S

Safe extension module	
PSR-TS-SDI8-SDIO4	37
PSR-TS-SDOR4.....	43
Safe inputs	
PSR-TRISAFE-M.....	31
PSR-TRISAFE-S	31
PSR-TS-SDI8-SDIO4	39
Safe isolation	44
Safe outputs	
PSR-TRISAFE-M.....	32
PSR-TRISAFE-S	32
PSR-TS-SDI8-SDIO4	40
Safe relay outputs	46
Safe state	19
SAFECONF	8
Checking and downloading the project.....	85
Diagnostics.....	22
Installing the software	79
Online mode	90, 91
Starting up a project	85, 86
Status bar	29, 85, 90
System requirements	125
SAFECONF configuration software.....	79
SAFECONF diagnostics	93
Safety concept	12
Safety functions, possible	18
Safety hotline	14
Safety module	
PSR-TRISAFE-M.....	23
PSR-TRISAFE-S	23
Safety notes	
Electrical.....	11
General	9
Screw connections.....	23, 37, 43
Screw terminal block	
Connection	69
Shutdown time	135

Signal connections	
PSR-TRISAFE-M.....	31
PSR-TRISAFE-S	31
PSR-TS-SDI8-SDIO4	39
PSR-TS-SDOR4.....	46
Signal outputs	
PSR-TRISAFE-M.....	33
PSR-TRISAFE-S	33
PSR-TS-SDOR4.....	48
Signal redundancy	70
Simulation	82
Software.....	126
Software system requirements.....	125
Solutions to problems.....	99
Spring connections	23, 37, 43
Spring-cage connections	23, 37, 43
Spring-cage terminal blocks.....	69
Standards	13
Startup	81
Startup inhibit	13, 20, 82, 87, 89
Startup mode	83, 90
Startup/restart behavior.....	13, 19
Status bar of SAFECONF	29, 85, 90
Status bar, SAFECONF	82
Status indicators	
PSR-TRISAFE-M.....	96
PSR-TRISAFE-S	96
PSR-TS-SDI8-SDIO4	97
PSR-TS-SDOR4.....	98
Supply connections	
PSR-TRISAFE-M.....	34
PSR-TRISAFE-S	34
PSR-TS-SDI8-SDIO4	42
PSR-TS-SDOR4.....	48
Supply voltage	
Connection	72
Switching on.....	72
System description PSR-TRISAFE	15
T	
TBUS	16, 67
Technical data.....	107
PSR-TRISAFE-M.....	107
PSR-TRISAFE-S	107
PSR-TS-SDI8-SDIO4	113
PSR-TS-SDOR4.....	118

PSR-TRISAFE system

Test pulses.....	32
Top-hat rail.....	67

U

Updating the firmware	77
Uploading configuration	90
Uploading project.....	90
USB communication	16
USB interface.....	16, 28, 84, 88
Use, intended.....	8

C Revision history

Revision	Date	Contents
02	2017-12-08	First publication of the English version

Please observe the following notes

General terms and conditions of use for technical documentation

Phoenix Contact reserves the right to alter, correct, and/or improve the technical documentation and the products described in the technical documentation at its own discretion and without giving prior notice, insofar as this is reasonable for the user. The same applies to any technical changes that serve the purpose of technical progress.

The receipt of technical documentation (in particular user documentation) does not constitute any further duty on the part of Phoenix Contact to furnish information on modifications to products and/or technical documentation. You are responsible to verify the suitability and intended use of the products in your specific application, in particular with regard to observing the applicable standards and regulations. All information made available in the technical data is supplied without any accompanying guarantee, whether expressly mentioned, implied or tacitly assumed.

In general, the provisions of the current standard Terms and Conditions of Phoenix Contact apply exclusively, in particular as concerns any warranty liability.

This manual, including all illustrations contained herein, is copyright protected. Any changes to the contents or the publication of extracts of this document is prohibited.

Phoenix Contact reserves the right to register its own intellectual property rights for the product identifications of Phoenix Contact products that are used here. Registration of such intellectual property rights by third parties is prohibited.

Other product identifications may be afforded legal protection, even where they may not be indicated as such.

How to contact us

Internet

Up-to-date information on Phoenix Contact products and our Terms and Conditions can be found on the Internet at:

phoenixcontact.com

Make sure you always use the latest documentation.

It can be downloaded at:

phoenixcontact.net/products

Subsidiaries

If there are any problems that cannot be solved using the documentation, please contact your Phoenix Contact subsidiary.

Subsidiary contact information is available at phoenixcontact.com.

Published by

PHOENIX CONTACT GmbH & Co. KG

Flachmarktstraße 8

32825 Blomberg

GERMANY

Should you have any suggestions or recommendations for improvement of the contents and layout of our manuals, please send your comments to:

tecdoc@phoenixcontact.com