

User manual

## **UM EN IB IL 24 PSDI 16-PAC**

Inline module with 16 safe digital inputs

# User manual

## Inline module with 16 safe digital inputs

2013-02-27

---

Designation: UM EN IB IL 24 PSDI 16-PAC

Revision: 01

Order No.: 2992145

This user manual is valid for:

Designation	Revision	Order No.
IB IL 24 PSDI 16-PAC	HW/FW: 00/100	2700994

---

## Please observe the following notes

### User group of this manual

The use of products described in this manual is oriented exclusively to:

- Qualified electricians or persons instructed by them, who are familiar with applicable standards and other regulations regarding electrical engineering and, in particular, the relevant safety concepts.
- Qualified application programmers and software engineers, who are familiar with the safety concepts of automation technology and applicable standards.

### Explanation of symbols used and signal words



This is the safety alert symbol. It is used to alert you to potential personal injury hazards. Obey all safety measures that follow this symbol to avoid possible injury or death.

There are three different categories of personal injury that are indicated with a signal word.

**DANGER** This indicates a hazardous situation which, if not avoided, will result in death or serious injury.

**WARNING** This indicates a hazardous situation which, if not avoided, could result in death or serious injury.

**CAUTION** This indicates a hazardous situation which, if not avoided, could result in minor or moderate injury.



This symbol together with the signal word **NOTE** and the accompanying text alert the reader to a situation which may cause damage or malfunction to the device, hardware/software, or surrounding property.



This symbol and the accompanying text provide the reader with additional information or refer to detailed sources of information.

### How to contact us

#### Internet

Up-to-date information on Phoenix Contact products and our Terms and Conditions can be found on the Internet at:

[www.phoenixcontact.com](http://www.phoenixcontact.com)

Make sure you always use the latest documentation.

It can be downloaded at:

[www.phoenixcontact.net/products](http://www.phoenixcontact.net/products)

#### Subsidiaries

If there are any problems that cannot be solved using the documentation, please contact your Phoenix Contact subsidiary.

Subsidiary contact information is available at [www.phoenixcontact.com](http://www.phoenixcontact.com).

#### Published by

PHOENIX CONTACT GmbH & Co. KG  
Flachsmarktstraße 8  
32825 Blomberg  
GERMANY

Should you have any suggestions or recommendations for improvement of the contents and layout of our manuals, please send your comments to:

[tecdoc@phoenixcontact.com](mailto:tecdoc@phoenixcontact.com)

**Please observe the following notes**

---

**General terms and conditions of use for technical documentation**

Phoenix Contact reserves the right to alter, correct, and/or improve the technical documentation and the products described in the technical documentation at its own discretion and without giving prior notice, insofar as this is reasonable for the user. The same applies to any technical changes that serve the purpose of technical progress.

The receipt of technical documentation (in particular user documentation) does not constitute any further duty on the part of Phoenix Contact to furnish information on modifications to products and/or technical documentation. You are responsible to verify the suitability and intended use of the products in your specific application, in particular with regard to observing the applicable standards and regulations. All information made available in the technical data is supplied without any accompanying guarantee, whether expressly mentioned, implied or tacitly assumed.

In general, the provisions of the current standard Terms and Conditions of Phoenix Contact apply exclusively, in particular as concerns any warranty liability.

This manual, including all illustrations contained herein, is copyright protected. Any changes to the contents or the publication of extracts of this document is prohibited.

Phoenix Contact reserves the right to register its own intellectual property rights for the product identifications of Phoenix Contact products that are used here. Registration of such intellectual property rights by third parties is prohibited.

Other product identifications may be afforded legal protection, even where they may not be indicated as such.

# Table of contents

1	For your safety .....	1-1
1.1	General safety notes.....	1-1
1.2	Electrical safety .....	1-3
1.3	Safety of the machine or system.....	1-4
1.4	Directives and standards .....	1-5
1.5	Correct usage.....	1-5
1.6	Documentation .....	1-6
1.7	Abbreviations used .....	1-8
1.8	Safety hotline.....	1-8
2	Product description .....	2-1
2.1	Brief description of the safety module.....	2-1
2.2	Structure of the safety module .....	2-2
2.3	Housing dimensions .....	2-3
2.4	Safe digital inputs and clock outputs UT1 and UT2 .....	2-4
2.4.1	Safe digital inputs .....	2-4
2.4.2	Clock outputs UT1 and UT2 .....	2-6
2.5	Connection options for sensors depending on the parameterization .....	2-7
2.6	Local diagnostic and status indicators .....	2-8
2.7	Safe state .....	2-10
2.7.1	Operating state .....	2-10
2.7.2	Error detection in I/O devices .....	2-10
2.7.3	Device errors .....	2-11
2.7.4	Parameterization errors .....	2-11
2.8	Process data words .....	2-12
2.8.1	SafetyBridge .....	2-12
2.8.2	PROFIsafe (PROFIBUS, PROFINET) .....	2-12
2.9	Programming data/configuration data.....	2-13
2.9.1	Local bus (INTERBUS) .....	2-13
2.9.2	Other bus systems (PROFIBUS, PROFINET, etc.) .....	2-13
3	Inline potential and data routing, and Inline plugs .....	3-1
3.1	Inline potential and data routing.....	3-1
3.2	Supply voltage $U_L$ .....	3-1
3.3	Supply voltage $U_M$ .....	3-1
3.4	Terminal point assignment.....	3-3
4	Assembly, removal, and electrical installation .....	4-1
4.1	Assembly and removal .....	4-1
4.1.1	Unpacking the module .....	4-1
4.1.2	General .....	4-1

4.1.3	Setting the DIP switches .....	4-2
4.1.4	Assembly and removal of the safety module .....	4-3
4.2	Electrical installation .....	4-5
4.2.1	Electrical installation of the Inline station .....	4-5
4.2.2	Electrical installation of the safety module .....	4-5
5	Parameterization of the safety module .....	5-1
5.1	Parameterization in a SafetyBridge system .....	5-1
5.2	Parameterization in a PROFIsafe system .....	5-2
5.3	Parameterization of the safe inputs.....	5-3
5.4	Parameterization of clock outputs UT1 and UT2 .....	5-6
6	Duration of a safety demand .....	6-1
6.1	SafetyBridge.....	6-1
6.2	PROFIsafe.....	6-1
7	Connection examples for safe inputs .....	7-1
7.1	Explanation of the examples.....	7-1
7.2	Measures required to achieve a specific safety integrity level .....	7-3
7.3	Single-channel assignment of safe inputs .....	7-5
7.3.1	Single-channel with cross-circuit monitoring .....	7-6
7.3.2	Single-channel: supply through UT1 without cross-circuit monitoring ..	7-8
7.3.3	Single-channel: supply through OSSD .....	7-10
7.4	Two-channel equivalent assignment of safe inputs .....	7-13
7.4.1	Notes about errors for two-channel equivalent assignment of safe inputs 7-14	
7.4.2	Two-channel equivalent cross-circuit monitoring enabled: supply through UT1 and UT2 .....	7-15
7.4.3	Two-channel equivalent cross-circuit monitoring disabled: supply through a clock output or external supply .....	7-18
7.4.4	Two-channel equivalent: external supply (OSSD) .....	7-21
7.5	Two-channel non-equivalent assignment of safe inputs .....	7-23
7.5.1	Notes about errors for two-channel non-equivalent assignment of safe in- puts .....	7-24
7.5.2	Two-channel non-equivalent with cross-circuit monitoring: supply through UT1 and UT2 .....	7-25
7.5.3	Two-channel non-equivalent cross-circuit monitoring disabled: supply through a clock output or external supply .....	7-28
8	Startup and validation .....	8-1
8.1	Initial startup .....	8-1
8.2	Restart after replacing a safety module .....	8-3
8.2.1	Replacing a safety module .....	8-3

---

	8.2.2 Restart .....	8-3
	8.3 Validation.....	8-3
<b>9</b>	<b>Errors: messages and removal .....</b>	<b>9-1</b>
	9.1 Safe digital input errors.....	9-3
	9.2 Clock output UT1 and UT2 errors .....	9-5
	9.3 Supply voltage errors.....	9-5
	9.4 Parameterization errors .....	9-6
	9.5 General errors .....	9-7
	9.6 PROFIsafe errors.....	9-7
	9.7 Acknowledging an error.....	9-8
	9.7.1 Acknowledging an error for SafetyBridge .....	9-8
	9.7.2 Acknowledging an error for PROFIsafe .....	9-9
<b>10</b>	<b>Maintenance, repair, decommissioning, and disposal .....</b>	<b>10-1</b>
	10.1 Maintenance.....	10-1
	10.2 Repair.....	10-1
	10.3 Decommissioning and disposal.....	10-1
<b>1</b>	<b>Technical data and ordering data .....</b>	<b>1-1</b>
	1.1 System data .....	1-1
	1.1.1 SafetyBridge .....	1-1
	1.1.2 PROFIsafe .....	1-1
	1.2 IB IL 24 PSDI 16-PAC.....	1-2
	1.3 Conformance with EMC Directive.....	1-6
	1.4 Ordering data .....	1-6
	1.4.1 Ordering data: safety module .....	1-6
	1.4.2 Ordering data: documentation .....	1-7
<b>A</b>	<b>Appendix: PROFIsafe terms used in the manual .....</b>	<b>A-1</b>
<b>B</b>	<b>Appendix: F-Parameters and iParameters .....</b>	<b>B-1</b>
	B 1 F-Parameters.....	B-1
	B 2 iParameters .....	B-2
	B 3 Diagnostic messages for parameter errors.....	B-3
	B 3.1 Diagnostic messages for F-Parameters and iParameters for PROFIsafe . B-3	
	B 3.2 Diagnostic messages for parameter errors for SafetyBridge .....	B-4

<b>C</b>	Appendix: checklists .....	<b>C-1</b>
	C 1 Planning .....	C-2
	C 2 Assembly and electrical installation .....	C-4
	C 3 Startup and parameterization .....	C-5
	C 4 Validation .....	C-6
<b>D</b>	Appendix: revision history .....	<b>D-1</b>



# 1 For your safety

## Purpose of this manual

The information in this document is designed to familiarize you with how the IB IL 24 PSDI 16-PAC safety module works, its operating and connection elements, and its parameter settings. This information will enable you to use the IB IL 24 PSDI 16-PAC module within a SafetyBridge or PROFIsafe system according to your requirements.

## Validity of the user manual

This manual is only valid for the IB IL 24 PSDI 16-PAC module in the version indicated on the inner cover page.

## 1.1 General safety notes



**WARNING: Depending on the application, incorrect handling of the safety module can pose serious risks for the user**

When working with the safety module within the SafetyBridge or PROFIsafe system, please observe all the safety notes included in this section.

### Requirements

Knowledge of the following is required:

- The non-safety-related target system (e.g., INTERBUS, PROFIBUS, PROFINET)
- The SafetyBridge or PROFIsafe system
- The components used in your application
- The Inline product range
- Operation of the software tools used
- Safety regulations in the field of application

### Qualified personnel

In the context of the use of the SafetyBridge or PROFIsafe system, the following operations may only be carried out by qualified personnel:

- Planning
- Configuration, parameterization, programming
- Installation, startup, servicing
- Maintenance, decommissioning

This user manual is, therefore, aimed at:

- Qualified personnel who plan and design safety equipment for machines and systems and are familiar with regulations governing safety in the workplace and accident prevention.
- Qualified personnel who install and operate safety equipment in machines and systems.

In terms of the safety notes in this manual, qualified personnel are persons who, because of their education, experience and instruction, and their knowledge of relevant standards, regulations, accident prevention, and service conditions, have been authorized to carry out any required operations, and who are able to recognize and avoid any possible dangers.

### Documentation

You must observe all information in this manual as well as in the documents listed in Section “Documentation” on page 1-6.

**Safety of personnel and equipment**

The safety of personnel and equipment can only be assured if the safety module is used correctly (see Section "Correct usage" on page 1-5).

**Error detection**

Depending on the wiring and the corresponding setting of the safe input module parameters, the SafetyBridge or PROFIsafe system can detect various errors within the safety equipment.

**Do not carry out any repairs**

Repair work may not be carried out on the safety module.

In the event that an error cannot be removed, please contact Phoenix Contact immediately, engage a service engineer or send the faulty module directly to Phoenix Contact.

**Do not open the housing/security seal**

It is strictly prohibited to open the safety module housing. In order to prevent the manipulation of the safety module and to detect the unauthorized opening of the safety module, a security seal is applied to the module. This security seal is damaged in the event of unauthorized opening. In this case, the correct operation of the safety module can no longer be ensured.

**Measures to prevent incorrect connection and polarity reversal**

Take measures to prevent the incorrect connection, polarity reversal, and manipulation of connections.

## 1.2 Electrical safety

**WARNING: Hazardous shock currents and the loss of functional safety**

Disregarding instructions for electrical safety may result in hazardous shock currents and the loss of functional safety.

In order to ensure electrical safety, please observe the following points.

**Direct/indirect contact**

Protection against direct and indirect contact according to VDE 0100 Part 410 must be ensured for all components connected to the system. In the event of an error, parasitic voltages must not occur (single-fault tolerance).

This can be achieved by:

- Using power supply units with safe isolation (PELV).
- Decoupling circuits, which are not PELV systems, using optocouplers, relays, and other components, which meet the requirements of safe isolation.

**Power supply units for 24 V supply**

Only use power supply units with safe isolation and PELV according to EN 50178/VDE 0160 (PELV). This prevents short circuits between primary and secondary sides.

Make sure that the output voltage of the power supply does not exceed 32 V even in the event of an error.

**Insulation rating**

When selecting the operating equipment, please take into consideration the contamination and surge voltages, which may occur during operation.

The IB IL 24 PSDI 16-PAC module is designed for surge voltage category II (according to DIN EN 60664-1). If you expect surge voltages in the system, which exceed the values defined in surge voltage category II, take into consideration additional measures for voltage limitation.

**Installation and configuration**

Please observe the instructions for installing and configuring the system (see Section “Documentation” on page 1-6).

**WARNING: Depending on the application, incorrect installation and upgrades can pose serious risks for the user**

The user is obliged to design the devices used and their installation in the system according to these requirements. This also means that existing plants and systems retrofitted with SafetyBridge or PROFIsafe must be checked and tested again in this respect.

### 1.3 Safety of the machine or system

The machine/system manufacturer and the operator are solely responsible for the safety of the machine or system and the implemented application, in which the machine or system is used. The Machinery Directive must therefore be observed.

**Draw up and implement a safety concept**

In order to use the safety module described in this document, you must have drawn up an appropriate safety concept for your machine or system. This includes a hazard and risk analysis according to the directives and standards specified in Section "Directives and standards" on page 1-5, as well as a test report (checklist) for validating the safety function (see "Appendix: checklists" on page C-1).



SafetyBridge: please refer to the documentation for the configurable safety module used.

The target safety integrity level (SIL according to EN 61508, SIL CL according to EN 62061 or performance level and category according to EN ISO 13849-1) is ascertained on the basis of the risk analysis. The safety integrity level ascertained determines how to connect and parameterize the safety module within the overall safety function.

Within the SafetyBridge or PROFIsafe system, the safety module can be used to achieve safety functions with the following requirements depending on the conditions of use:

- Up to SIL 3 according to standard EN 61508
- Up to SIL CL 3 according to standard EN 62061
- Up to Cat. 4/PL e according to standard EN ISO 13849-1

**Check hardware and parameterization**

Carry out a **validation** every time you make a safety-related modification to your overall system.

Use your test report to ensure that:

- The safe devices are connected to the correct safe sensors and actuators
- The safe input and output channels have been parameterized correctly
- The variables have been linked to the safe sensors and actuators correctly (single-channel or two-channel)

---

## 1.4 Directives and standards

The manufacturers and operators of machines and systems, in which the IB IL 24 PSDI 16-PAC module is used, are responsible for adhering to all applicable directives and legislation.

For the standards observed by the module, please refer to the certificate issued by the approval body and the EC declaration of conformity. These documents are available on the Internet at [www.phoenixcontact.net/products](http://www.phoenixcontact.net/products).

## 1.5 Correct usage

Only use the SafetyBridge or PROFIsafe system in accordance with the instructions in this section.

The IB IL 24 PSDI 16-PAC safety module is designed exclusively for use in a SafetyBridge or PROFIsafe system.

It can only perform its safety-related tasks within the system if it has been integrated into the execution process correctly and in such a way as to avoid errors.

You must observe all information in this manual as well as in the documents listed in “Documentation” on page 1-6. In particular, only use the module according to the technical data and ambient conditions specified in Section 1, “Technical data and ordering data” on page 1-1 and onwards.

Within the SafetyBridge or PROFIsafe system, the safety module can be used to achieve safety functions with the following requirements depending on the conditions of use:

- Up to SIL 3 according to standard EN 61508
- Up to SIL CL 3 according to standard EN 62061
- Up to Cat. 4/PL e according to standard EN ISO 13849-1

It is designed for connecting single-channel or two-channel sensors, which can be used in association with safety technology.

For example, the module can be used in the following applications:

- Single or two-channel emergency stop or safety door equipment
- Applications with enable button
- Applications with two-hand control devices
- Applications with mode selector switches
- As secondary switchgear for safety-related photoelectric barriers
- Safety circuits according to EN 60204 Part 1

## 1.6 Documentation

### Latest documentation

Make sure you always use the latest documentation. Changes or additions to this document can be found on the Internet at [www.phoenixcontact.net/products](http://www.phoenixcontact.net/products).

### SafetyBridge

When working on the SafetyBridge system and its components, you must always keep this user manual and other items of product documentation to hand and observe the information therein.

User manuals:

- For the controller used
- For SafetyBridge system I/O modules
- For SafetyBridge system function blocks

Please also observe the relevant information about the bus system used.

### PROFIsafe

When working on the PROFIsafe system and its components, you must always keep this user manual and other items of product documentation to hand and observe the information therein.

UM QS EN IB IL 24 PSDX - S7

Configuring Inline modules with safe inputs or outputs under PROFIsafe on a SIMATIC® S7 controller

User manuals:

- For the safe controller used
- For PROFIsafe I/O modules
- For PROFIsafe function blocks

Please also observe the relevant information about PROFIBUS, PROFINET, and PROFIsafe, which is available on the Internet at [www.profisafe.net](http://www.profisafe.net).

**Standard INTERBUS**

When working on the INTERBUS system and its components, you must always keep the listed user manuals and other items of product documentation to hand and observe the information therein.

IBS SYS INTRO G4 UM E

General introduction to the INTERBUS system

IBS SYS PRO INST UM E

Configuring and installing INTERBUS

IBS SYS DIAG DSC UM E

INTERBUS Diagnostics Guide for Generation 4 controller boards

UM QS EN CONFIG+ and/or Config+ online help

Quick start guide and/or online help for the Config+ software

UM QS EN PC WORX or online help

Quick start guide and/or online help for the PC Worx software

IBS SYS FW G4 UM E

Firmware services and error messages

**Inline product range**

IL SYS INST UM E

Automation terminals of the Inline product range (configuration and installation)

IB IL SYS PRO UM E

Configuring and installing the INTERBUS Inline product range

Documentation for the bus coupler used

## 1.7 Abbreviations used

Table 1-1 Abbreviations used

Abbreviation	Meaning	Standard	Example
SIL	Safety integrity level	EN 61508	SIL 2, SIL 3
SIL CL	SIL claim limit	EN 62061	SIL CL 3
Cat.	Category	EN ISO 13849-1	Cat. 2, Cat. 4
PL	Performance level	EN ISO 13849-1	PL e, PL d

Table 1-2 Abbreviations used

Abbreviation	Meaning
PELV	Protective extra-low voltage according to EN 611316-2
EUC	Equipment under control
OSSD	<p>OSSD</p> <p>Output signal switching device</p> <p>OSSD is the part of electrosensitive protective equipment, which is connected to the machine control system and switches off if the sensor part responds during correct operation.</p>



For terms and abbreviations used for PROFI-safe, please refer to “Appendix: PROFI-safe terms used in the manual” on page A-1.

## 1.8 Safety hotline

Should you have any technical questions, please contact our 24-hour hotline.

Phone: + 49 5281 9-462777

E-mail: [safety-service@phoenixcontact.com](mailto:safety-service@phoenixcontact.com)



## 2 Product description

### 2.1 Brief description of the safety module

The IB IL 24 PSDI 16-PAC module is an input module, which is designed for use within an Inline station.

The IB IL 24 PSDI 16-PAC safety module can be used as part of an Inline station at any point within a SafetyBridge or PROFIsafe system.

The transmission speed and the operating mode (SafetyBridge or PROFIsafe) are set via the 2-pos. DIP switch.

One transmission speed must be used consistently in an **INTERBUS system**.

One transmission speed must be used consistently in the relevant Inline station in a **SafetyBridge or PROFIsafe system**.

The module has a 10-pos. DIP switch, which is used to set the SafetyBridge or PROFIsafe address.

The module has eight safe digital inputs for two-channel assignment or sixteen safe digital inputs for single-channel assignment.

The inputs can be parameterized according to the application and enable the integration of sensors in SafetyBridge or PROFIsafe systems.

Within a SafetyBridge or PROFIsafe system, the IB IL 24 PSDI 16-PAC safety module can be used to achieve safety functions with the following requirements:

- Up to SIL 3 according to standard EN 61508
- Up to SIL CL 3 according to standard EN 62061
- Up to Cat. 4/PL e according to standard EN ISO 13849-1

## 2.2 Structure of the safety module

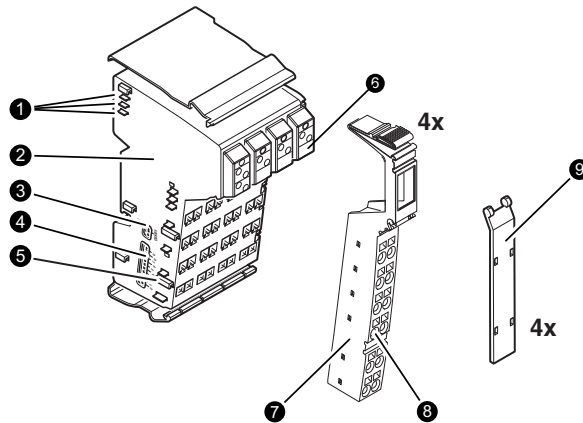

Figure 2-1 Structure of the safety module

- 1 Data jumpers (local bus)
- 2 Electronics base with labeling including hardware/firmware version designation (not shown)
- 3 Switch for setting the transmission speed and operating mode
- 4 Switch for setting the address



For more detailed information on setting the switches, please refer to Section “Setting the DIP switches” on page 4-2.

- 5 Potential jumpers
- 6 Diagnostic and status indicators; for assignment and meaning see Section “Local diagnostic and status indicators” on page 2-8
- 7 Inline plug; for assignment see Section “Terminal point assignment” on page 3-3
- 8 Terminal points
- 9 Marking field

### 2.3 Housing dimensions

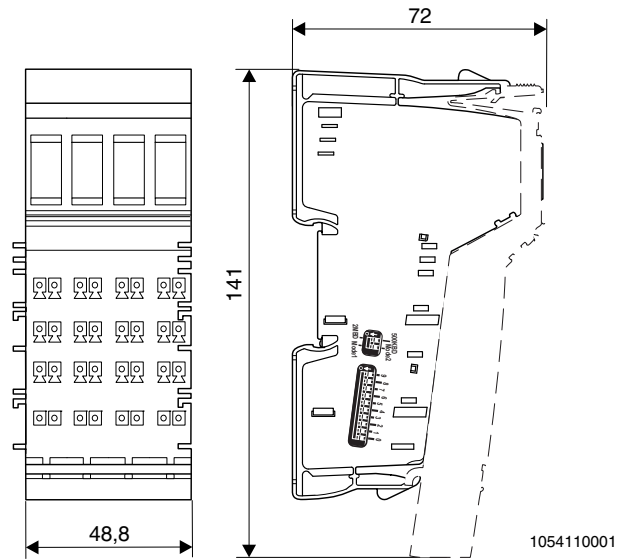

Figure 2-2 Housing dimensions (in mm)

## 2.4 Safe digital inputs and clock outputs UT1 and UT2

### 2.4.1 Safe digital inputs

The safety module has eight safe digital inputs for two-channel assignment or sixteen safe digital inputs for single-channel assignment. The supply voltage for the inputs can be provided externally or via the clock outputs.

#### Technical data

For the technical data for the safe inputs, please refer to page 1-4.

#### Parameterization

The individual safe digital inputs of a safety module can be parameterized differently. This means that the inputs can be adapted to various operating conditions and different safety integrity levels can be implemented (SIL, SIL CL, Cat., PL).



The safety integrity level (SIL, SIL CL, Cat., PL) and error detection that can be achieved depend on the parameterization, the structure of the sensor, and the cable installation (see “Connection examples for safe inputs” on page 7-1).

For information on the parameterization of the inputs, please refer to Section “Parameterization of the safe inputs” on page 5-3.

#### Diagnostics

Diagnostics are provided via both the local diagnostic indicators and the diagnostic messages, which are transmitted to the safe controller (PROFIsafe) or to a configurable safety module (SafetyBridge).

For information on the diagnostic messages of the inputs, please refer to Section “Safe digital input errors” on page 9-3.



**CAUTION: Diagnostic data is not safety-related**

Do not use the diagnostic data to execute safety-related functions or actions.

**Requirements for controlling devices/sensors**

The error detection of the module varies depending on the parameterization. This results in specific requirements for the sensors.

- To acquire input signals, the signal duration must be greater than the parameterized filter time.
- The sensors must be suitable for the application.  
Only use appropriately qualified sensors (suitable for the required category, SIL, SIL CL, PL).
- Use switches with a positive opening contact according to IEC 60947-5-1. Part 5 of this standard includes a description of the specific requirements for control switches with a positive opening contact. All positive opening control switches, which meet these specific requirements, are marked with the following symbol:



- Use reliable components. These include, for example:
  - Mechanical position switches with personal protection function with positive opening contact according to EN 60947-5-1
  - Cam-operated switches with positive opening contact
  - Emergency stop buttons/cable-operated switches with positive opening contact according to EN 60947-5-1
- Controlling devices can be evaluated on a single-channel or two-channel connection depending on the application.
- Under certain circumstances, switches (e.g., for position monitoring) must be designed redundantly depending on the risk.
- In order to achieve Cat. 3/Cat. 4, SIL 3/SIL CL 3 or PL d or e, controlling devices must usually be designed redundantly.
- Please observe any special environmental requirements in your application when selecting the controlling devices.
- Please observe the applicable C standards in your application (e.g., EN 1010), in which, for example, the number of controlling devices required to achieve a particular category is specified.

## 2.4.2 Clock outputs UT1 and UT2

The module has two independent clock outputs. They provide the supply voltage for the safe inputs. Each of these clock outputs can provide a pulse pattern to detect cross circuits and short circuits in the external wiring of the inputs.



The clock outputs are also switched on and monitored when not parameterized. If a short circuit occurs at a clock output when it is in this state, the clock output is switched off. This is indicated by the local diagnostic LED.

To exit the error, parameterize the device and acknowledge the error message.

### Technical data

For the technical data for the clock outputs, please refer to page 1-5.

### Behavior in the event of an error

In the event of short circuit to GND or overload, the affected clock output is switched off. At the same time, the error is indicated at the UT1 and/or UT2 LEDs and a diagnostic message is generated at the safe controller (PROFI-safe) or at a configurable safety module (SafetyBridge). This error must be acknowledged so that the system can be started up again following error removal.

### Error detection

Error detection depends on the parameterization. If cross-circuit detection is activated for an input pair, the relevant inputs are permanently assigned to clock outputs UT1 and UT2.

### Diagnostics

Diagnostics are provided via both the local diagnostic indicators and the diagnostic messages, which are transmitted to the safe controller (PROFI-safe) or to a configurable safety module (SafetyBridge).

For information on the diagnostic messages of the clock outputs, please refer to Section "Clock output UT1 and UT2 errors" on page 9-5.



#### **CAUTION: Diagnostic data is not safety-related**

Do not use the diagnostic data to execute safety-related functions or actions.

## 2.5 Connection options for sensors depending on the parameterization

Sensors that meet various safety requirements depending on the parameterization can be connected to the inputs. For connection examples, please refer to Section 7, "Connection examples for safe inputs".

The maximum achievable SIL/SIL CL/Cat./PL is specified in the table.

In order to achieve this:

- Observe the information in the connection examples (see Section 7, "Connection examples for safe inputs")
- Observe the requirements of the standards with regard to the external wiring and the sensors to be used to achieve a SIL/SIL CL/Cat./PL (see "Measures required to achieve a specific safety integrity level" on page 7-3)

Connection to the Inline plugs	Input							
	Single-channel sensor or redundant sensor			Two-channel redundant controlling device/sensor				
Input signal				Equivalent			Non-equivalent	
Cross-circuit monitoring	With	Without		With	Without		With	Without
Sensors that can be connected:								
– Contact-based	Yes	Yes		Yes	Yes		Yes	Yes
– With OSSD outputs			Yes			Yes		
Achievable SIL/SIL CL/Cat./PL	SIL 2 SIL CL 2 Cat. 3* PL d	SIL 2 SIL CL 2 Cat. 2 PL d	SIL 2 SIL CL 2 Cat. 2 PL d	SIL 3 SIL CL 3 Cat. 4 PL e	SIL 3 SIL CL 3 Cat. 3 PL d	SIL 3 SIL CL 3 Cat. 4** PL e	SIL 3 SIL CL 3 Cat. 4 PL e	SIL 3 SIL CL 3 Cat. 3 PL d
For connection example, see page	7-6	7-8	7-10	7-15	7-18	7-21	7-25	7-28

Key:

\* Cat. 3 can only be achieved with a redundant sensor.

\*\* The category that can be achieved depends on the sensor used.

**Cross-circuit monitoring**

The clocking for cross-circuit monitoring is provided when clock outputs UT1 and UT2 are parameterized accordingly. If all inputs are parameterized without cross-circuit monitoring, a DC voltage can be tapped at the clock outputs without clock pulses. As soon as cross-circuit monitoring has been parameterized for at least one input pair, pulses are output at clock outputs UT1 and UT2.

For inputs that are parameterized with cross-circuit monitoring, the assignment is as follows:

Inputs for channel 1 (INx\_CH1) are assigned to clock output UT1

Inputs for channel 2 (INx\_CH2) are assigned to clock output UT2

For information on error detection according to clocking, please refer to Section “Clock outputs UT1 and UT2” on page 2-6.

**Error detection**

For information on the special features of error detection, please refer to the connection examples.

## 2.6 Local diagnostic and status indicators

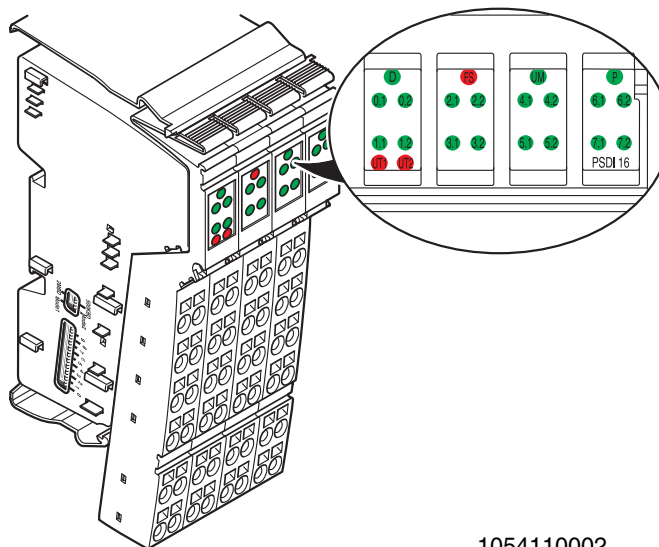



1054110002

Figure 2-3 Local diagnostic and status indicators on the IB IL 24 PSDI 16-PAC module



Table 2-1 Local diagnostic and status indicators

<b>D</b>	Green LED	Diagnostics
	OFF:	Communications power not present
	Flashing at 0.5 Hz:	Communications power present, local bus not active
	Flashing at 4 Hz:	Communications power present, error at the interface between previous and flashing terminal (the terminals after the flashing terminal cannot be addressed). (E.g., loose contact at the bus interface, terminal before the flashing terminal has failed, another terminal was snapped on during operation (not permitted))
	 Observe the module startup time of approximately 30 s. During this time the D LED flashes at 4 Hz and the bus cannot be started up.	
	ON:	Communications power present, local bus active
<b>FS</b>	Red LED	Failure state
	Flashing at 1 Hz:	Device not parameterized or parameterization was not accepted
	ON:	Hardware fault; communication to safe controller (PROFIsafe) or configurable safety module (SafetyBridge) disabled
<b>UM</b>	Green LED	Monitoring the supply voltage $U_M$
	OFF:	Communications power not present
	Flashing at 1 Hz:	$U_M$ below the permissible voltage range (undervoltage)
	ON:	$U_M$ present
<b>P</b>	Green LED	Status indicator for safe communication
	OFF:	No safe communication
	Flashing at 0.5 Hz:	Safe communication running, the controller requests operator acknowledgment
	ON:	Safe communication running without errors
<b>UT1, UT2</b>	Red LED	Diagnostic message (error) for each clock output
	OFF:	No error
	Flashing at 1 Hz:	Cross circuit of an input with external signals
	ON:	Short circuit or overload of the clock output
	 The clock output is switched off until the acknowledgment is received by the safety module (see also Section "Clock output UT1 and UT2 errors" on page 9-5).	
<b>IN 0.1 - 7.2</b>	Green LED	Status of each input (see "Terminal point assignment" on page 3-3)
	ON:	Input at logic 1
	OFF:	Input at logic 0
	 Even when the module is not parameterized, the physical state at the inputs is indicated. However, substitute value "0" is transmitted to the safe controller.	

## 2.7 Safe state

The safe state for the module is the transmission of the value equal to “0” in the image of the inputs to the safe controller (PROFIsafe) or the configurable safety module (SafetyBridge).



PROFIsafe:  
 The safe state for the F-Input data is “0”.  
 The safe state is entered by means of passivation (see “Passivation” on page A-2).

The safe state can be entered in the following cases:

1. Operating state
2. Error detection in I/O devices
3. Device errors
4. Parameterization errors

### 2.7.1 Operating state

In the operating state, the inputs can enter states “1” or “0”. In general, state “0” is the safe state. An exception is a non-equivalent parameterized input. For channel 2 of this input, “1” is the safe state, “0” is represented in the process data image of the two-channel input.

Table 2-2 Operating state depending on the state of the inputs

Type of input	Operating state equals 1 in input state	Operating state equals 0 (safe state)
Single-channel	High (1)	Low (0)
Two-channel equivalent	High/High (1/1)	High/Low (1/0) Low/High (0/1) Low/Low (0/0)
Two-channel non-equivalent	High/Low (1/0)	Low/High (0/1) Low/Low (0/0) High/High (1/1)



Please observe the state transitions (see Section “Symmetry/ start inhibit” on page 5-4).

### 2.7.2 Error detection in I/O devices

#### Inputs

If an error is detected at an input, the safe state is set at this input and a “0” is represented in the process image of the input (“0” = safe state).

Depending on the parameterization, the following errors can be detected at inputs:

- Cross circuit
- Symmetry errors
- Implausible signal change

The relevant diagnostic message is transmitted to the safe controller (PROFIsafe) or the configurable safety module (SafetyBridge) (see Section “Safe digital input errors” on page 9-3). For information on which errors are detected and when, please refer to Section “Connection examples for safe inputs” on page 7-1.

### 2.7.3 Device errors

Device errors can lead to safe communication being set.

#### Inputs

If a hardware fault in the internal circuit is detected at an input, **all** module inputs enter the safe state and "0" values are represented in the process image of the inputs ("0" = safe state).

The relevant diagnostic message is transmitted to the safe controller (PROFIsafe) or the configurable safety module (SafetyBridge) (see Section "Safe digital input errors" on page 9-3).

#### Serious errors

All serious errors that can result in the loss of or adversely affect the safety function cause the entire module to enter the safe state. The FS LED on the safety module is permanently on.

##### The following errors result in the safe state:

- Serious hardware faults in the internal circuit
- User errors
- Module overload
- Module overheating
- Incorrect supply

The relevant diagnostic message is transmitted to the safe controller (PROFIsafe) or the configurable safety module (SafetyBridge) (see Section "Errors: messages and removal" on page 9-1).

**WARNING: Loss of the safety function due to sequential errors**

In the event of a device error, the following measures should be taken to prevent sequential errors:

Disconnect the module from the power supply and replace it.

### 2.7.4 Parameterization errors

The FS LED on the safety module flashes. Parameterization errors are indicated

- As long as the module is not parameterized

or

- In the event of faulty parameterization

Parameterization errors cause the entire module to enter the safe state.

In the event of faulty parameterization, the relevant diagnostic message is transmitted to the safe controller (PROFIsafe) or the configurable safety module (SafetyBridge) (see Section "Parameterization errors" on page 9-6).

## 2.8 Process data words

### 2.8.1 SafetyBridge

The module occupies four words in the Inline system. For information on how these words are mapped, please refer to the documentation for the configurable logic module used.

The input data can only be used for the standard control system. To access the input signals, use SafetyBridge function blocks from Phoenix Contact.

In the following tables, both the maximum single-channel and maximum two-channel assignment are illustrated. Depending on the parameterization, other process data word assignments are also possible.

#### Assignment of inputs to the process data input word in the standard control system

(Word.bit) view	Word	Word 1							
	Bit	7	6	5	4	3	2	1	0
(Byte.bit) view	Byte	Byte 3							
	Bit	7	6	5	4	3	2	1	0
Module	Input (single-channel)	IN3 _Ch2	IN3 _Ch1	IN2 _Ch2	IN2 _Ch1	IN1 _Ch2	IN1 _Ch1	IN0 _Ch2	IN0 _Ch1
	Input (two-channel)	0	IN0 _Ch 1&2	0	IN0 _Ch 1&2	0	IN0 _Ch 1&2	0	IN0 _Ch 1&2

(Word.bit) view	Word	Word 1							
	Bit	15	14	13	12	11	10	9	8
(Byte.bit) view	Byte	Byte 2							
	Bit	7	6	5	4	3	2	1	0
Module	Input (single-channel)	IN7 _Ch2	IN7 _Ch1	IN6 _Ch2	IN6 _Ch1	IN5 _Ch2	IN5 _Ch1	IN4 _Ch2	IN4 _Ch1
	Input (two-channel)	0	IN3 _Ch 1&2	0	IN2 _Ch 1&2	0	IN1 _Ch 1&2	0	IN0 _Ch 1&2



The diagnostic data is transmitted to the standard control system via the configurable safety module.

### 2.8.2 PROFIsafe (PROFIBUS, PROFINET)

The module occupies four words in the Inline system and four words in the PROFIBUS system. The way in which these words are mapped in the higher-level control system is specific to the controller used and is described in the quick start guide for the controller.

## 2.9 Programming data/configuration data

### 2.9.1 Local bus (INTERBUS)

Table 2-3 Local bus (INTERBUS)

Protocol	SafetyBridge	PROFIsafe
Operating mode	Mode 2	Mode 1
ID code	A3 <sub>hex</sub> (163 <sub>dec</sub> )	CB <sub>hex</sub> (203 <sub>dec</sub> )
Length code	04 <sub>hex</sub> (04 <sub>dec</sub> )	04 <sub>hex</sub> (04 <sub>dec</sub> )
Input address area	Controller-specific	Controller-specific
Output address area	Controller-specific	Controller-specific
Parameter channel (PCP)	0 words	1 word
Register length	4 words	4 words



- The PCP channel is only used internally.
- The switch position of the protocol/address switch is specified by the configurable safety module (see documentation for the configurable safety module).

### 2.9.2 Other bus systems (PROFIBUS, PROFINET, etc.)



For the programming data/configuration data of other bus systems, please refer to the corresponding electronic device data sheet (GSD, EDS).

## 3 Inline potential and data routing, and Inline plugs

### 3.1 Inline potential and data routing

In order to operate the safety module it must be integrated in an Inline station within the SafetyBridge or PROFIsafe system.

The bus signals are transmitted via the Inline data jumpers. The required supply voltages are transmitted via the Inline potential jumpers.



For more detailed information on potential and data routing within an Inline station, please refer to the IL SYS INST UM E user manual.

The segment circuit is looped through the safety module and is available again after the module. The segment circuit cannot be accessed in the safety module.

### 3.2 Supply voltage $U_L$

Supply the 24 V supply voltage  $U_{BK}/U_{24V}$  at a bus coupler or a suitable power terminal (IB IL 24 PWR IN/R). The 7.5 V voltage  $U_L$  is generated from this 24 V supply voltage in the bus coupler or power terminal. It is supplied to the safety module via the Inline potential jumper  $U_L$ .



**WARNING: Loss of the safety function when using unsuitable power supplies**

Please note for the voltage supply at the bus coupler or power terminal that:  
 Only power supplies according to EN 50178/VDE 0160 (PELV) may be used.  
 Make sure that the output voltage of the power supply does not exceed 32 V even in the event of an error.  
 Please also observe the points in Section "Electrical safety" on page 1-3.

The supply voltage  $U_L$  is used to supply the communications power. For the technical data for the supply voltage  $U_L$ , please refer to "Supply voltage  $U_L$  (logic)" on page 1-3.

The maximum current carrying capacity for the supply voltage  $U_L$  is 2 A.

This current carrying capacity can be reduced if certain terminals are used. Please refer to the information in the terminal-specific data sheets.

### 3.3 Supply voltage $U_M$

Supply the supply voltage at a bus coupler or a power terminal. It is supplied to the safety module via the Inline potential jumper  $U_M$ .



**WARNING: Loss of the safety function when using unsuitable power supplies**

Please observe the points in Section "Electrical safety" on page 1-3.

The supply voltage  $U_M$  is used to supply the input circuits and the clock outputs. For the technical data for the supply voltage  $U_M$ , please refer to Section "Supply voltage  $U_M$  (sensors, clock outputs)" on page 1-4.

The maximum current carrying capacity for the main circuit  $U_M$  is 8 A (total current with the segment circuit that is not used in the safety terminal). This current carrying capacity can be reduced if certain terminals are used. Please refer to the information in the terminal-specific data sheets.

If the limit value of the potential jumpers  $U_M$  and  $U_S$  is reached (total current of  $U_S$  and  $U_M$ ), a new power terminal must be used.



**NOTE: Module damage due to polarity reversal**

Polarity reversal places a burden on the electronics and, despite protection against polarity reversal, can damage the module. Therefore, polarity reversal must be prevented.

For the behavior of the safety module in the event of an error at the supply voltage  $U_M$ , please refer to Section “Supply voltage errors” on page 9-5.

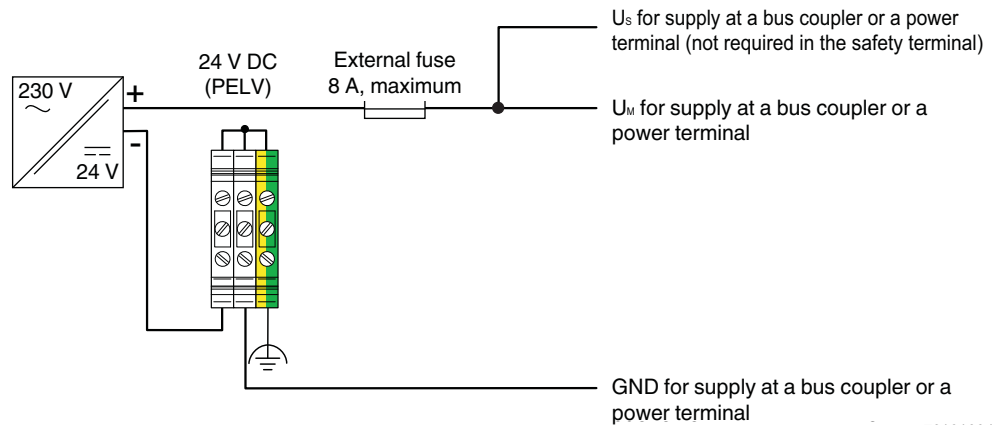

76191004

Figure 3-1 Supply  $U_M$  with connection to functional earth ground according to EN 60204-1



**NOTE: Damage to module electronics in the event of surge voltage**

Do not use a DC distribution network.

DC distribution network according to IEC 61326-3-1:

A DC distribution network is a DC power supply network, which supplies a complete industrial hall with DC voltage and to which any device can be connected. A typical system or machine distribution is not a DC distribution network. For devices that are provided for a typical system or machine distribution, the DC connections are viewed and tested as I/O signals according to IEC 61326-3-1.

### 3.4 Terminal point assignment

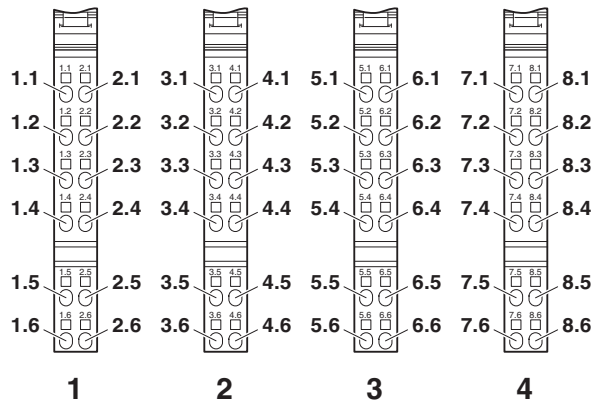

Figure 3-2 Terminal point assignment

The Inline plugs are supplied with the module. They are keyed and marked accordingly for connection to prevent polarity reversal.



Only use the plugs supplied with the module.

**The following applies for the tables below:**

- All inputs are safe digital inputs
- 0 V (GND): common ground of inputs and clock outputs
- FE: common functional earth ground

Table 3-1 Terminal point assignment for plug 1

Terminal point	Signal	Channel assignment	LED
1.1	IN0_Ch1	Input 0, channel 1	0.1
2.1	IN0_Ch2	Input 0, channel 2	0.2
1.2	UT1	Clock output 1	UT1
2.2	UT2	Clock output 2	UT2
1.3	0 V (GND)	Channel 1 and channel 2	
2.3	0 V (GND)	Channel 1 and channel 2	
1.4	IN1_Ch1	Input 1, channel 1	1.1
2.4	IN1_Ch2	Input 1, channel 2	1.2
1.5	UT1	Clock output 1	UT1
2.5	UT2	Clock output 2	UT2
1.6	0 V (GND)	Channel 1 and channel 2	
2.6	0 V (GND)	Channel 1 and channel 2	



Table 3-2 Terminal point assignment for plug 2

Terminal point	Signal	Channel assignment	LED
3.1	IN2_Ch1	Input 2, channel 1	2.1
4.1	IN2_Ch2	Input 2, channel 2	2.2
3.2	UT1	Clock output 1	UT1
4.2	UT2	Clock output 2	UT2
3.3	0 V (GND)	Channel 1 and channel 2	
4.3	0 V (GND)	Channel 1 and channel 2	
3.4	IN3_Ch1	Input 3, channel 1	3.1
4.4	IN3_Ch2	Input 3, channel 2	3.2
3.5	UT1	Clock output 1	UT1
4.5	UT2	Clock output 2	UT2
3.6	0 V (GND)	Channel 1 and channel 2	
4.6	0 V (GND)	Channel 1 and channel 2	

Table 3-3 Terminal point assignment for plug 3

Terminal point	Signal	Channel assignment	LED
5.1	IN4_Ch1	Input 4, channel 1	4.1
6.1	IN4_Ch2	Input 4, channel 2	4.2
5.2	UT1	Clock output 1	UT1
6.2	UT2	Clock output 2	UT2
5.3	0 V (GND)	Channel 1 and channel 2	
6.3	0 V (GND)	Channel 1 and channel 2	
5.4	IN5_Ch1	Input 5, channel 1	5.1
6.4	IN5_Ch2	Input 5, channel 2	5.2
5.5	UT1	Clock output 1	UT1
6.5	UT2	Clock output 2	UT2
5.6	0 V (GND)	Channel 1 and channel 2	
6.6	0 V (GND)	Channel 1 and channel 2	

Table 3-4 Terminal point assignment for plug 4

Terminal point	Signal	Channel assignment	LED
7.1	IN6_Ch1	Input 6, channel 1	6.1
8.1	IN6_Ch2	Input 6, channel 2	6.2
7.2	UT1	Clock output 1	UT1
8.2	UT2	Clock output 2	UT2
7.3	0 V (GND)	Channel 1 and channel 2	

Table 3-4 Terminal point assignment for plug 4

Terminal point	Signal	Channel assignment	LED
8.3	0 V (GND)	Channel 1 and channel 2	
7.4	IN7_Ch1	Input 7, channel 1	7.1
8.4	IN7_Ch2	Input 7, channel 2	7.2
7.5	UT1	Clock output 1	UT1
8.5	UT2	Clock output 2	UT2
7.6	0 V (GND)	Channel 1 and channel 2	
8.6	0 V (GND)	Channel 1 and channel 2	



**WARNING: Loss of functional safety due to parasitic voltages**

For sensors that require a GND, this must be wired to 0 V (GND) on the plug for the input.

## 4 Assembly, removal, and electrical installation

### 4.1 Assembly and removal

#### 4.1.1 Unpacking the module

The module is supplied in an ESD box together with a package slip with installation instructions. Please read the complete package slip carefully.

The module may only be installed and removed by qualified personnel.

**NOTE: Electrostatic discharge**

The safety module contains components that can be damaged or destroyed by electrostatic discharge. When handling the safety module, observe the necessary safety precautions against electrostatic discharge (ESD) according to EN 61340-5-1 and EN 61340-5-2.

#### 4.1.2 General

**WARNING: Unintentional machine startup**

Do not assemble or remove the module while the power is connected.

Before assembling or removing the module, disconnect the power to the module and the entire Inline station and ensure that it cannot be switched on again.

Make sure the entire system is reassembled before switching the power back on.

Observe the diagnostic indicators and any diagnostic messages.

The system may only be started provided neither the station nor the system poses a hazard.

The IB IL 24 PSDI 16-PAC safety terminal is designed for use within an Inline station. Only use the safety terminal in the 24 V DC area of an Inline station.

To ensure reliable operation, install the safety terminal in housing protected from dust and humidity (IP54 or higher). In order to prevent manipulation, secure the housing (control cabinet/control box) against being opened by unauthorized persons.

Mount all Inline terminals on 35 mm DIN rails.

Only connect the cables using the supplied Inline plugs or Inline plugs listed in the ordering data.

### 4.1.3 Setting the DIP switches

The module has a 2-pos. and a 10-pos. DIP switch.

The DIP switches are located on the left-hand side of the safety module.

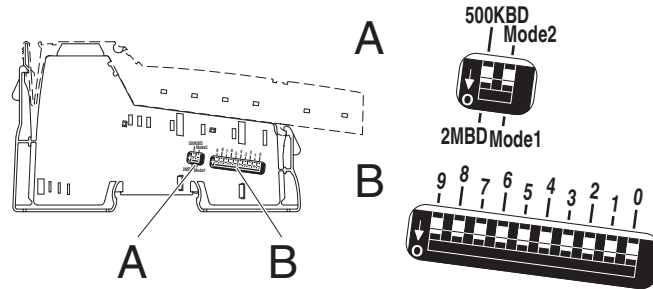

Figure 4-1 DIP switch

- A Switch for setting the transmission speed and the operating mode
- B Switch for setting the address

**2-pos. DIP switch:**

The transmission speed and the operating mode (Mode) are set via the 2-pos. DIP switch.

**Left switch:  
Transmission speed**

The transmission speed can be set to 500 kbaud or 2 Mbaud.  
The transmission speed is set to 2 Mbaud by default.



Only use devices with a uniform transmission speed within an Inline station (a local bus). It is not possible to operate a mixture of devices with different transmission speeds.

**Right switch:  
Mode**

For PROFIsafe, set Mode 1.  
For SafetyBridge, set Mode 2.

**10-pos. DIP switch: proto-  
col/address**

The SafetyBridge address or the PROFIsafe address (F-Address) is set via the 10-pos. DIP switch.



For more detailed information on the SafetyBridge address, please refer to the documentation for the configurable safety module used.

**PROFIsafe:** set the PROFIsafe address for the PROFIsafe device. PROFIsafe addresses 1 to 1023 (1<sub>hex</sub> to 3FF<sub>hex</sub>) are permitted.

**Overview of the switch positions**

Table 4-1 Switch position for SafetyBridge V3

SafetyBridge										
Mode switch	Address switch									
	Island number					Satellite number				
	9	8	7	6	5	4	3	2	1	0
Mode 2										
	1 <sub>dec</sub> to 31 <sub>dec</sub>					1 <sub>dec</sub> to 16 <sub>dec</sub>				

Table 4-2 Switch position for PROFIsafe

PROFIsafe										
Mode switch	Address switch									
	9	8	7	6	5	4	3	2	1	0
Mode 1										
1 <sub>hex</sub> to 3FF <sub>hex</sub>										

**Procedure**

If the DIP switch settings have to be modified, proceed as follows:

- Use the switch to set the transmission speed to 500 kbaud or 2 Mbaud.
- Set the protocol/address.



Set the DIP switches **before** assembling the module in the Inline station. The switches cannot be accessed when the safety terminal is installed in the Inline station.

**4.1.4 Assembly and removal of the safety module**



For general information on assembling and removing Inline terminals, please refer to the IL SYS INST UM E user manual.

**Assembly**



- Set the DIP switches prior to assembly (see Section “Setting the DIP switches” on page 4-2). The DIP switches cannot be accessed when the safety module is installed in the Inline station.
- Observe a mounting distance of 30 mm above and 40 mm below the safety module. Shorter distances may inhibit proper handling during installation.

**– Snap on base**

- Disconnect the power to the station.
- Before snapping on the safety module, remove the inserted plugs from the safety terminal and the adjacent plugs from the neighboring Inline terminal on the left. This prevents the potential routing knife contacts and the keyway/featherkey connections from being damaged.
- Hold the safety module perpendicular and snap it onto the DIN rail (7.5 mm in height).



Ensure that **all** featherkeys and keyways on adjacent terminals are **securely** interlocked.

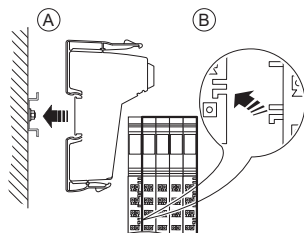

Figure 4-2 Snapping on the safety module base

**– Insert plugs**

- Check that all the snap-on mechanisms are securely snapped into place.
- Insert the plugs in the specified order (A, B).



Only use the plugs supplied with the module.

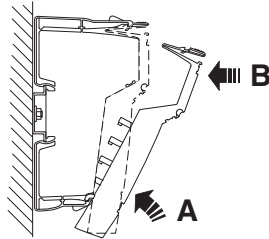

Figure 4-3 Inserting the plug

**Removal**

- Disconnect the power to the station.
- Before snapping on the safety module, remove the plugs from the safety module and the adjacent plug from the neighboring Inline terminal on the left.

**– Remove plugs**

- Remove the plug by pressing the back shaft latching (A) and levering off the plug (B).

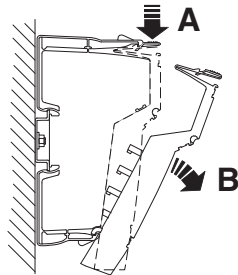

Figure 4-4 Removing the plug

**– Remove base**

- Release the base by pressing on the front and back snap-on mechanisms (A) and pull it out perpendicular to the DIN rail (B).

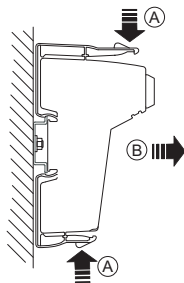

Figure 4-5 Removing the safety module base

## 4.2 Electrical installation



### **WARNING: Electric shock/unintentional machine startup**

Prior to electrical installation, disconnect the power to the system and make sure that it cannot be switched on again unintentionally.

Make sure installation has been completed before switching the power back on.

The system may only be started provided the system does not pose a hazard.

### 4.2.1 Electrical installation of the Inline station

Electrical installation of the Inline station includes the following:

- Connecting the bus system to the Inline station
- Connecting the supply voltages for the Inline station

Carry out electrical installation for the Inline station according to the IL SYS INST UM E user manual. Please also observe the specifications in the documentation for the bus coupler used.

### 4.2.2 Electrical installation of the safety module



During installation, always observe the instructions in “Electrical safety” on page 1-3.

Take measures to prevent the incorrect connection, polarity reversal, and manipulation of connections.

The supply voltages are supplied at a bus coupler and/or a power terminal and are supplied to the safety module via the potential jumpers. Therefore the electrical installation of the safety module only involves connecting the sensors.

The sensors are connected via Inline plugs.

- Wire the plugs according to your application. For the terminal point assignment, please refer to Section “Terminal point assignment” on page 3-3.

For wiring, proceed as follows:

- Strip 8 mm off the cable.



Inline wiring is normally done without ferrules. However, it is possible to use ferrules. If using ferrules, make sure they are properly crimped.

- Push a screwdriver into the slot of the appropriate terminal point (Figure 4-6, detail 1), so that you can insert the wire into the spring opening. Phoenix Contact recommends using a SZF 1 - 0,6X3,5 screwdriver (Order No. 1204517; see Phoenix Contact “CLIPLINE” catalog).
- Insert the wire (Figure 4-6, detail 2). Remove the screwdriver from the opening. This clamps the wire.

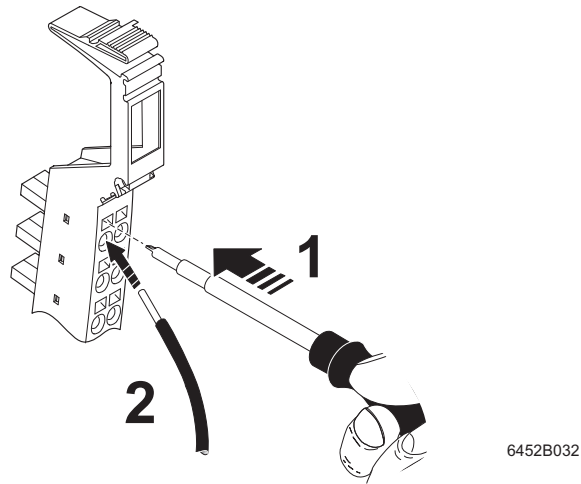

Figure 4-6 Connecting unshielded cables

- Insert the assembled plugs in the corresponding module slot (see Section “Terminal point assignment” on page 3-3).
- Mark all connections to prevent connections to the Inline plugs being mixed up (see IL SYS INST UM E user manual).



## 5 Parameterization of the safety module

### 5.1 Parameterization in a SafetyBridge system

Parameterization includes the following:

- Assigning the SafetyBridge address for the corresponding configurable safety module
- Parameterizing the inputs

#### SafetyBridge address

The SafetyBridge address is a unique ID for the safety module in the SafetyBridge structure. It is assigned in the configuration software for the assigned configurable safety module.

The address of the connected satellites (here: IB IL 24 PSDI 16-PAC) is based on the island number of the configurable safety module and the position in the bus navigator of the software tool.

Set this address via the DIP switches prior to assembling the safety module (see “Setting the DIP switches” on page 4-2).



For more detailed information on the SafetyBridge address, please refer to the documentation for the configurable safety module used.

#### Parameterization of inputs

The parameterization of the safe inputs determines the behavior of the module and therefore has a considerable effect on the safety integrity level that can be achieved.

To parameterize the module, the parameterization of the configurable safety module created in the parameterization tool is automatically written to the module on every power up or reset. The supply voltage must be present and the local bus must be in the RUN state.

The module cannot be operated if it is not parameterized. In this case, the FS LED flashes.

The module is ready to operate if the parameters for all inputs are valid and transmitted without errors. Valid input data is only read in this state. In every other state, the safe state is transmitted for each input (“0” in the process image of the inputs).

If errors are detected during parameterization, the parameterization data is not transmitted. The FS LED on the module flashes to indicate that the parameterization is invalid. In addition, errors are indicated at the configurable safety module. In this case, check and correct the settings.

## 5.2 Parameterization in a PROFIsafe system

Parameterization includes the following:

- Assigning the PROFIsafe address via the configuration software of the control system manufacturer
- Parameterizing the inputs
- Assigning the parameterizable F-Parameters and iParameters

### **PROFIsafe address**

The PROFIsafe address is a unique ID for the safety module in the PROFIsafe structure. It is assigned in the configuration software. Set this address via the DIP switches prior to assembling the safety module (see “Setting the DIP switches” on page 4-2).

### **Parameterization of inputs**

The parameterization of the safe inputs determines the behavior of the module and therefore has a considerable effect on the safety integrity level that can be achieved.

To parameterize the module, the parameterization of the safe controller created in the parameterization tool is automatically written to the module on every power up or reset.

The following conditions must be met:

- The supply voltage is present.
- The local bus is in the RUN state.
- The communication connection has been established between the controller and safety module.

The module cannot be operated if it is not parameterized.

In this case, the FS LED flashes.

The module is ready to operate if the parameters for all inputs are valid and transmitted without errors. Valid input data is only read in this state. In every other state, the safe state is transmitted for each input (“0” in the process image of the inputs).

If errors are detected during parameterization, the parameterization data is not transmitted. The FS LED on the module flashes to indicate that the parameterization is invalid.

In addition, errors are indicated at the safe controller. In this case, check and correct the settings. For information on error messages and instructions for their removal, please refer to Section “Errors: messages and removal” on page 9-1.

### **F-Parameters and iParameters**

Assign the parameterizable F-Parameters and iParameters. For an overview of the module parameters and possible settings, please refer to “Appendix: F-Parameters and iParameters” on page B-1.

### 5.3 Parameterization of the safe inputs

Each input pair of a safety module can be parameterized differently and can therefore achieve different safety integrity levels (SIL, SIL CL, Cat., PL).

#### Two-channel

If the inputs are operated via two channels, the following fixed assignment applies:

- IN0\_Ch1 to IN0\_Ch2
- IN1\_Ch1 to IN1\_Ch2
- IN2\_Ch1 to IN2\_Ch2
- IN3\_Ch1 to IN3\_Ch2
- IN4\_Ch1 to IN4\_Ch2
- IN5\_Ch1 to IN5\_Ch2
- IN6\_Ch1 to IN6\_Ch2
- IN7\_Ch1 to IN7\_Ch2

For two-channel assignment, the inputs have a fixed assignment to one another. The input information of both inputs is mapped to one bit. The unused bits are always set to "0".

#### Single-channel

If two-channel operation in the external wiring of the inputs is not required, the inputs can be parameterized in such a way that they operate independently of one another (single-channel).

#### Parameterization

Parameterize all safe input pairs in pairs. The parameterization options are described in Table 5-1.

Table 5-1 Parameterization of inputs

Parameterization	Value range	Remark
Assignment	<b>Not used</b> Used, both single-channel Two-channel equivalent Two-channel non-equivalent	Parameterization is always for one input pair. For unused inputs, the data is filled with 0. For "two-channel", the assignment of the inputs to one another is specified and cannot be modified.

Table 5-1 Parameterization of inputs [...]

Parameterization	Value range	Remark
Filter time ( $t_{Filter}$ )	<b>3 ms</b> 5 ms 15 ms	The filter time is used to suppress interference for the input signals. Select the filter time so that the duration of the input signal is greater than the filter time. For inputs that are parameterized for two-channel operation, select the same filter time for both channels.
	 The filter time directly affects the response time of the safety function.	
Symmetry	<b>Disabled</b> 100 ms 1 s 5 s	Parameterization is only active if the input is parameterized for two-channel operation. Select the same value for both channels.  See also "Symmetry/ start inhibit" on page 5-4.
Start inhibit due to symmetry violation	<b>Disabled</b> Enabled	Disabled (default setting): a diagnostic message is generated in the event of symmetry violation.  Enabled: a diagnostic message is generated in the event of symmetry violation. In addition, the affected input is set to the safe state.
Cross-circuit detection	No cross-circuit monitoring <b>Cross-circuit monitoring</b> INx_CH1 -> UT1 INx_CH2 -> UT2	As soon as cross-circuit monitoring is enabled for an assigned input pair, clock outputs UT1 and UT2 are clocked. Otherwise they are enabled without clocking.



The default values are shown in bold.

**Symmetry/  
start inhibit**

Symmetry monitoring can be used to monitor the contact wear of the switch. Symmetry monitoring checks the extent to which the related (filtered) inputs enter another state simultaneously. Symmetry is violated if the inputs indicate different states for a time greater than the value parameterized for "symmetry". This applies for positive and negative edges.

The safe controller (PROFIsafe) or the configurable safety module (SafetyBridge) is informed of a symmetry violation by a diagnostic message. If "start inhibit due to symmetry violation" is enabled, symmetry violation locks the affected input.

Key for the following diagrams:

S Symmetry monitoring

Diag Diagnostics

Q Acknowledgment of the diagnostic message; after acknowledging the diagnostic message, the current state is read.



For non-equivalent parameterization, a negated signal is present at input IN0\_Ch2 shown in the diagrams.

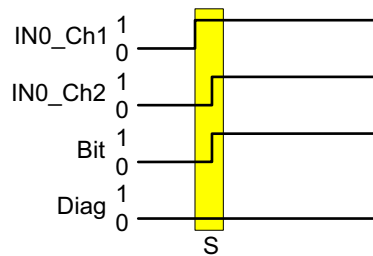

Figure 5-1 Example for a signal change within the parameterized time for symmetry monitoring 76020007

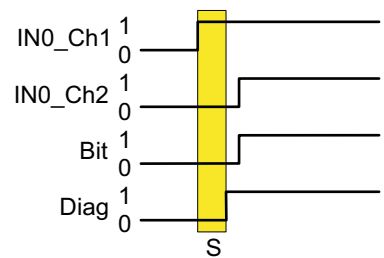
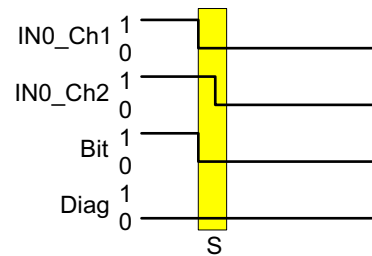

Figure 5-2 Example for a signal change outside the parameterized time for symmetry monitoring; start inhibit due to symmetry violation is disabled 76020008

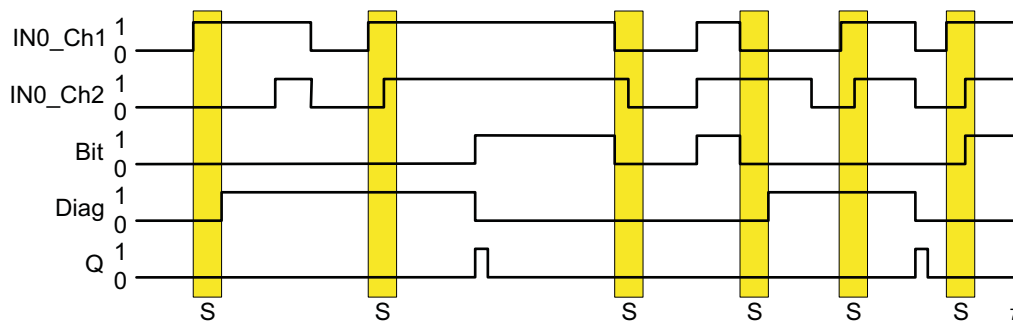

Figure 5-3 Example for a signal change outside the parameterized time for symmetry monitoring; start inhibit due to symmetry violation is enabled 76020009



After acknowledging the diagnostic message (see Section “Acknowledging an error” on page 9-8), the current state at the input is immediately transmitted to the safe controller (PROFIsafe) or the configurable safety module (SafetyBridge). If a startup inhibit is required following error acknowledgment, this must be implemented by the user in the application program.



A symmetry violation can also be triggered by a cross circuit (see Section “Connection examples for safe inputs” on page 7-1).

**Processing time of the input  $t_{IN}$  in the event of a safety demand**

The processing time of the input  $t_{IN}$  in the event of a safety demand comprises the parameterized filter time  $t_{Filter}$  and the firmware runtime  $t_{FW}$ . It is calculated for the IB IL 24 PSDI 16-PAC module according to the following formula:

$$t_{IN} = t_{Filter} + t_{FW}$$

Where:

- $t_{IN}$             Processing time of the input
- $t_{Filter}$         Parameterized filter time
- $t_{FW}$             Firmware runtime: 250  $\mu$ s

**5.4    Parameterization of clock outputs UT1 and UT2**

As long as the module is not parameterized:

- The clock outputs are enabled if no errors are present.
- Short-circuit detection is activated.

The clock output settings are specified by the parameterization of the safe inputs. If all safe inputs are parameterized without cross-circuit monitoring, an unlocked DC voltage can be tapped at both clock outputs.

If cross-circuit detection is activated for at least one safe input, Low pulses with a maximum pulse width of 1 ms and a maximum period length of 40 ms are output at the clock outputs. The time offset between the clocks of the clock outputs is approximately 50% of the period length.



If clock outputs are parameterized without clock pulses, no cross circuits or short circuits can be detected between the channels.

If clocking is enabled, the clock output is operated with a maximum pulse width of 1 ms and a maximum period length of 40 ms.

The time offset between the clocks of the clock outputs is approximately 50% of the period length.

**Typical pulse pattern**

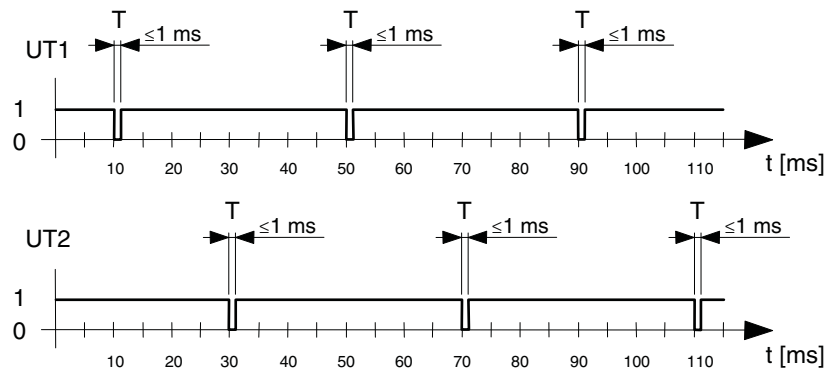

73410011

Figure 5-4    Typical pulse pattern

Key:

T     Test pulse  
      Pulse width  $\leq 1$  ms  
      Period length  $\leq 40$  ms

## 6 Duration of a safety demand

The duration of a safety demand must be greater than the processing time of the corresponding input ( $t_{IN}$ , see also "Processing time of the input  $t_{IN}$  in the event of a safety demand" on page 5-6).

### 6.1 SafetyBridge

If the safety module detects a safety demand after the processing time of the input  $t_{IN}$  has elapsed, when using SafetyBridge this time is extended by the module until the configurable safety module has received the safety demand.

### 6.2 PROFIsafe

If the safety module detects a safety demand (safe "0") after the processing time of the input  $t_{IN}$  has elapsed, when using PROFIsafe this time is extended by the module until the consecutive number has changed twice.

**WARNING: Loss of functional safety**

Observe the behavior of the controller when processing the safe inputs.

In addition to the processing time of the input  $t_{IN}$ , please observe the system-specific PROFIsafe behavior (e.g., watchdog time, duration of demand, processing time of the safe controller).



## 7 Connection examples for safe inputs

### 7.1 Explanation of the examples

Depending on the type of wiring, the inputs of a module can achieve different safety integrity levels (SIL, SIL CL, Cat., PL) simultaneously (as long as the settings do not contradict one another).

The following examples only describe the options for the electrical connection of sensors to the safe inputs.

Should you have any questions regarding applications to be implemented, please contact the Phoenix Contact safety hotline (see “Safety hotline” on page 1-8).

The following are specified for each example:

- **Basic specifications**  
The main data for the example is specified in the table.
- **Device diagnostics and behavior of the module in the event of an error**  
Diagnostic capability depends on the parameterization.  
If a message is transmitted to the safe controller (PROFIsafe) or the configurable safety module (SafetyBridge) in the event of an error, the message is specified in the tables. For information on the relevant error code, possible solutions, and information as to whether acknowledgment is required, please refer to Section “Errors: messages and removal” on page 9-1.  
The symmetry violation diagnostic message is only displayed if it was not disabled during parameterization of the affected input.
- **Typical parameterization**  
The table illustrates an example of all the parameters for the specified assignment.

Key for all figures and tables in this section:

Table 7-1 Figures

Representation	Meaning
	Floating switch (mechanical or electrical)

Table 7-2 “Device diagnostics and behavior of the module in the event of an error” tables

Representation	Meaning
SF	Safety function
UTx	UT1 or UT2 LED; diagnostic message for each clock output
Clocked	Clocking enabled

Table 7-3 Parameterization tables

Representation	Meaning
<b>Bold</b>	Mandatory setting
Normal	Typical setting, another setting is possible depending on the application
–	Not evaluated

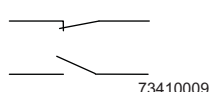
Errors (cross circuits, short circuits), which can be prevented by correct installation (e.g., protected cable installation, isolated cable installation, double insulation, use of ferrules) are not described in the following tables.

Therefore, for example, only errors between inputs, which are on the same plug, are described. For example, in the event of correct installation, cross circuits with inputs/outputs of other plugs cannot occur.



For all examples, please also observe the measures specified in the individual tables, which must be taken to achieve the specified SIL/SIL CL/Cat./PL and all measures according to standards EN 61508, EN 62061, and EN ISO 13849-1 to achieve the specified SIL/SIL CL/Cat./PL.

The assignment of the input signals to the clock outputs is parameterized as required.

## 7.2 Measures required to achieve a specific safety integrity level

The safety integrity level (SIL, SIL CL, performance level, and category) that can be achieved is specified for each connection example.

### SIL/SIL CL



In order to determine the probability of failure according to EN 61508 (SIL), use this standard.  
 In order to determine the probability of failure according to EN 62061 (SIL CL), use this standard.

When the SIL/SIL CL is specified, the module takes up 1% of the specified SIL/SIL CL.

Table 7-4 PFD and PFH depending on the SIL/SIL CL

	PFD	PFH
SIL 2/SIL CL 2	1% of $10^{-2}$	1% of $10^{-6}$
SIL 3/SIL CL 3	1% of $10^{-3}$	1% of $10^{-7}$

### Performance level



Use standard EN ISO 13849-1 to determine the performance level.

### Category

In order to actually achieve the specified category, the required measures listed below must be implemented.

#### Cat. 2

- Use proven and basic safety principles according to EN ISO 13849-2.
- Use appropriately qualified sensors (see Section "Requirements for controlling devices/sensors" on page 2-5).
- Please note that mechanical failure of the switching device can result in the loss of the safety function.
- Take appropriate measures (e.g., fuse protection, redundancy, positive opening, etc.) to ensure that the contacts can be opened (e.g., following welding or mechanical failure) when a switch is actuated.
- Please note that **a single** error can result in the loss of the safety function between tests.
- Ensure that the external wiring is tested by the machine control system on machine startup and at suitable intervals. This test must detect the loss of the safety function.

**Cat. 3**

- Use proven and basic safety principles according to EN ISO 13849-2.
- Use appropriately qualified sensors (see Section “Requirements for controlling devices/sensors” on page 2-5).
- Please note that mechanical failure of the switching device can result in the loss of the safety function.
- Take appropriate measures (e.g., fuse protection, redundancy, positive opening, etc.) to ensure that the contacts can be opened (e.g., following welding or mechanical failure) when a switch is actuated.
- Please take into consideration errors with a common cause.
- All errors that cannot be detected can result in the loss of the safety function. Take appropriate measures to prevent such errors. Suitable measures include, for example, protected cable installation or double insulation. Please note the information in the following tables.
- Ensure that a **single** error does not result in the loss of the safety function.
- If single-channel sensors are not available for this category, use two-channel sensors.

**Cat. 4**

- Use proven and basic safety principles according to EN ISO 13849-2.
- Use appropriately qualified sensors (see Section “Requirements for controlling devices/sensors” on page 2-5).
- Please note that mechanical failure of the switching device can result in the loss of the safety function.
- All errors that cannot be detected can result in the loss of the safety function. Take appropriate measures to prevent such errors. Suitable measures include, for example, protected cable installation or double insulation. Please note the information in the following tables.
- An accumulation of errors must not result in the loss of the safety function. Following the third error, evaluation can be aborted if the probability of further errors occurring is low.
- Please take into consideration errors with a common cause.

### 7.3 Single-channel assignment of safe inputs

For the single-channel assignment of safe inputs, the inputs operate independently of one another. The assignment of each input signal to the clock output cannot be freely selected.

For the following examples, please note the resulting behavior in the event of an error:



#### Note about cross circuits

- Please note that cross circuits with other inputs can only be detected if cross-circuit monitoring is enabled.
- The **cross circuit** error results in the transmission of the safe state in the process data image of the affected inputs.  
Remove the error and then acknowledge the message.
- Please observe the maximum failure detection time of 64 ms.  
If a “1” signal is present at the input and an error occurs, a maximum of 64 ms elapses until the error is detected. Within this time, another “1” can also be transmitted, even in the event of an error.  
Within the failure detection time (64 ms, maximum), the error can cause the state to change unexpectedly from “0” to “1”.

**Ensure that such a change in state cannot restart the system unintentionally.**

**Please note that the processing time for the input  $t_{IN}$  increases by up to 64 ms in the event of an error.**

For supply for single-channel assignment, use the relevant clock output or an external supply (external +24 V or OSSD).

#### State evaluation

The module evaluates the states of the inputs and transmits the result to the safe controller (PROFIsafe) or the configurable safety module (SafetyBridge).

In the process data image of a safe input:

- A “0” is transmitted if a “0” signal is present at the input **or** an error has been detected.
- A “1” is transmitted if a “1” signal is present at the input **and** no error has been detected.

### 7.3.1 Single-channel with cross-circuit monitoring

If an input pair is parameterized as single-channel with cross-circuit monitoring, the following fixed assignment applies:

- INx\_Ch1 is permanently assigned to clock output UT1
- INx\_Ch2 is permanently assigned to clock output UT2

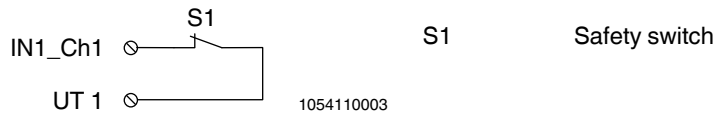

Figure 7-1 Single-channel assignment of inputs

#### Basic specifications

<b>Sensor</b>	Single-channel
<b>Sensor supply</b>	Internally through clock output UT1 (clocked) or UT2 (clocked)
<b>Achievable SIL/SIL CL/Cat./PL</b>	SIL 2/SIL CL 2/Cat. 3/PL d



**WARNING: Loss of electrical and functional safety**

- To achieve the specified category, please refer to Section “Measures required to achieve a specific safety integrity level” on page 7-3.
- Please note that in order to achieve the specified PL, the sensor must have a medium level of diagnostic coverage (90% to 99%) and medium MTTFd. A high level of diagnostic coverage (> 99%) is recommended for the application according to PL d.
- Use sensors that can achieve the required safety integrity level.

#### Device diagnostics and behavior of the module in the event of an error

Table 7-5 Single-channel: supply through UT1 (clocked) or UT2 (clocked)

Error type	Detection	Diagnostics	Loss of SF	Remark
<b>Error in the sensor</b>				
A contact will not open	No	None	Yes	The error cannot be detected and results in the loss of the safety function.
A contact will not close	No	None	No	The error cannot be detected.
Other errors (depending on the sensor)				<b>Please take into consideration possible errors that can occur in the sensor.</b>
<b>Error in the wiring</b>				
<b>Interrupt</b>				
Input (Cable interrupt between clock output and sensor or between sensor and input)	Yes	None	No	<p>– <b>Behavior when the input is in state “1”:</b> The error is detected as a change in state from “1” to “0”. An unexpected change from “0” to “1” is possible (e.g., due to a loose contact). <b>Ensure that such a change in state cannot restart the system unintentionally.</b></p> <p>– <b>Behavior when the input is in state “0”:</b> <b>Please note that if this error causes the safety switch to be switched on again, this can result in delayed transmission of state “1” in the process data image of the inputs (e.g., due to a loose contact).</b></p>

Table 7-5 Single-channel: supply through UT1 (clocked) or UT2 (clocked) [...]

Error type	Detection	Diagnostics	Loss of SF	Remark
<b>Cross circuit</b>				
Input to input	No	None	Yes	The error cannot be detected and results in the loss of the safety function, as the safety switch is bypassed. If the inputs are assigned different clock outputs, this error is detected as a cross circuit after 64 ms.
Input to assigned clock output	No	None	Yes	The error cannot be detected and results in the loss of the safety function, as the safety switch is bypassed.
Input to non-assigned clock output	Yes	Cross circuit	No	See "Note about cross circuits" on page 7-5.
Clock output to clock output	Yes	Cross circuit	No	The error is only detected in state "1" of the input.
<b>Short circuit</b>				
Input to ground	Yes	None	No	The error is only detected as a change in state from "1" to "0" in state "1" of the input. An unexpected change from "0" to "1" is possible (e.g., due to a loose contact). <b>Ensure that such a change in state cannot restart the system unintentionally.</b>
Clock output to ground	Yes	Short circuit UTx ON	No	The affected clock output is disabled.

**Typical parameterization**

Parameterization	Parameterized as/value range	Remark
<b>Input xx channel 1/channel 2</b>		
Assignment	<b>Both single-channel</b>	
Filter time ( $t_{Filter}$ )	3 ms	Application-specific
Symmetry	Disabled	
Start inhibit due to symmetry violation	Disabled	
Cross-circuit monitoring	Cross-circuit monitoring	

### 7.3.2 Single-channel: supply through UT1 without cross-circuit monitoring

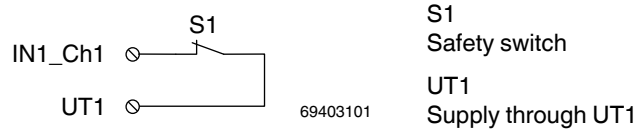

Figure 7-2 Single-channel assignment of inputs: supply through UT1

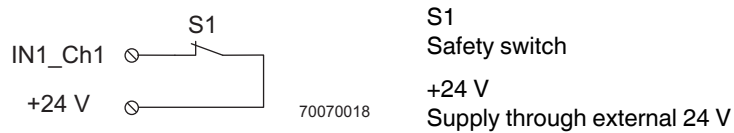

Figure 7-3 Single-channel assignment of inputs: external supply

#### Basic specifications

<b>Sensor</b>	Single-channel switch
<b>Sensor supply</b>	<ul style="list-style-type: none"> <li>- Internally through clock output UT1 or UT2; cross-circuit monitoring disabled</li> <li>- External (24 V)</li> </ul>
<b>Achievable SIL/SIL CL/Cat./PL</b>	SIL 2/SIL CL 2/Cat. 2/PL d



**WARNING: Loss of electrical and functional safety**

- To achieve the specified category, please refer to Section “Measures required to achieve a specific safety integrity level” on page 7-3.
- Please note that in order to achieve the specified PL, cross circuits must be avoided.
- Please note that in order to achieve the specified PL, the sensor must have a medium level of diagnostic coverage (90% to 99%) and high MTTFd. A high level of diagnostic coverage (> 99%) is recommended for the application according to PL d.
- Use sensors that can achieve the required safety integrity level.



Device diagnostics and behavior of the module in the event of an error

Table 7-6 Single-channel without cross-circuit monitoring: supply through UT1/UT2, external supply or OSSD

Error type	Detection	Diagnostics	Loss of SF	Remark
<b>Error in the sensor</b>				
A contact will not open	No	None	Yes	The error cannot be detected and results in the loss of the safety function.
A contact will not close	No	None	No	The error cannot be detected.
Other errors (depending on the sensor)				<b>Please take into consideration possible errors that can occur in the sensor.</b>
<b>Error in the wiring</b>				
<b>Interrupt</b>				
Input (Cable interrupt between clock output and sensor or between sensor and input)	Yes	None	No	<p>– <b>Behavior when the input is in state “1”:</b> The error is detected as a change in state from “1” to “0”. An unexpected change from “0” to “1” is possible (e.g., due to a loose contact). <b>Ensure that such a change in state cannot restart the system unintentionally.</b></p> <p>– <b>Behavior when the input is in state “0”:</b> <b>Please note that if this error causes the safety switch to be switched on again, this can result in delayed transmission of state “1” in the process data image of the inputs (e.g., due to a loose contact).</b></p>
<b>Cross circuit</b>				
Input to input	No	None	Yes	The error cannot be detected and results in the loss of the safety function, as the safety switch is bypassed.
Input to clock output	No	None	Yes	The error cannot be detected and results in the loss of the safety function, as the safety switch is bypassed.
<b>Short circuit</b>				
Input to external 24 V	No	None	Yes	The error cannot be detected and results in the loss of the safety function, as the safety switch is bypassed.
Input to ground	Yes	None	No	The error is only detected as a change in state from “1” to “0” in state “1” of the input. An unexpected change from “0” to “1” is possible (e.g., due to a loose contact). <b>Ensure that such a change in state cannot restart the system unintentionally.</b>
Clock output to external 24 V	No	None	No	The error cannot be detected as clocking is disabled.
Clock output to ground	Yes	Short circuit UTx ON	No	The affected clock output is disabled.
External 24 V to ground	Yes	None	No	The error is only detected as a change in state from “1” to “0” in state “1” of the input. An unexpected change from “0” to “1” is possible (e.g., due to a loose contact). <b>Ensure that such a change in state cannot restart the system unintentionally.</b>

Typical parameterization

Parameterization	Parameterized as/value range	Remark
<b>Input xx channel 1/channel 2</b>		
Assignment	Both single-channel	
Filter time ( $t_{Filter}$ )	3 ms	Application-specific
Symmetry	Disabled	
Start inhibit due to symmetry violation	Disabled	
Cross-circuit monitoring	No cross-circuit monitoring	

7.3.3 Single-channel: supply through OSSD

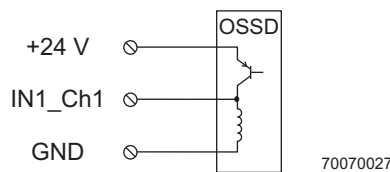

Figure 7-4 Single-channel assignment of inputs: external supply (OSSD)



**WARNING: Loss of functional safety due to parasitic voltages**

Connect the sensor ground directly to terminal point GND of the safety module. An external ground may not be used.

Basic specifications

<b>Sensor</b>	Single-channel OSSD output (with internal testing)
<b>Sensor supply</b>	External (OSSD sensor)
<b>Achievable SIL/SIL CL/Cat./PL</b>	SIL 2/SIL CL 2/Cat. 2/PL d



**WARNING: Loss of electrical and functional safety**

- To achieve the specified category, please refer to Section "Measures required to achieve a specific safety integrity level" on page 7-3.
- Please note that in order to achieve the specified PL, cross circuits must be avoided.
- Please note that in order to achieve the specified PL, the sensor must have a medium level of diagnostic coverage (90% to 99%) and high MTTFd. A high level of diagnostic coverage (> 99%) is recommended for the application according to PL d.
- Use sensors that can achieve the required safety integrity level.

Device diagnostics and behavior of the module in the event of an error

Table 7-7 Single-channel: supply through OSSD

Error type	Detection	Diagnostics	Loss of SF	Remark
<b>Error in the sensor</b>				

Table 7-7 Single-channel: supply through OSSD [...]

Error type	Detection	Diagnostics	Loss of SF	Remark
(Depends on the sensor)				<b>Please take into consideration possible errors that can occur in the sensor.</b>
<b>Error in the wiring</b>				
<b>Interrupt</b>				
Input (Cable interrupt between clock output and sensor or between sensor and input)	Yes	None	No	<p>– <b>Behavior when the input is in state “1”:</b> The error is detected as a change in state from “1” to “0”. An unexpected change from “0” to “1” is possible (e.g., due to a loose contact). <b>Ensure that such a change in state cannot restart the system unintentionally.</b></p> <p>– <b>Behavior when the input is in state “0”:</b> <b>Please note that if this error causes the safety switch to be switched on again, this can result in delayed transmission of state “1” in the process data image of the inputs (e.g., due to a loose contact).</b></p>
Input (Cable interrupt between sensor and GND)	No	None	No	The error must be detected by the sensor. <b>The sensor must ensure that the safe state is entered in the event of an error.</b>
<b>Cross circuit</b>				
Input to input	No	None	Yes	The error cannot be detected and results in the loss of the safety function, as the safety switch is bypassed.
Input to clock output	No	None	Yes	The error cannot be detected and results in the loss of the safety function, as the safety switch is bypassed.
<b>Short circuit</b>				
Input to external 24 V	No	None	Yes	The error cannot be detected and results in the loss of the safety function, as the safety switch is bypassed.
Input to ground	Yes	None	No	The error is only detected as a change in state from “1” to “0” in state “1” of the input. An unexpected change from “0” to “1” is possible (e.g., due to a loose contact). <b>Ensure that such a change in state cannot restart the system unintentionally.</b>
Clock output to external 24 V	No	None	No	The error cannot be detected as clocking is disabled.
Clock output to ground	Yes	Short circuit UTx ON	No	The affected clock output is disabled.
External 24 V to ground	Yes	None	No	The error is only detected as a change in state from “1” to “0” in state “1” of the input. An unexpected change from “0” to “1” is possible (e.g., due to a loose contact). Ensure that such a change in state cannot restart the system unintentionally.

**Typical parameterization**

Parameterization	Parameterized as/value range	Remark
<b>Input xx channel 1/channel 2</b>		
Assignment	<b>Both single-channel</b>	
Filter time ( $t_{Filter}$ )	3 ms	Application-specific
Symmetry	Disabled	
Start inhibit due to symmetry violation	Disabled	
Cross-circuit monitoring	No cross-circuit monitoring	



Set the filter time for the input to a value greater than the width of the test pulse for the OSSD sensor.

The input must be parameterized without cross-circuit monitoring.

## 7.4 Two-channel equivalent assignment of safe inputs

For two-channel assignment of the inputs, two adjacent inputs are always used. This assignment is fixed and cannot be parameterized (see Section “Two-channel” on page 5-3).

For two-channel equivalent assignment, the state changes from “0” to “1” only when both inputs change state from “0” to “1”. If symmetry monitoring is enabled and the state at both inputs does not change within the parameterized time, a diagnostic message is generated.

An input is active when the state of the signal is equal to “1”.



Cross circuits between different inputs can only be detected if the input signals are supplied by different clock outputs.



Please note that if a delayed change in state at one of the two inputs causes the safety switch to be switched on again, this can result in delayed transmission of state “1” in the process data image of the inputs (e.g., due to a loose contact).

### Example of correct and incorrect signal change

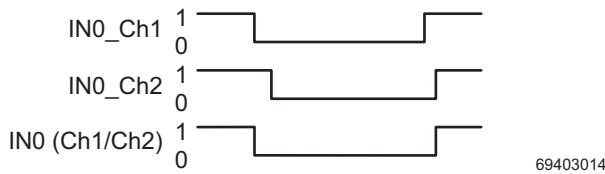

Figure 7-5 **Correct** signal change

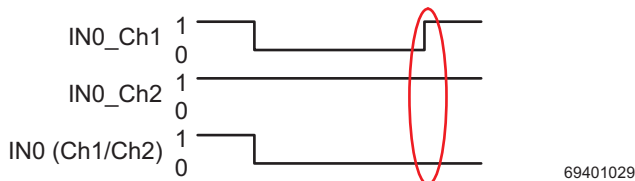

Figure 7-6 **Error** during signal change

In Figure 7-6, the condition that both signals must be in state “0” before the change in state from “0” to “1” is not met. In this case, diagnostic message 018x<sub>hex</sub> is generated.

Key for Figure 7-5 and Figure 7-6

IN0_Ch1	Signal sequence at input 0 channel 1
IN0_Ch2	Signal sequence at input 0 channel 2
IN0 (Ch1/Ch2)	Safety-related signal for two-channel input 0 channel 1 and channel 2 at the safe controller (PROFIsafe) or the configurable safety module (SafetyBridge)

### State evaluation

The module evaluates the states of the inputs and transmits the result to the safe controller (PROFIsafe) or the configurable safety module (SafetyBridge).

In the process data image of the safe inputs:

- A “0” is transmitted if a “0” signal is present at at least one of the two inputs **or** an error has been detected.
- A “1” is transmitted if a “1” signal is present at both inputs **and** no error has been detected and the conditions are met for a change in state according to Figure 7-6.

### 7.4.1 Notes about errors for two-channel equivalent assignment of safe inputs

For the following examples, please note the resulting behavior in the event of an error:



#### Note about cross circuits

- The **cross circuit** error results in the transmission of the safe state in the process data image of the affected inputs.  
Remove the error and then acknowledge the message.  
Acknowledging the diagnostic message deletes the message and activates the input. The states at the input are detected immediately. **In your safe application program, ensure that the system cannot be restarted unintentionally following acknowledgment of the diagnostic message.**
- Please observe the maximum failure detection time of 64 ms.  
Exceptions in the failure detection time are indicated in the tables.  
If a “1” signal is present at the input and an error occurs, a maximum of 64 ms elapses until the error is detected. Within this time, another “1” can also be transmitted, even in the event of an error.  
Within the failure detection time (64 ms, maximum), the error can cause the state to change unexpectedly from “0” to “1”.  
**Ensure that such a change in state cannot restart the system unintentionally.**



#### Note about symmetry violation

- The symmetry violation diagnostic message is only displayed if it was not disabled during parameterization of the affected input.
- **Start inhibit due to symmetry violation disabled:**  
The symmetry violation message does **not** result in the transmission of the safe state (see also “Symmetry/ start inhibit” on page 5-4).  
The message must be acknowledged. However, the current status of the inputs is displayed in the process data image of the inputs.
- **Start inhibit due to symmetry violation enabled:**  
The symmetry violation message results in the transmission of the safe state (see also “Symmetry/ start inhibit” on page 5-4).  
The message must be acknowledged. The current status of the inputs is displayed in the process data image of the inputs following acknowledgment.
- The message can be used to monitor the wear of the safety switch.

### 7.4.2 Two-channel equivalent cross-circuit monitoring enabled: supply through UT1 and UT2

Possible wiring versions:

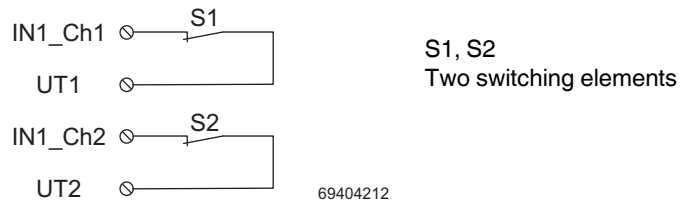

Figure 7-7 Two-channel equivalent assignment of inputs, supply through UT1 and UT2 (both clocked)

#### Basic specifications

<b>Sensor</b>	Two-channel equivalent with cross-circuit monitoring
<b>Sensor supply</b>	Internally through clock output UT1 <b>and</b> UT2 (both clocked)
<b>Achievable SIL/SIL CL/Cat./PL</b>	SIL 3/SIL CL 3/Cat. 4/PL e



**WARNING: Loss of electrical and functional safety**

- To achieve the specified category, please refer to Section "Measures required to achieve a specific safety integrity level" on page 7-3.
- Please note that in order to achieve the specified PL, the sensor must have a high level of diagnostic coverage (> 99%) and high MTTFd.
- Use sensors that can achieve the required safety integrity level.

Device diagnostics and behavior of the module in the event of an error



To understand the change in state, please refer to “Example of correct and incorrect signal change” on page 7-13.

Table 7-8 Two-channel equivalent with cross-circuit monitoring: supply through UT1 and UT2

Error type	Detection	Diagnostics	Loss of SF	Remark
<b>Error in the sensor</b>				
A contact will not open	Yes	Symmetry violation *)	No	The error is detected on a change in state, as the state only changes in one channel. – <b>Change in state from “1” to “0”:</b> The faulty input remains at “1”. A “0” is transmitted in the process data image of the affected inputs. – <b>Change in state from “0” to “1”:</b> A “0” is transmitted in the process data image of the affected inputs, as the faulty input was not previously set to state “0”.
A contact will not close	Yes	Symmetry violation	No	On a change in state from “0” to “1”, a “0” is transmitted in the process data image of the affected inputs, as only one channel reports this change in state.
Other errors (depending on the sensor)				<b>Please take into consideration all possible errors that can occur in the sensor.</b>
<b>Error in the wiring</b>				
<b>Interrupt</b>				
Input (Cable interrupt between clock output and sensor or between sensor and input)	Yes	Symmetry violation	No	The error is detected in state “1” or on a change in state from “0” to “1”, as the state only changes in one channel.
<b>Cross circuit</b>				
Input to input	Yes	Cross circuit	No	The error is detected in state “1”.
Input to assigned clock output	Yes	Symmetry violation	No	The error is detected on a change in state, as the state only changes in one channel. – <b>Change in state from “1” to “0”:</b> The faulty input remains at “1”. A “0” is transmitted in the process data image of the affected inputs. – <b>Change in state from “0” to “1”:</b> A “0” is transmitted in the process data image of the inputs, if the faulty input was not previously set to state “0”.
Input to non-assigned clock output	Yes	Cross circuit	No	See “Note about cross circuits” on page 7-14.
Clock output to clock output	Yes	Cross circuit	No	The error is detected for inputs, which are assigned to different clock outputs.
<b>Short circuit</b>				
Input to ground	Yes	Symmetry violation	No	The error is detected in state “1” or on a change in state from “0” to “1”, as the state only changes in one channel.
Clock output to ground	Yes	Short circuit UTx ON	No	The error is detected in state “1” or on a change in state from “0” to “1”, as the state only changes in one channel. The error is also detected as a short circuit of the clock output. The affected clock output is disabled.

\*) Only applies when symmetry monitoring is active



Typical parameterization

Parameterization	Parameterized as/value range	Remark
<b>Input xx channel 1/channel 2</b>		
Assignment	<b>Two-channel equivalent</b>	
Filter time ( $t_{\text{Filter}}$ )	3 ms	Application-specific
Symmetry	100 ms	Application-specific
Start inhibit due to symmetry violation	Enabled	Application-specific
Cross-circuit monitoring	Cross-circuit monitoring	

### 7.4.3 Two-channel equivalent cross-circuit monitoring disabled: supply through a clock output or external supply

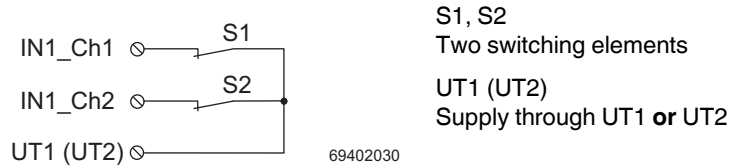

Figure 7-8 Two-channel equivalent assignment of inputs, supply through UT1 (or UT2) cross-circuit monitoring disabled

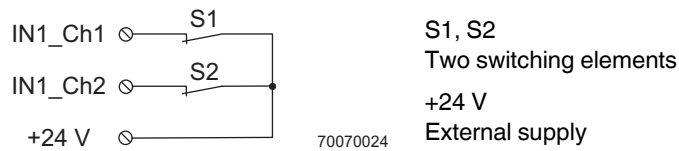

Figure 7-9 Two-channel equivalent assignment of inputs, external supply, cross-circuit monitoring disabled

#### Basic specifications

<b>Sensor</b>	Two-channel equivalent
<b>Sensor supply</b>	Internally through clock output UT1 (or UT2) <b>or</b> externally
<b>Achievable SIL/SIL CL/Cat./PL</b>	SIL 3/SIL CL 3/Cat. 3/PL d



**WARNING: Loss of electrical and functional safety**

- To achieve the specified category, please refer to Section “Measures required to achieve a specific safety integrity level” on page 7-3.
- Please note that in order to achieve the specified PL, the sensor must have a medium level of diagnostic coverage (90% to 99%) and medium MTTFd. A high level of diagnostic coverage (> 99%) is recommended for the application according to PL d.
- Use sensors that can achieve the required safety integrity level.



To understand the change in state, please refer to “Example of correct and incorrect signal change” on page 7-13.

Device diagnostics and behavior of the module in the event of an error

Table 7-9 Two-channel equivalent cross-circuit monitoring disabled: supply through a clock output or external supply

Error type	Detection	Diagnostics	Loss of SF	Remark
<b>Error in the sensor</b>				
A contact will not open	Yes	Symmetry violation *)	No	The error is detected on a change in state, as the state only changes in one channel. – <b>Change in state from “1” to “0”:</b> The faulty input remains at “1”. A “0” is transmitted in the process data image of the affected inputs. – <b>Change in state from “0” to “1”:</b> A “0” is transmitted in the process data image of the affected inputs, as the faulty input was not previously set to state “0”.
A contact will not close	Yes	Symmetry violation	No	On a change in state from “0” to “1”, a “0” is transmitted in the process data image of the affected inputs, as only one channel reports this change in state.
Other errors (depending on the sensor)				<b>Please take into consideration all possible errors that can occur in the sensor.</b>
<b>Error in the wiring</b>				
<b>Interrupt</b>				
Cable interrupt between clock output or external supply and sensor	Yes	None	No	– <b>Behavior when the input is in state “1”:</b> The error is detected as a change in state from “1” to “0”. An unexpected change from “0” to “1” is possible (e.g., due to a loose contact). <b>Ensure that such a change in state cannot restart the system unintentionally.</b>
Cable interrupt between sensor and input	Yes	Symmetry violation	No	The error is detected in state “1” or on a change in state from “0” to “1”, as the state only changes in one channel.
<b>Cross circuit</b>				
Input to input	No	None	No	<b>An accumulation of errors can result in the loss of the safety function.</b>
Input to clock output	Yes	Symmetry violation	No	The error is detected on a change in state, as the state only changes in one channel. – <b>Change in state from “1” to “0”:</b> The faulty input remains at “1”. A “0” is transmitted in the process data image of the affected inputs. – <b>Change in state from “0” to “1”:</b> A “0” is transmitted in the process data image of the inputs, if the faulty input was not previously set to “0”.
Clock output to clock output	No	None	No	The error is not detected.
<b>Short circuit</b>				
Input to external 24 V	Yes	Symmetry violation	No	The error is detected on a change in state, as the state only changes in one channel. – <b>Change in state from “1” to “0”:</b> The faulty input remains at “1”. A “0” is transmitted in the process data image of the affected inputs. – <b>Change in state from “0” to “1”:</b> A “0” is transmitted in the process data image of the inputs, as the faulty input was not previously set to “0”.
Input to ground	Yes	None	No	The error is detected in state “1” or on a change in state from “0” to “1”, as the state only changes in one channel.
Clock output that is not clocked to external 24 V	No	None	No	The error is not detected.

Table 7-9 Two-channel equivalent cross-circuit monitoring disabled: supply through a clock output or external supply

Error type	Detection	Diagnostics	Loss of SF	Remark
Clock output to ground	Yes	Short circuit UTx ON	No	The error is detected as a change in state from "1" to "0". An unexpected change from "0" to "1" is possible (e.g., due to a loose contact). <b>Ensure that such a change in state cannot restart the system unintentionally.</b>  The error is also detected as a short circuit of the clock output. The affected clock output is disabled.
External 24 V to ground	Yes	None	No	The error is detected as a change in state from "1" to "0". An unexpected change from "0" to "1" is possible (e.g., due to a loose contact). <b>Ensure that such a change in state cannot restart the system unintentionally.</b>

\*) Only applies when symmetry monitoring is active



For all inputs that are parameterized without cross-circuit monitoring, cross circuits and short circuits are not detected by the device diagnostics, but only on a change in state of the input signals, as the state only changes in one channel. Early error detection, e.g., by testing the safety function at regular intervals, is required, as an accumulation of errors may result in the loss of the safety function.

**Typical parameterization**

Parameterization	Parameterized as	Remark
<b>Input xx channel 1/channel 2</b>		
Assignment	<b>Two-channel equivalent</b>	
Filter time ( $t_{Filter}$ )	3 ms	Application-specific
Symmetry	100 ms	Application-specific
Start inhibit due to symmetry violation	Disabled	Application-specific
Cross-circuit monitoring	<b>No cross-circuit monitoring</b>	

### 7.4.4 Two-channel equivalent: external supply (OSSD)

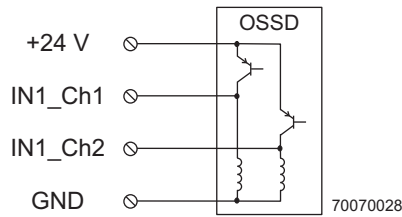

Figure 7-10 Two-channel equivalent assignment of inputs, external supply (OSSD)



**WARNING: Loss of functional safety due to parasitic voltages**  
 Connect the sensor ground directly to terminal point GND of the safety module. An external ground may not be used.

#### Basic specifications

<b>Sensor</b>	Two-channel OSSD output (with internal testing)
<b>Sensor supply</b>	External (OSSD sensor)
<b>Achievable SIL/SIL CL/Cat./PL</b>	SIL 3/SIL CL 3/Cat. 4/PL e



**WARNING: Loss of electrical and functional safety**

- To achieve the specified category, please refer to Section “Measures required to achieve a specific safety integrity level” on page 7-3.
- Please note that in order to achieve the specified PL, the sensor must have a high level of diagnostic coverage (> 99%) and high MTTFd.
- Use sensors that can achieve the required safety integrity level.

#### Device diagnostics and behavior of the module in the event of an error



To understand the change in state, please refer to “Example of correct and incorrect signal change” on page 7-13.

Table 7-10 Two-channel equivalent: external supply (OSSD)

Error type	Detection	Diagnosis	Loss of SF	Remark
<b>Error in the sensor</b>				
Channel failure	Yes	Symmetry violation *)	No	The error is detected on a change in state, as the state only changes in one channel. – <b>Change in state from “1” to “0”:</b> The faulty input remains at “1”. A “0” is transmitted in the process data image of the affected inputs. – <b>Change in state from “0” to “1”:</b> A “0” is transmitted in the process data image of the affected inputs, as the faulty input was not previously set to state “0”.
Other errors (depending on the sensor)				<b>Please take into consideration all possible errors that can occur in the sensor.</b>

Table 7-10 Two-channel equivalent: external supply (OSSD) [...]

Error type	Detection	Diagnostics	Loss of SF	Remark
<b>Error in the wiring</b>				
<b>Interrupt</b>				
Input (Cable interrupt between sensor and input)	Yes	Symmetry violation	No	The error is detected in state "1" or on a change in state from "0" to "1", as the state only changes in one channel.
Input (Cable interrupt between sensor and GND)	No	None	No	The error must be detected by the sensor. <b>The sensor must ensure that the safe state is entered in the event of an error.</b>
<b>Cross circuit</b>				
Input to input	No	None	Yes	The error must be detected by the sensor. <b>The sensor must ensure that the safe state is entered in the event of an error.</b>
Input to clock output	Yes	Symmetry violation	No	The error is detected on a change in state if the clock output is set to "1", as the state only changes in one channel.
<b>Short circuit</b>				
Input to 24 V	Yes	Symmetry violation	No	The error is detected on a change in state, as the state only changes in one channel.
Input to ground	Yes	Symmetry violation	No	The error is detected in state "1" or on a change in state from "0" to "1", as the state only changes in one channel.

\*) Only applies when symmetry monitoring is active

**Typical parameterization**

Parameterization	Parameterized as	Remark
<b>Input xx channel 1/channel 2</b>		
Assignment	<b>Two-channel equivalent</b>	
Filter time ( $t_{Filter}$ )	3 ms	Application-specific
Symmetry	100 ms	Application-specific
Start inhibit due to symmetry violation	Disabled	Application-specific
Cross-circuit monitoring	No cross-circuit monitoring	



Set the filter time for the input to a value greater than the width of the test pulse for the OSSD sensor.  
Cross-circuit detection must be disabled.

## 7.5 Two-channel non-equivalent assignment of safe inputs

For two-channel assignment of the safe inputs, two adjacent inputs are always used. This assignment is fixed and cannot be parameterized (see Section “Two-channel” on page 5-3).

For two-channel non-equivalent assignment, the state changes from “0” to “1” only when input INx\_Ch1 changes state from “0” to “1” and input INx\_Ch2 changes state from “1” to “0”. If symmetry monitoring is enabled and the state at both inputs does not change within the parameterized time, a diagnostic message is generated.

The state is active when the state of the signal at channel 1 is equal to “1” and the signal at channel 2 is equal to “0”.



Cross circuits between different inputs can only be detected if the input signals are supplied by different clock outputs.



Please note that if a delayed change in state at one of the two inputs causes the safety switch to be switched on again, this can result in delayed transmission of state “1” in the process data image of the inputs (e.g., due to a loose contact).

### Example of correct and incorrect signal change

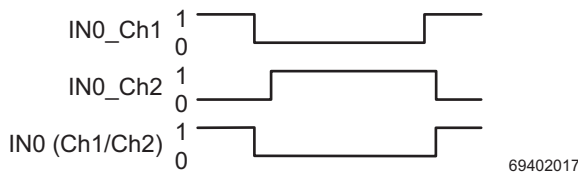

Figure 7-11 **Correct** signal change

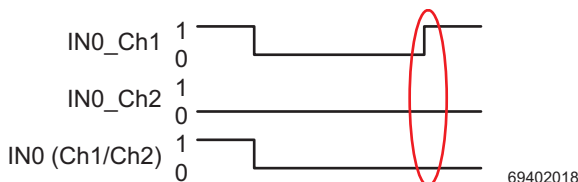

Figure 7-12 **Error** during signal change

In Figure 7-12, the condition that both signals must be in the opposite state before the change in state is not met. In this case, diagnostic message 018x<sub>hex</sub> is generated.

Key for Figure 7-5 and Figure 7-6

IN0_Ch1	Signal sequence at input 0 channel 1
IN0_Ch2	Signal sequence at input 0 channel 2
IN0 (Ch1/Ch2)	Safety-related signal for two-channel input 0 channel 1 and channel 2 at the safe controller (PROFIsafe) or the configurable safety module (SafetyBridge)

**State evaluation**

The module evaluates the states of the inputs and transmits the result to the safe controller (PROFIsafe) or the configurable safety module (SafetyBridge).

In the process data image of the safe inputs:

- A "1" is transmitted if a "1" signal is present at channel 1 of the input and a "0" signal is present at channel 2 of the input **and** no error has been detected and the conditions are met for a change in state according to Figure 7-12.
- A "0" is transmitted in all other cases.

**7.5.1 Notes about errors for two-channel non-equivalent assignment of safe inputs**

For the following examples, please note the resulting behavior in the event of an error:



**Note about cross circuits**

- The **cross circuit** error results in the transmission of the safe state in the process data image of the affected inputs.  
Remove the error and then acknowledge the message.  
Acknowledging the diagnostic message deletes the message and activates the input. The states at the input are detected immediately. **In your safe application program, ensure that the system cannot be restarted unintentionally following acknowledgment of the diagnostic message.**
- Please observe the maximum failure detection time of 64 ms.  
Exceptions in the failure detection time are indicated in the tables.  
If a "1" signal is present at the input and an error occurs, a maximum of 64 ms elapses until the error is detected. Within this time, another "1" can also be transmitted, even in the event of an error.  
Within the failure detection time (64 ms, maximum), the error can cause the state to change unexpectedly from "0" to "1".  
**Ensure that such a change in state cannot restart the system unintentionally.**



**Note about symmetry violation**

- The symmetry violation diagnostic message is only displayed if it was not disabled during parameterization of the affected input.
- **Start inhibit due to symmetry violation disabled:**  
The symmetry violation message does **not** result in the transmission of the safe state (see also "Symmetry/ start inhibit" on page 5-4).  
The message must be acknowledged. However, the current status of the inputs is displayed in the process data image of the inputs.
- **Start inhibit due to symmetry violation enabled:**  
The symmetry violation message results in the transmission of the safe state (see also "Symmetry/ start inhibit" on page 5-4).  
The message must be acknowledged. The current status of the inputs is displayed in the process data image of the inputs following acknowledgment.
- The message can be used to monitor the wear of the safety switch.



### 7.5.2 Two-channel non-equivalent with cross-circuit monitoring: supply through UT1 and UT2

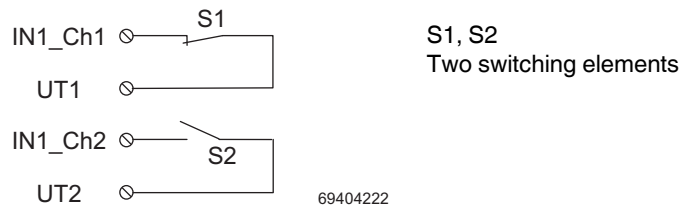

Figure 7-13 Two-channel non-equivalent assignment of inputs, supply through UT1 and UT2, cross-circuit monitoring enabled

#### Basic specifications

<b>Sensor</b>	Two-channel non-equivalent
<b>Sensor supply</b>	Internally through clock output UT1 <b>and</b> UT2; cross-circuit monitoring enabled
<b>Achievable SIL/SIL CL/Cat./PL</b>	SIL 3/SIL CL 3/Cat. 4/PL e



**WARNING: Loss of electrical and functional safety**

- To achieve the specified category, please refer to Section “Measures required to achieve a specific safety integrity level” on page 7-3.
- Please note that in order to achieve the specified PL, the sensor must have a high level of diagnostic coverage (> 99%) and high MTTFd.
- Use sensors that can achieve the required safety integrity level.



To understand the change in state, please refer to “Example of correct and incorrect signal change” on page 7-23.

**Device diagnostics and behavior of the module in the event of an error**

Table 7-11 Two-channel non-equivalent with cross-circuit monitoring: supply through UT1 and UT2

Error type	Detection	Diagnostics	Loss of SF	Remark
<b>Error in the sensor</b>				
A contact will not open	Yes	Symmetry violation *)	No	The error is detected, as the state only changes in one channel.
A contact will not close				
Other errors (depending on the sensor)				<b>Please take into consideration all possible errors that can occur in the sensor.</b>
<b>Error in the wiring</b>				
<b>Interrupt</b>				
Input (Cable interrupt between clock output and sensor or between sensor and input)	Yes	Symmetry violation	No	The error is detected on a change in state at the latest, as the state only changes in one channel.
<b>Cross circuit</b>				
Input to input	Yes	Cross circuit	No	The error is detected if the other input is set to "1".
Input to assigned clock output	Yes	Symmetry violation	No	The error is detected on a change in state, as the state only changes in one channel.
Input to non-assigned clock output	Yes	Cross circuit	No	See "Note about cross circuits" on page 7-24.
Clock output to clock output	Yes	Cross circuit	No	The error is detected for inputs, which are assigned to different clock outputs.
<b>Short circuit</b>				
Input to ground	Yes	None	No	The error is detected on a change in state at the latest, as the state only changes in one channel.
Clock output to ground	Yes	Short circuit UTx ON	No	The error is detected on a change in state at the latest, as the state only changes in one channel. The error is also detected as a short circuit of the clock output. The affected clock output is disabled.

\*) Only applies when symmetry monitoring is active



An error in input circuit INx\_Ch2 can only be detected in the event of a safety demand. Early error detection, e.g., by testing the safety function at regular intervals, is required, as an accumulation of errors may result in the loss of the safety function.

Typical parameterization

Parameterization	Parameterized as/value range	Remark
<b>Input xx channel 1/channel 2</b>		
Assignment	Two-channel non-equivalent	
Filter time ( $t_{\text{Filter}}$ )	3 ms	Application-specific
Symmetry	Disabled	Application-specific
Start inhibit due to symmetry violation	Disabled	Application-specific
Cross-circuit monitoring	Cross-circuit monitoring	

### 7.5.3 Two-channel non-equivalent cross-circuit monitoring disabled: supply through a clock output or external supply

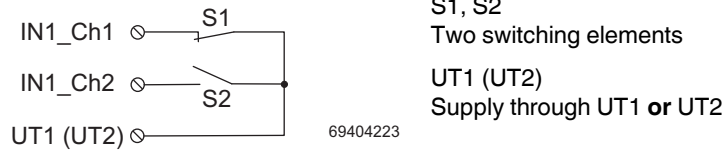

Figure 7-14 Two-channel non-equivalent assignment of inputs, supply through UT1 (or UT2) cross-circuit monitoring disabled

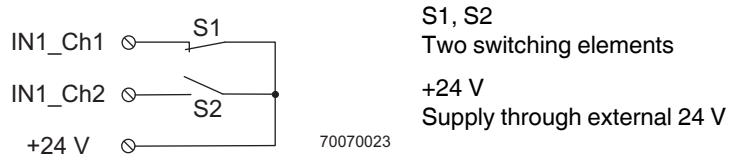

Figure 7-15 Two-channel non-equivalent assignment of inputs, external supply

#### Basic specifications

<b>Sensor</b>	Two-channel non-equivalent
<b>Sensor supply</b>	Internally through clock output UT1 (or UT2) (clocking disabled) <b>or</b> externally
<b>Achievable SIL/SIL CL/Cat./PL</b>	SIL 3/SIL CL 3/Cat. 3/PL d



**WARNING: Loss of electrical and functional safety**

- To achieve the specified category, please refer to Section “Measures required to achieve a specific safety integrity level” on page 7-3.
- Please note that in order to achieve the specified PL, the sensor must have a medium level of diagnostic coverage (90% to 99%) and medium MTTFd. A high level of diagnostic coverage (> 99%) is recommended for the application according to PL d.
- Use sensors that can achieve the required safety integrity level.



To understand the change in state, please refer to “Example of correct and incorrect signal change” on page 7-23.

**Device diagnostics and behavior of the module in the event of an error**

Table 7-12 Two-channel non-equivalent without cross-circuit monitoring: supply through a clock output or external supply

Error type	Detection	Diagnostics	Loss of SF	Remark
<b>Error in the sensor</b>				
A contact will not open	Yes	Symmetry violation	No	The error is detected, as the state only changes in one channel.
A contact will not close				
Other errors (depending on the sensor)				<b>Please take into consideration all possible errors that can occur in the sensor.</b>
<b>Error in the wiring</b>				
<b>Interrupt</b>				
Input (cable interrupt between clock output and sensor or between sensor and input)	Yes	Symmetry violation	No	The error is detected on a change in state at the latest, as the state only changes in one channel.
<b>Cross circuit</b>				
Input to input	Yes	Symmetry violation	No	The error is detected, as the state only changes in one channel.
Input to clock output	Yes	Symmetry violation	No	The error is detected, as the state only changes in one channel. – <b>Change in state from “1” to “0”:</b> The faulty input remains at “1”. A “0” is transmitted in the process data image of the affected inputs.
Clock output to clock output	<b>No</b>	None	No	The error is not detected.
<b>Short circuit</b>				
Input to external 24 V	Yes	Symmetry violation	No	The error is detected on a change in state at the latest, as the state only changes in one channel.
Input to ground	Yes	Symmetry violation	No	The error is detected in state “1” or on a change in state from “0” to “1”, as the state only changes in one channel.
Clock output to external 24 V	<b>No</b>	None	No	The error is not detected.
Clock output to ground	Yes	Short circuit UTx ON	No	The error is detected as a change in state from “1” to “0”. The error is also detected as a short circuit of the clock output. The affected clock output is disabled.
External 24 V to ground	Yes	Symmetry violation	No	The error is detected in state “1” or on a change in state from “0” to “1”, as the state only changes in one channel.

\*) Only applies when symmetry monitoring is active



Early error detection, e.g., by testing the safety function at regular intervals, is required, as an accumulation of errors may result in the loss of the safety function.

Typical parameterization

Parameterization	Parameterized as/value range	Remark
<b>Input xx channel 1/channel 2</b>		
Assignment	<b>Two-channel non-equivalent</b>	
Filter time ( $t_{Filter}$ )	3 ms	Application-specific
Symmetry	100 ms	Application-specific
Start inhibit due to symmetry violation	Enabled	Application-specific
Cross-circuit monitoring	No cross-circuit monitoring	

## 8 Startup and validation

### 8.1 Initial startup

To start up, proceed as described in Table 8-1.

Table 8-1 Steps for startup

Step	Relevant section and literature
Set the transmission speed and the mode.	Section "Setting the DIP switches" on page 4-2
Set the protocol/address.	Section "Setting the DIP switches" on page 4-2
Install the safety module within the Inline station.	Section "Assembly, removal, and electrical installation" on page 4-1
Connect the bus system and supply voltage cables to the Inline station.	IB IL SYS PRO UM E user manual (INTERBUS), IL SYS INST UM E or documentation for the bus coupler
Wire the inputs according to your application.	Section "Assembly, removal, and electrical installation" on page 4-1 Section "Inline potential and data routing, and Inline plugs" on page 3-1 User manuals for the function blocks used
Before applying the operating voltage: <ul style="list-style-type: none"> <li>– Ensure that there are no wiring errors (e.g., cross circuit or short circuit) or grounding errors by testing with a multimeter.</li> <li>– Check whether the ground connection is safe.</li> </ul>	
Connect the required voltages to the Inline station.	IB IL SYS PRO UM E user manual (INTERBUS), IL SYS INST UM E or documentation for the bus coupler
Once the operating voltage has been applied: <ul style="list-style-type: none"> <li>– If possible, measure the wave form of the voltages to ensure that there are no deviations.</li> <li>– Measure the input voltages on the module to ensure that they are in the permissible range.</li> <li>– Use the LEDs on the module to check that the module starts up without any errors.</li> </ul>	
Check the mounting and installation.	Checklist "Assembly and electrical installation" on page C-4
Carry out the necessary parameterization.	Section "Parameterization of the safety module" on page 5-1 Documentation for the configurable safety module used (SafetyBridge) Documentation for the controller used (PROFIsafe)

Table 8-1 Steps for startup [...]

Step	Relevant section and literature
Program the safety function.	User manuals for the function blocks used Documentation for the configurable safety module used (SafetyBridge) Documentation for the controller used (PROFIsafe)
For PROFIsafe: when verifying the safety function, check whether the F_iPar_CRC parameter is greater than 0 for all devices. If not, modify the settings.	Checklist "Validation" on page C-6 Quick start guide for configuring Inline modules with safe inputs or outputs under PROFIsafe on your controller
Perform a function test and validation. Check whether the safety function responds as planned during programming and parameterization.	Checklist "Validation" on page C-6

When connecting the supply voltages, use the diagnostic and status indicators to check whether the module has started up correctly or whether any errors are indicated. For instructions on how to proceed in the event of an error, please refer to Section "Errors: messages and removal" on page 9-1.



## 8.2 Restart after replacing a safety module

### 8.2.1 Replacing a safety module

**WARNING: Unintentional machine startup**

Do not assemble or remove the module while the power is connected.

Before assembling or removing the module, disconnect the power to the module and the entire Inline station and ensure that it cannot be switched on again.

Make sure the entire system is reassembled before switching the power back on.

Observe the diagnostic indicators and any diagnostic messages.

The system may only be started provided neither the station nor the system poses a hazard.

If replacing a module, proceed as described for assembly and removal (see Section “Assembly, removal, and electrical installation” on page 4-1).

Ensure that the new safety module is mounted at the correct position in the local bus. The new module must meet the following requirements:

- Same device type
- Same or later version

### 8.2.2 Restart

Once the safety module has been replaced, proceed as described for initial startup (see Section “Initial startup” on page 8-1).

The parameterization of the previous module remains the same and is transmitted to the new module when the system is started.

Plug the Inline plugs into the correct connections.

Perform a function test after replacing the module.

## 8.3 Validation

Carry out a safety validation every time you make a safety-related modification to the SafetyBridge or PROFIsafe system.

When validating your individual EUC, check the assignment of the sensor connections.

Determine whether:

- The correct safe sensors are connected to the safety module
- The safety module has been parameterized correctly
- The variables used in your application program have been linked to the safe sensors correctly

Perform a function test and error simulation.

Please observe the checklist “Validation” on page C-6 during validation.

## 9 Errors: messages and removal

Depending on the error type, errors that are diagnosed are displayed via the local diagnostic indicators and/or transmitted to the safe controller (PROFIsafe) or the configurable safety module (SafetyBridge) as diagnostic messages.

The tables below provide an overview of the diagnosed errors, their causes, effects, and possible measures for error removal.

For SafetyBridge, please also refer to the documentation for the configurable safety module used.

For every error that occurs, the cause of the error must first be removed. If necessary, the error is then acknowledged. Errors that must be acknowledged are indicated in the “Acknowledgment” column in the tables below.



If error codes are indicated by the system, which do not appear in the tables below, please contact Phoenix Contact.

### Error removal

To remove the cause of an error, please proceed as described in the “Solution” column in the tables below.

### Error acknowledgment

Instructions on how to acknowledge an error can be found in Section “Acknowledging an error” on page 9-8.

### Module replacement following an error

If in the event of failure the safety module is replaced, please proceed as described in Section 4, “Assembly, removal, and electrical installation” and Section “Restart after replacing a safety module” on page 8-3.

**Notes on the tables below**

The error code of a diagnostic message consists of the code for the error cause and the code for the error location.

**Structure of the error code**

Error code	
Code for error cause	Code for error location
E.g.: 012	x

**Error code**

The error code is specified in Table 9-1 and onwards.

**Error location**

In the error code specified, “x” specifies the location of the error. The value range for “x” is specified in the relevant row of the table.

For some errors a single channel is specified as the error location (e.g., IN0\_Ch1).

Some errors only occur for inputs/outputs parameterized for two-channel operation. Here, the channel pair is specified as the error location (e.g., IN0\_Ch1&2).

**Example:**

Safe input errors (Table 9-1)

Error cause	Error code (hex)
Cross circuit	012x
x = 0 ... 7: IN0_Ch1 ... IN7_Ch1; x = 8 ... F: IN0_Ch2 ... IN7_Ch2	

**012x** Cross circuit

**012x** Error location

This means, for example:

**0122** Cross circuit at IN2\_Ch1 (input 2 channel 1)

**012A** Cross circuit at IN2\_Ch2 (input 2 channel 2)

**LED**

The “LED” column specifies which local diagnostic LEDs indicate the error.

**Acknowledgment**

Errors that must be acknowledged are indicated with “Yes” in the “Acknowledgment” column. Special conditions for re-enabling an input or the module are specified in brackets [e.g., Yes (1)] in the “Acknowledgment” column and explained below the relevant table.

## 9.1 Safe digital input errors

Table 9-1 Safe digital input errors

Error cause	Error code (hex)	LED	Remark	Effect	Solution	Acknowledgment
<b>Cross circuit</b> x = 0 ... 7: IN0_Ch1 ... IN7_Ch1; x = 8 ... F: IN0_Ch2 ... IN7_Ch2	<b>012x</b>	–	Cross circuit with another input or with a clock output	Affected input is in the safe state	Check sensor Check clock outputs Check plug and cabling	Yes (2)
<b>Symmetry violation</b> x = 0 ... 7: IN0_Ch1&2 ... IN7_Ch1&2	<b>013x</b>	–	Not safety-related. Only for inputs parameterized for two-channel operation; used to evaluate the contacts of connected switches. State change in both channels takes longer than the value parameterized for symmetry.  This message can also be triggered by a cross circuit/short circuit.	“Start inhibit due to symmetry violation” is disabled: inputs continue to be detected and their states transmitted to the safe controller (PROFIsafe) or a configurable safety module (SafetyBridge)  “Start inhibit due to symmetry violation” is enabled: affected input is in the safe state	Check whether the message was triggered by a short circuit/cross circuit  If not: Check value for symmetry Check switches Replace switches during next maintenance. Activate connected I/O devices once (e.g., activate and unlock emergency stop).	Yes (4)
<b>Hardware fault</b> x = 0 ... 7: IN0_Ch1 ... IN7_Ch1; x = 8 ... F: IN0_Ch2 ... IN7_Ch2	<b>014x</b>	–		All module inputs are in the safe state	Power up with error-free selftest Exchange	Yes (3)
<b>Hardware fault</b>	<b>0170</b>	–		All module inputs are in the safe state	Power up with error-free selftest Exchange	Yes (3)
<b>Error during signal change</b> x = 0 ... 7: IN0_Ch1&2 ... IN7_Ch1&2	<b>018x</b>	–	Only for inputs parameterized for two-channel operation; implausible signal change at indicated input pair	Affected inputs in the safe state	Set both inputs to the safe state	Yes (1)

**Acknowledgment: yes (1)** Acknowledging the diagnostic message deletes the message.

**Acknowledgment: yes (2)** Acknowledging the diagnostic message deletes the message and activates the input. The states at the input are detected immediately. In your safe application program, ensure that the system cannot be restarted unintentionally following acknowledgment of the diagnostic message.

**Acknowledgment: yes (3)** Acknowledging the diagnostic message deletes the message. The module can only be re-started following power up and error-free selftest.

**Acknowledgment: yes (4)** “Start inhibit due to symmetry violation” is disabled:  
Acknowledging the diagnostic message deletes the message.  
“Start inhibit due to symmetry violation” is enabled:  
Acknowledging the diagnostic message deletes the message and activates the disabled inputs again.

## 9.2 Clock output UT1 and UT2 errors

Table 9-2 Clock output errors

Error cause	Error code (hex)	LED	Remark	Effect	Solution	Acknowledgment
<b>Short circuit or overload</b> x = 0: Clock output UT1; x = 8: Clock output UT2	<b>01Ex</b>	UT1 or UT2 ON		Affected clock output is disabled. Assigned inputs are set to "0".	Check plug and cabling (acknowledge error at all inputs, if necessary)	Yes (1)

### Acknowledgment: yes (1)

Acknowledging the diagnostic message deletes the message and re-enables the clock output and the assigned inputs. In your safe application program, ensure that the system cannot be restarted unintentionally following acknowledgment of the diagnostic message.



The clock outputs are also switched on and monitored when not parameterized. If a short circuit occurs at a clock output when it is in this state, the clock output is switched off. To exit the error, parameterize the device and acknowledge the error message.

## 9.3 Supply voltage errors

Table 9-3 Supply voltage  $U_M$  errors

Error cause	Error code (hex)	LED	Remark	Effect	Solution	Acknowledgment
<b>Undervoltage <math>U_M</math></b>	<b>01F0</b>	UM flashing	$U_M$ below the permissible voltage range	All module inputs are in the safe state	Check supply voltage level and correct Check supply line length and load	Yes (1)

### Acknowledgment: yes (1)

Acknowledging the diagnostic message deletes the message and activates the inputs.

### Undervoltage at $U_M$ :

Supply voltage  $U_M$  is measured. If  $U_M < 17\text{ V}$ , a diagnostic message is generated.

## 9.4 Parameterization errors

Table 9-4 Parameterization errors

Error cause	Error code (hex)	LED	Remark	Effect	Solution	Acknowledgment
<b>Incorrect parameterization</b>	See Table 9-5	FS (flashing)	Each input and clock output is parameterized individually	Module is in the safe state	Check and correct parameterization.	–

In order to determine what type of parameterization error has occurred, use the corresponding software to access the safe controller (PROFIsafe) or the standard control system (SafetyBridge) online and read the error.

For example, with the SAFETYPROG software and INTERBUS-Safety proceed as follows:

- Using the SAFETYPROG software, access the safe controller online.
- Click on the “SafePLC” button.
- Click on “Errors” in the window that opens.  
The errors can now be read.
- In the message window, switch to the “SafePLC Errors” tab.  
The device-specific error code is displayed in decimal notation.

Table 9-5 Parameterization errors

Error code		Short description	Solution
(hex)	(dec)		
<b>034x</b> x = 0 ... 7: IN0_Ch1&2...IN7_Ch1&2	<b>832:</b> IN0_Ch1&2 : <b>839:</b> IN7_Ch1&2	The setting for the symmetry monitoring of related inputs is not the same.	Inputs that are parameterized for two-channel operation must have the same symmetry settings.  Correct values and resend parameter data to the module.
<b>035x</b> x = 0 ... 7: IN0_Ch1 ... IN7_Ch1; x = 8 ... F: IN0_Ch2 ... IN7_Ch2	<b>848:</b> IN0_Ch1 : <b>855:</b> IN7_Ch1; <b>856:</b> IN0_Ch2 : <b>863:</b> IN7_Ch2	The value for symmetry monitoring is outside the permissible range.	Correct value and resend parameter data to the module.

## 9.5 General errors

Table 9-6 General errors

Error cause	Error code (hex)	LED	Remark	Effect	Solution	Acknowledgment
Device temperature at critical value	01F2			Immediate shut-down. Further temperature increase causes the module to switch to the safe state.	Check and adapt: <ul style="list-style-type: none"> <li>– Ambient conditions</li> <li>– Derating</li> <li>– Switching frequency</li> </ul>	Yes (1)
Error due to receipt of an unexpected message	01F3		Error due to receipt of an unexpected message while acknowledging a diagnostic message.  The device firmware handles this diagnostic message with the highest priority. Only when this message has been acknowledged correctly are other errors indicated (if present).	The acknowledgment process, during which an unexpected message was received, is aborted. The corresponding error remains in the error memory. Diagnostic message 01F3 is indicated.	Check and adapt the assignment of the diagnostic and confirmation variables at the corresponding function block (see documentation for the controller used).  Acknowledge diagnostic message 01F3 so that the next message from the error memory can be indicated.	Yes (1)
Hardware fault		FS ON	Error in the logic area	Module is in the safe state	Exchange	

**Acknowledgment: yes (1)** Acknowledging the diagnostic message deletes the message.

## 9.6 PROFIsafe errors

In addition to the module errors specified, the following errors can occur:

- PROFIsafe system errors: these messages can be found in Section “Diagnostic messages for parameter errors” on page B-3.
- PROFIBUS or PROFINET system errors: for information on these errors, please refer to the documentation for the system used.



## 9.7 Acknowledging an error

### 9.7.1 Acknowledging an error for SafetyBridge

An IB IL 24 PSDI 16-PAC error is acknowledged completely via the configurable safety module.



For instructions on error acknowledgment, please refer to the documentation for the configurable safety module used.

### 9.7.2 Acknowledging an error for PROFIsafe

- Remove the cause of the error.
- Then acknowledge the diagnostic message.



For instructions on error acknowledgment, please refer to the documentation for the controller used.



**WARNING: Acknowledgment may result in a hazardous system state**

With the exception of a few special cases, the acknowledgment of an error immediately returns the safe input to the operating state. Before acknowledging an error you must, therefore, make sure that the acknowledgment will not cause the machine to switch to a dangerous state.

When planning the machine or system, make sure that acknowledgment is only possible if the danger zone is visible.

If in the event of failure the safety module is replaced, please proceed as described in Section 4, "Assembly, removal, and electrical installation" and Section 8.2, "Restart after replacing a safety module".

# 10 Maintenance, repair, decommissioning, and disposal

## 10.1 Maintenance

The device is designed in such a way that maintenance work is not required during the duration of use. However, depending on the application and connected I/O devices it may be necessary to test the function of the I/O devices and the safety chain at regular intervals.

The duration of use of the module is 20 years.

Repeat testing within this time is not required.

Carry out maintenance of connected I/O devices (e.g., light grid) according to the relevant manufacturer specifications.

## 10.2 Repair

Repair work may not be carried out on the safety module. In the event of an error, send the module to Phoenix Contact.

It is strictly prohibited to open the safety module. In order to prevent the manipulation of the module and to detect the unauthorized opening of the module, a security seal is applied to the module. This security seal is damaged in the event of unauthorized opening. In this case, the correct operation of the safety module can no longer be ensured.

## 10.3 Decommissioning and disposal

The machine or system manufacturer specifies the procedure for decommissioning. Decommissioning may only take place according to these specified procedures.

When decommissioning a SafetyBridge or PROFIsafe system or parts thereof, ensure that the safety modules used:

- Are correctly reused in another system  
In this case, please observe the storage and transport requirements according to the technical data (see “IB IL 24 PSDI 16-PAC” on page 1-2).
- Or**
- Are disposed of according to the applicable environmental regulations, and in this case can never be reused

# 1 Technical data and ordering data

## 1.1 System data

### 1.1.1 SafetyBridge



For the system data for your system, please refer to the corresponding documentation for the controller used.

### 1.1.2 PROFIsafe

PROFIsafe	
PROFIsafe profile	2.4
DAT	2 ms

For the system data for your system, please refer to the corresponding documentation for the controller used.

## 1.2 IB IL 24 PSDI 16-PAC

General data	
Housing dimensions (width x height x depth)	48.8 mm x 141 mm x 71.5 mm
Weight (with plugs)	225 g
Operating mode	
SafetyBridge	Process data mode with 4 words
PROFIsafe	Process data mode with 4 words and 1 word PCP (internal use)
Transmission speed (INTERBUS/local bus)	500 kbaud or 2 Mbaud
Ambient temperature	
Operation	-25°C to +55°C
Storage/transport	-25°C to +70°C
Humidity	
Operation	75% on average, 85% occasionally (no condensation)
	In the range from -25°C to +55°C appropriate measures against increased humidity must be taken.
Storage/transport	75% on average; 85% occasionally (no condensation)
	For a short period, slight condensation may appear on the outside of the housing.
Air pressure	
Operation	80 kPa to 108 kPa (up to 2000 m above sea level)
Storage/transport	66 kPa to 108 kPa (up to 3500 m above sea level)
Degree of protection	IP20
Housing material	Plastic PBT, self-extinguishing (V0)
Air and creepage distances	According to IEC 60664-1
Protection class	III (PELV)
Gases that may endanger functions according to DIN 40046-36, DIN 40046-37	
Sulfur dioxide (SO <sub>2</sub> )	Concentration 10 ±0.3 ppm Ambient conditions: – Temperature 25°C ±2 K – Humidity 75% ±5% – Test duration 10 days
Hydrogen sulfide (H <sub>2</sub> S)	Concentration 1 ±0.3 ppm Ambient conditions: – Temperature 25°C ±2 K – Humidity 75% ±5% – Test duration 4 days
Resistance of housing material to termites	Resistant
Resistance of housing material to fungal decay	Resistant
Ambient compatibility	Not resistant to chloroform
Connection data for Inline plugs	
Connection method	Spring-cage terminal terminals
Conductor cross section	0.2 mm <sup>2</sup> to 1.5 mm <sup>2</sup> (solid or stranded), 24 - 16 AWG

### Mechanical requirements

Vibration according to IEC 60068-2-6	Operation: 2g, Criterion A
Shock according to IEC 60068-2-27	15g over 11 ms, Criterion A

### Safety characteristics according to IEC 61508/EN 61508

Achievable SIL	SIL 2 (single-channel) SIL 3 (two-channel) Depends on the parameterization and wiring (see Section "Connection options for sensors depending on the parameterization" on page 2-7 and Section "Connection examples for safe inputs" on page 7-1)
Probability of a dangerous failure on demand by the safety function (PFD)	SIL 2: 1% of $10^{-2}$ , maximum (corresponds to $1 \times 10^{-4}$ ) SIL 3: 1% of $10^{-3}$ , maximum (corresponds to $1 \times 10^{-5}$ )
Probability of a dangerous failure per hour for the entire module (PFH)	SIL 2: 1% of $10^{-6}$ , maximum (corresponds to $1 \times 10^{-8}$ ) SIL 3: 1% of $10^{-7}$ , maximum (corresponds to $1 \times 10^{-9}$ ) Depends on the parameterization (see Table 7-4 on page 7-3)
Hardware fault tolerance (HFT) of the module	1
Permissible duration of use	20 years

### Safety characteristics according to DIN EN 62061

Achievable SIL claim limit	SIL CL = SIL 2 (single-channel) SIL CL = SIL 3 (two-channel) Depends on the parameterization and wiring (see Section "Connection options for sensors depending on the parameterization" on page 2-7 and Section "Connection examples for safe inputs" on page 7-1)
Safe failure fraction (SFF)	99%
Probability of a dangerous failure per hour for the entire module (PFH)	SIL 2: 1% of $10^{-6}$ , maximum (corresponds to $1 \times 10^{-8}$ ) SIL 3: 1% of $10^{-7}$ , maximum (corresponds to $1 \times 10^{-9}$ ) Depends on the parameterization (see Table 7-4 on page 7-3)
Hardware fault tolerance (HFT) of the module	1
Permissible duration of use	20 years

### Safety characteristics according to EN ISO 13849-1

Achievable performance level	PL e (two-channel) PL d (single-channel) Depends on the parameterization and wiring (see Section "Connection options for sensors depending on the parameterization" on page 2-7 and Section "Connection examples for safe inputs" on page 7-1)
Diagnostic coverage (DC)	99%
Mean time to dangerous failure (MTTFd)	For single-channel assignment: 76 years For two-channel assignment: 100 years

### Supply voltage $U_L$ (logic)



The safety terminal is supplied with communications power via the bus coupler or a designated power terminal in the station. Potential routing is used for the communications power in the Inline station. For the technical data, please refer to the data sheet for the bus coupler or power terminal used.

Current consumption	190 mA, maximum
---------------------	-----------------

**Supply voltage  $U_M$  (sensors, clock outputs)**



The safety terminal is supplied with main voltage  $U_M$  via the bus coupler or a power terminal in the station. Potential routing is used for the main voltage in the Inline station. For the technical data, please refer to the data sheet for the bus coupler or power terminal used.



**WARNING: Loss of the safety function when using unsuitable power supplies**

Only use power supplies according to EN 50178/VDE 0160 (PELV).

Nominal voltage	24 V DC according to EN 61131-2 and EN 60204
Tolerance	-15%/+20% including an entire AC voltage component with peak value of 5%
Ripple	3.6 V <sub>PP</sub>
Permissible voltage range	19.2 V DC to 30.0 V DC, ripple included
Current consumption	10 mA, typical (plus current consumption of the inputs when supplied through the clock outputs plus current consumption of the connected initiators when supplied through the clock outputs)
Permissible interruption time	10 ms (output voltage of the clock outputs can fail)
Surge protection	Yes (in the bus coupler/power terminal)
Protection against polarity reversal	Yes (in the bus coupler/power terminal)



**NOTE: Module damage due to polarity reversal**

Polarity reversal places a burden on the electronics and, despite protection against polarity reversal, can damage the module. Therefore, polarity reversal must be prevented.

Undervoltage detection	Yes, at 17 V, approximately
Diagnostic indicators	Green $U_M$ LED (see "Local diagnostic and status indicators" on page 2-8)
External fuse protection	8 A slow-blow, maximum



**NOTE: Module damage in the event of overload**

The power supply unit must be able to supply four times (400%) the nominal current of the external fuse.

**Safe digital inputs**

Number	8 two-channel or 16 single-channel
Input design	According to the requirements of EN 61131-2 Type 3
Supply	Via clock outputs UT1 and UT2 or external supply
Input current	Approximately 2.7 mA at 24 V, typical
Maximum permissible current for "0"	1.5 mA
Minimum permissible current for "1"	2.0 mA
Permissible input voltage range	-3 V to +30 V
Voltage range for "0"	-3 V to +5 V
Voltage range for "1"	11 V to 30 V
Maximum switching frequency	10 Hz
Filter time $t_{Filter}$	Can be parameterized; see Section "Parameterization of the safe inputs" on page 5-3
Minimum filter time	3 ms, accuracy +0 ms, -0.5 ms

### Safe digital inputs [...]

Processing time of the input	$t_{IN} = t_{Filter} + t_{FW}$ (see "Processing time of the input $t_{IN}$ in the event of a safety demand" on page 5-6)
Simultaneity	100%
Symmetry evaluation	Yes, can be parameterized, accuracy $\pm 25\%$
Derating	No
Permissible cable lengths	500 m from the clock output to the safe input (total based on forward and return path)
Status indicators	One green LED per input (see "Local diagnostic and status indicators" on page 2-8)



The switching state of the inputs is constantly monitored. In the event of an error, e.g., if a component fails, the error is indicated at the safe controller (PROFIsafe) or a configurable safety module (SafetyBridge).

### Clock outputs

Number	2
Supply	From $U_M$
Maximum switching current	0.2 A short-circuit and overload protection
Saturation voltage	$U_M - 1 \text{ V}$
Simultaneity	100%
Derating	No
Permissible cable lengths	The total length of the connected cables must not exceed 500 m per clock output
Status indicators	None
Diagnostic indicators	One red LED for each (UT1, UT2) (see "Local diagnostic and status indicators" on page 2-8)

### Power dissipation

If $U_M = 24 \text{ V}$ , no input is set, without load at clock outputs UT1 and UT2	1200 mW
If $U_M = 24 \text{ V}$ , 16 inputs are set, load at clock outputs UT1 and UT2 is 100 mA each	2600 mW

### Electrical isolation/isolation of the voltage areas



To provide electrical isolation between the logic level and the I/O area, it is necessary to supply the bus coupler and this safety module from separate power supply units. Interconnection of the power supply units in the 24 V area is not permitted. (See also user manual.)

### Separate potentials in the system consisting of bus coupler/power terminal and safety module

#### - Test distance

5 V supply incoming remote bus/7.5 V supply (bus logic)	500 V AC, 50 Hz, 1 min.
5 V supply outgoing remote bus/7.5 V supply (bus logic)	500 V AC, 50 Hz, 1 min.
7.5 V supply (bus logic)/24 V supply $U_M$ , FE	500 V AC, 50 Hz, 1 min.

#### - Test voltage



The isolating distance between  $U_M$  and FE is covered by a varistor.



**Approvals**

For the latest approvals, please visit [www.phoenixcontact.net/products](http://www.phoenixcontact.net/products).

**1.3 Conformance with EMC Directive**

**Conformance with EMC Directive 2004/108/EC**

**Noise immunity test according to DIN EN 61000-6-2**

Electrostatic discharge (ESD)	EN 61000-4-2 (IEC 61000-4-2)	Criterion B 6 kV contact discharge, 8 kV air discharge
Electromagnetic fields	EN 61000-4-3 (IEC 61000-4-3)	Criterion A, field strength 10 V/m
Fast transients (burst)	EN 61000-4-4 (IEC 61000-4-4)	Criterion B, test voltage 2 kV
Surge voltage	EN 61000-4-5 (IEC 61000-4-5)	Test intensity 2, Criterion B DC supply lines: 0.5 kV/0.5 kV (symmetrical/asymmetrical) Signal lines: 1.0 kV/2.0 kV (symmetrical/asymmetrical)
Conducted interference	EN 61000-4-6 (IEC 61000-4-6)	Criterion A, test voltage 10 V

**Noise emission test according to DIN EN 61000-6-4**

Noise emission	EN 55011	Class A, industrial applications
----------------	----------	----------------------------------

**1.4 Ordering data**

**1.4.1 Ordering data: safety module**

Description	Type	Order No.	Pcs. / Pkt.
Inline module with safe digital inputs	IB IL 24 PSDI 16-PAC	2700994	1

## 1.4.2 Ordering data: documentation

Description	Type	Order No.	Pcs. / Pkt.
<b>Inline</b>			
User manual Automation terminals of the Inline product range		-	-
User manual Configuring and installing the INTERBUS Inline product range		-	-
<b>SafetyBridge</b>			
User manual Inline module with integrated safety logic and safe digital outputs			-
<b>PROFIsafe</b>			
Quick start guide Configuring Inline modules with safe inputs or outputs under PRO- FIsafe on a SIMATIC® S7 controller			1
Specification PROFIsafe - Profile for Safety Technology on PROFIBUS DP and PROFINET IO, Version 2.4, February 2007	See <a href="http://www.profisafe.net">http://www.profisafe.net</a>		
<b>INTERBUS (general)</b>			
User manual General introduction to the INTERBUS system			1
User manual Configuring and installing INTERBUS		-	-
User manual INTERBUS Diagnostics Guide		-	-
User manual Firmware services and error messages			1
Data sheet Addressing INTERBUS		-	-
<b>Documentation for software</b>			
Quick start guide SAFETYPROG			1
Quick start guide Config+		-	-
Quick start guide PC Worx		-	-



Make sure you always use the latest documentation. It can be downloaded at [www.phoenixcontact.net/products](http://www.phoenixcontact.net/products).



Documentation for PROFIsafe, PROFIBUS, and PROFINET is available on the Internet at [www.profibus.com/pall/meta/downloads](http://www.profibus.com/pall/meta/downloads).

# A Appendix: PROFIsafe terms used in the manual

Some of the terms that are used in connection with PROFIsafe in this manual are described below.

A definition of PROFIsafe terms is also provided in the PROFIsafe profile.

<b>CRC</b>	Cyclic Redundancy Check  A cyclic redundancy check is used to verify the validity of the process data contained in the safety telegram, check whether the assigned address relationships are correct, and verify the safety-related parameters. This value is part of the safety telegram.										
<b>Consecutive number</b>	Consecutive number  Method for ensuring that the safe data is transmitted completely and in the correct order.										
<b>F-Parameter</b>	(According to PROFIsafe system description, Version 09, November 2007)  F-Parameters contain information for adapting the PROFIsafe layer to specific customer specifications and for checking the parameterization by means of a separate method (diverse). The main F-Parameters are:  <table><tr><td>F_S/D_Address (F-Address for short)</td><td>A unique address for F-Devices within a PROFIsafe island. The technology part of the F-Device compares the value with the address switch locally or with an assigned F-Address in order to check the authenticity of the connection.</td></tr><tr><td>F_WD_Time</td><td>Specifies the millisecond value for the watchdog timer. The timer monitors the time that elapses until the next valid PROFIsafe message is received.</td></tr><tr><td>F_SIL</td><td>Indicates the SIL that the user can expect from the relevant F-Device. It is compared with the manufacturer's specification that is stored locally.</td></tr><tr><td>F_iPar_CRC</td><td>A checksum that is calculated from all iParameters of the technology-specific part of the F-Device.</td></tr><tr><td>F_Par_CRC</td><td>A CRC signature, which is created via all F-Parameters and ensures error-free transmission of the F-Parameters.</td></tr></table>	F_S/D_Address (F-Address for short)	A unique address for F-Devices within a PROFIsafe island. The technology part of the F-Device compares the value with the address switch locally or with an assigned F-Address in order to check the authenticity of the connection.	F_WD_Time	Specifies the millisecond value for the watchdog timer. The timer monitors the time that elapses until the next valid PROFIsafe message is received.	F_SIL	Indicates the SIL that the user can expect from the relevant F-Device. It is compared with the manufacturer's specification that is stored locally.	F_iPar_CRC	A checksum that is calculated from all iParameters of the technology-specific part of the F-Device.	F_Par_CRC	A CRC signature, which is created via all F-Parameters and ensures error-free transmission of the F-Parameters.
F_S/D_Address (F-Address for short)	A unique address for F-Devices within a PROFIsafe island. The technology part of the F-Device compares the value with the address switch locally or with an assigned F-Address in order to check the authenticity of the connection.										
F_WD_Time	Specifies the millisecond value for the watchdog timer. The timer monitors the time that elapses until the next valid PROFIsafe message is received.										
F_SIL	Indicates the SIL that the user can expect from the relevant F-Device. It is compared with the manufacturer's specification that is stored locally.										
F_iPar_CRC	A checksum that is calculated from all iParameters of the technology-specific part of the F-Device.										
F_Par_CRC	A CRC signature, which is created via all F-Parameters and ensures error-free transmission of the F-Parameters.										
<b>F-CPU</b>	Failsafe control system, safe controller										
<b>F_Destination_Address</b>	F-Parameter; PROFIsafe destination address; address of the safe device (see also "F-Parameter")										
<b>F-I/O device</b>	Failsafe I/O device; safe input and/or output modules  Modules with integrated safety functions, which are approved for safety-related operation.										
<b>F-Slave</b>	Failsafe slave										
<b>F_Source_Address</b>	F-Parameter; PROFIsafe source address; address of the safe controller (see also "F-Parameter")										

<b>F-System</b>	<p>Failsafe system</p> <p>A failsafe system is a system that remains in the safe state or immediately enters a safe state when specific failures occur.</p>
<b>iParameter</b>	<p>Individual safety parameter of a device</p>
<b>Passivation</b>	<p>If the safety module (F-I/O device) detects an error, it switches the affected channel or all channels of the module to the safe state; the channels are then passivated. The detected errors are indicated at the safe controller.</p> <p>For a safe input module when the F-System is passivated, instead of the process values present at the safe inputs, substitute values (0) are provided for the safety program.</p> <p>For a safe output module when the F-System is passivated, instead of the output values provided by the safety program, substitute values (0) are transferred to the safe outputs.</p>
<b>PROFIsafe</b>	<p>Safety-related bus profile based on PROFIBUS DP or PROFINET. It defines the communication between a safety program and the safe I/O device (F-I/O device) in a safe system (F-System).</p>
<b>PROFIsafe address</b>	<p>Each safe module has a PROFIsafe address. This address must be set on the safety module (F-I/O device) via DIP switches and then configured in the configuration tool for the safe controller used.</p>
<b>PROFIsafe monitoring time</b>	<p>Monitoring time for safety-related communication between the safe controller (F-CPU) and safe I/O device (F-I/O device).</p> <p>This time is parameterized in the F_WD_Time F-Parameter.</p>
<b>Consecutive number</b>	<p>See “Consecutive number”</p>

# B Appendix: F-Parameters and iParameters

## B 1 F-Parameters



The values indicated in italics in Table B-1 are preset by the system and cannot be modified manually.

Table B-1 Overview of the F-Parameters for the module

F-Parameter	Default value	Description
F_Source_Address	<i>Automatic</i>	The parameter uniquely identifies the PROFIsafe source address (controller address). The address is assigned automatically.
F_Destination_Address	<i>Automatic</i>	PROFIsafe destination address (address of the safe device). The address is assigned automatically. However, the value can be modified. Make sure that the value set under F_Destination_Address and the value that you have set via the 10-pos. DIP switch are the same. Value range: 1 ... 1022
F_WD_Time	150	Monitoring time in the safety module. A valid current safety telegram must arrive from the safe controller within the monitoring time. Otherwise, the safety module enters the safe state. The selected monitoring time must be sufficiently high for telegram delays to be tolerated by the communication, but still ensure a sufficiently fast error response in the event of an error (e.g., interruption in communication). Value range: 1 ... 65534, in 1 ms increments Unit: ms
F_SIL	<i>SIL 3</i>	Safety integrity (SIL according to IEC 61508) of the safety module  <div style="border: 1px solid black; padding: 5px; display: inline-block;">  <p><b>WARNING:</b> Safety functions up to SIL 3 can be achieved with the safety module. The safety integrity level that can actually be achieved depends on the parameterization, the structure of the sensor, and the cable installation (see "Connection examples for safe inputs" on page 7-1).</p> </div>
F_CRC_Length	<i>3-byte CRC</i>	This parameter transmits the length of the CRC2 code to be expected in the safety telegram to the safe controller.

Table B-1 Overview of the F-Parameters for the module

<b>F-Parameter</b>	<b>Default value</b>	<b>Description</b>
F_Block_ID	1	Parameter block type identification 1: the parameter block of the F-Parameters contains the F_iPar_CRC parameter.
F_Par_Version	1	Version number of the F-Parameter block. 1: valid for V2 mode
F_iPar_CRC	0	CRC checksum via the iParameters The value must be greater than 0. When verifying the safety function, check whether the F_iPar_CRC parameter is greater than 0 for all devices. If not, check the iParameters and the CRC checksum in the iParameter and F-Parameter.

## **B 2 iParameters**

The iParameters are individual device parameters. They include:

- Device parameters (see "Parameterization of the safe inputs" and "Parameterization of clock outputs UT1 and UT2")
- PST\_Device\_ID (10<sub>hex</sub> for IB IL 24 PSDI 16-PAC)
- F\_Destination\_Address (not included in the checksum calculation)

### **iPar\_CRC**

The device parameters are verified with a checksum: iPar\_CRC.

### **F\_Destination\_Address**

This address is the PROFIsafe address of the module. Make sure that it matches the switch position of the 10-pos. DIP switch.

## B 3 Diagnostic messages for parameter errors

### B 3.1 Diagnostic messages for F-Parameters and iParameters for PROFI-safe

Table B-2 F-Parameter parameter errors

Error code		Error cause	Solution
dec	hex		
64	40	The parameterized F_Destination_Address does not match the PROFI-safe address set on the safety module (F-Module).	Make sure that the PROFI-safe address of the safety module and the value in F_Destination_Address are the same.
65	41	Invalid parameterization of F_Destination_Address. Addresses 0000 <sub>hex</sub> and FFFF <sub>hex</sub> are not permitted.	Correct value.
66	42	Invalid parameterization of F_Source_Address. Addresses 0000 <sub>hex</sub> and FFFF <sub>hex</sub> are not permitted.	Correct value.
67	43	Invalid parameterization of F_WD_Time. A monitoring time of 0 ms is not permitted.	Correct value.
68	44	Invalid parameterization of F_SIL. The safety module (F-Module) cannot support the required SIL.	Use a device with the required SIL. The safety module achieves SIL 3, maximum.
69	45	Invalid parameterization of F_CRC_Length. The CRC length generated by the safety module (F-Module) does not match the required length.	Check device description.
70	46	Invalid F-Parameter record version. The safety module (F-Module) version does not match the required version.	Check device description. Only V2 mode permitted.
71	47	The checksum determined by the safety module (F-Module) via the PROFI-safe parameters (CRC1) does not match the CRC1 transmitted in the parameter telegram.	Check F-Parameters, repeat calculation.
255	4F	During active process data communication, a new F-Parameter block was received, which differs from the F-Parameter block currently used.  Incorrect type ID for the F-Parameter block (F_Block_ID).	Only send modified parameter data when process data communication is not active.  Check device description.

Table B-3 iParameter parameter errors

Error code (hex)	Error cause	Solution
03F2	iPar_CRC is incorrect	Check iParameters, repeat calculation.
03FA	iPar_CRC is not equal to F_iPar_CRC	Apply correct value.
03FB	PST_Device_ID is incorrect	Correct value (70 <sub>hex</sub> for IB IL 24 PSDI 16-PAC).
03FC	F_Destination_Address in the iParameters is incorrect	Correct value.  Make sure that the value set under F_Destination_Address and the value that you have set via the 10-pos. DIP switch are the same.

### B 3.2 Diagnostic messages for parameter errors for SafetyBridge

Table B-4 Parameter errors

SafetyBridge error code		Error cause	Solution
dec	hex		
1088	440	SafetyBridge: The parameterized SafetyBridge address does not match the address set on the safety module.	Make sure that the addresses are the same.
1089 ... 1094	441 ... 446	Internal error	Please contact Phoenix Contact.
1095	447	The configurable safety module detected a distortion in the configuration and parameter data record.	Attempt transmission again.  If the error occurs permanently, the data record in the controller is distorted. In this case, you can get SAFECONF to generate a new data record.



## C Appendix: checklists

The checklists listed in this section provide support during the planning, assembly and electrical installation, startup, parameterization, and validation of the IB IL 24 PSDI 16-PAC module.



These checklists may be used as planning documentation and/or as verification to ensure the steps in the specified phases are carried out carefully.

Archive the completed checklists to use as reference for recurring tests.

The checklists do not replace the validation, initial startup, and regular testing performed by qualified personnel.

The following section of a checklist shows an example of a completed checklist.

Checklist . . .				
<b>Device type/equipment identification</b>		IB IL 24 PSDI 16-PAC/BK20NA10		
<b>Version: HW/FW</b>	00/200	<b>Date</b>	January 17, 2008	
<b>Test engineer 1</b>	John Smith	<b>Test engineer 2</b>	Jane Brown	
<b>Remark</b>	System XXX has been checked for engine hood production			
<b>No</b>	<b>Requirement (mandatory)</b>	<b>Yes</b>	<b>Remark</b>	
.				
X	...	<input type="checkbox"/>		
<b>No</b>	<b>Requirement (optional)</b>	<b>Yes</b>	<b>No</b>	<b>Remark</b>
.				
Y	...	<input type="checkbox"/>	<input type="checkbox"/>	

Key:

Equipment identification	Enter the device type and/or the equipment identification for the relevant device.
Version: HW/FW	Enter the hardware and firmware version of the device (see Section “Structure of the safety module” on page 2-2).
Date	Enter the date on which you began to fill in this checklist.
Test engineer 1/2	Enter the names of the test engineers.
Remark	Enter a remark, if necessary.
Requirement (mandatory)	These requirements must be met for a safety application, in order to complete the relevant phase using the checklist.
Requirement (optional)	These requirements are optional. For points that are not met, please enter an appropriate remark in the relevant field.

## C 1 Planning

Checklist for planning the use of the safety module			
<b>Device type/equipment identification</b>			
<b>Version: HW/FW</b>		<b>Date</b>	
<b>Test engineer 1</b>		<b>Test engineer 2</b>	
<b>Remark</b>			
No	Requirement (mandatory)	Yes	Remark
1	Has the current module user manual been used as the basis for planning?	<input type="checkbox"/>	Revision:
2	Are the sensors approved for connection to the module (according to the technical data and parameterization options)?	<input type="checkbox"/>	
3	Has the voltage supply been planned according to the specifications for the protective extra-low voltage in accordance with PELV?	<input type="checkbox"/>	
4	Is external fuse protection of the module planned (according to the specifications in this user manual for supply voltage $U_M$ )?	<input type="checkbox"/>	
5	Are measures planned to prevent simple manipulation?	<input type="checkbox"/>	
6	Are measures planned to prevent plugs being mixed up?	<input type="checkbox"/>	
7	Are requirements for the sensors and cable installation observed according to the SIL/SIL CL/Cat./PL to be achieved and is the corresponding implementation planned?	<input type="checkbox"/>	
8	Are the specifications for the parameterization for each channel specified?	<input type="checkbox"/>	
9	Has it been ensured that any person intentionally starting hazardous movements has a direct view of the danger zone?	<input type="checkbox"/>	
10	Does the planned use correspond to the intended use?	<input type="checkbox"/>	
11	Are the ambient conditions observed according to the technical data?	<input type="checkbox"/>	
12	Have test intervals been defined?	<input type="checkbox"/>	

No	Requirement (optional)	Yes	No	Remark
13	Have the accessories to be used been planned according to the ordering data in this user manual (cables, plugs)?	<input type="checkbox"/>	<input type="checkbox"/>	
14	Have specifications for assembly and electrical installation been defined (e.g., EPLAN) and communicated to the relevant personnel?	<input type="checkbox"/>	<input type="checkbox"/>	
15	Have specifications for startup been defined and communicated to the relevant personnel?	<input type="checkbox"/>	<input type="checkbox"/>	
		Date		Signature (test engineer 1)
		Date		Signature (test engineer 2)

## C 2 Assembly and electrical installation

Checklist for assembly and electrical installation of the safety module				
<b>Device type/equipment identification</b>				
<b>Version: HW/FW</b>		<b>Date</b>		
<b>Test engineer 1</b>		<b>Test engineer 2</b>		
<b>Remark</b>				
No	Requirement (mandatory)	Yes		Remark
.				
1	Was assembly completed according to the specifications (specifications from the planning phase or according to the user manual)?	<input type="checkbox"/>		
2	Was the safety module installed in the control cabinet (IP54)?	<input type="checkbox"/>		
3	Do the cable cross sections correspond to the specifications?	<input type="checkbox"/>		
No	Requirement (optional)	Yes	No	Remark
.				
4	Is the transmission speed and the operating mode set correctly according to the specifications?	<input type="checkbox"/>	<input type="checkbox"/>	
5	Is the protocol/address set correctly according to the specifications?	<input type="checkbox"/>	<input type="checkbox"/>	
		Date		Signature (test engineer 1)
		Date		Signature (test engineer 2)

### C 3 Startup and parameterization

Checklist for startup and parameterization of the safety module				
<b>Device type/equipment identification</b>				
<b>Version: HW/FW</b>		<b>Date</b>		
<b>Test engineer 1</b>		<b>Test engineer 2</b>		
<b>Remark</b>				
No	Requirement (mandatory)	Yes	Remark	
1	Was startup completed according to the specifications (specifications from the planning phase or according to the user manual)?	<input type="checkbox"/>		
2	During startup, is it ensured that any person starting hazardous movements intentionally can only do so with a direct view of the danger zone?	<input type="checkbox"/>		
3	Are all parameters parameterized for the inputs?	<input type="checkbox"/>		
4	Are unused inputs parameterized as "not used"?	<input type="checkbox"/>		
No	Requirement (optional)	Yes	No	Remark
5	Are safety distances that must be observed calculated according to the response and delay times implemented?	<input type="checkbox"/>	<input type="checkbox"/>	
		Date		Signature (test engineer 1)
		Date		Signature (test engineer 2)

## C 4 Validation

Checklist for validating the safety module			
<b>Device type/equipment identification</b>			
<b>Version: HW/FW</b>		<b>Date</b>	
<b>Test engineer 1</b>		<b>Test engineer 2</b>	
<b>Remark</b>			
No	Requirement (mandatory)	Yes	Remark
1	Have all the mandatory requirements for the "Planning" checklist been met?	<input type="checkbox"/>	
2	Have all the mandatory requirements for the "Assembly and electrical installation" checklist been met?	<input type="checkbox"/>	
3	Have all the mandatory requirements for the "Startup and parameterization" checklist been met?	<input type="checkbox"/>	
4	Does the parameterization of the safe inputs correspond to the version and the actual connection of the controlling device?	<input type="checkbox"/>	
5	Has the assignment of the sensors to the inputs and the variables of the safe application program been tested (also as online status in SAFETY-PROG)?	<input type="checkbox"/>	
6	Has a function test been performed to check all safety functions, in which the module is involved?	<input type="checkbox"/>	
7	Have measures been taken to achieve a specific Cat.?	<input type="checkbox"/>	
8	Do all cables correspond to the specifications?	<input type="checkbox"/>	
9	Does the voltage supply correspond to the specifications for the protective extra-low voltage in accordance with PELV?	<input type="checkbox"/>	
10	Is external fuse protection of the module implemented (according to the specifications in this user manual for supply voltage UM)?	<input type="checkbox"/>	
11	Have measures been taken to prevent simple manipulation?	<input type="checkbox"/>	
12	Have measures been taken to prevent plugs being mixed up?	<input type="checkbox"/>	
13	Are the requirements for the sensors and cable installation observed according to the SIL/SIL CL/Cat./PL to be achieved?	<input type="checkbox"/>	
14	Are the specifications for the parameterization for each channel implemented?	<input type="checkbox"/>	
15	For PROFIsafe: is the F_iPar_CRC parameter greater than 0 for all devices?	<input type="checkbox"/>	
16	Has it been ensured that any person intentionally starting hazardous movements has a direct view of the danger zone?	<input type="checkbox"/>	
		Date	Signature (test engineer 1)
		Date	Signature (test engineer 2)

## D Appendix: revision history

Revision	Date	Contents
01	27/02/2013	First publication