

| O.P. (MM)  | P.T. (MM) |
|------------|-----------|
| 15.5 ± 0.8 | 4.1 MAX.  |

O.P. = OPERATING POINT  
P.T. = PRE-TRAVEL

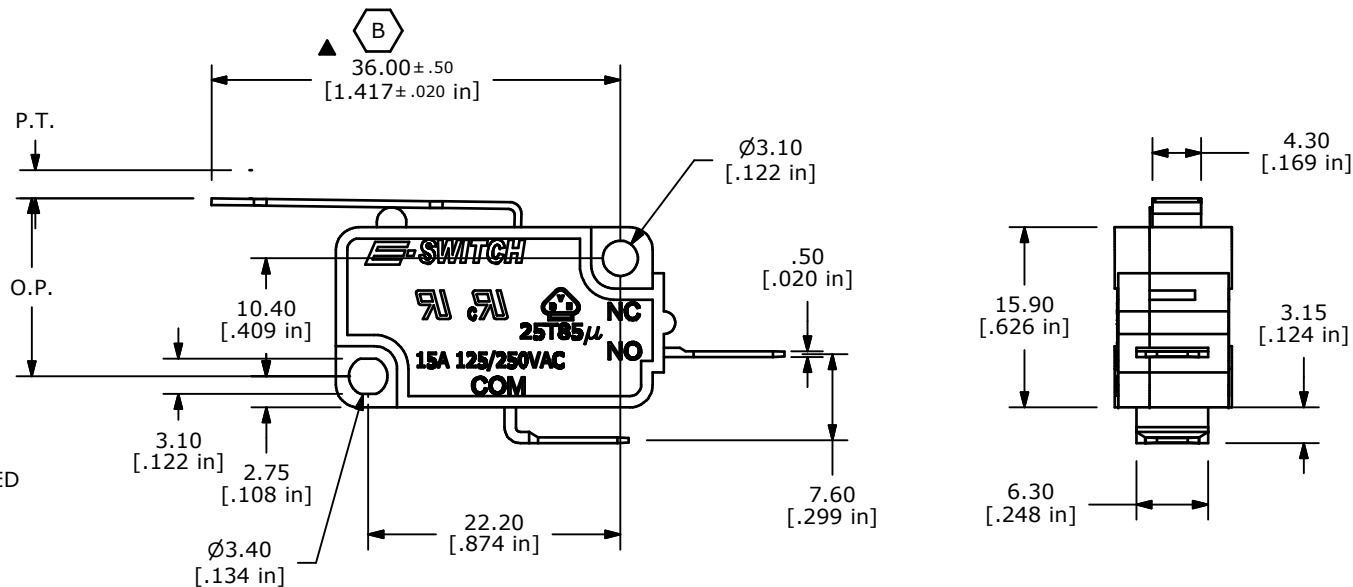

- NOTES:
1. ALL DIMENSIONS IN MM [INCH]
  2. GENERAL TOLERANCE: X.X ± 0.4  
X.XX ± 0.25
  3. RATING: 15A @125/250VAC UL, CUL, VDE APPROVED
  4. OPERATING FORCE: 120 ± 40 GRAMS
  5. OPERATING TEMP: -25°C TO 85°C
  6. ELECTRICAL LIFE: 50,000 CYCLES MIN.
  7. MECHANICAL LIFE: 1,000,000 CYCLES TYP.
  8. INSULATION RESISTANCE: 100 MEGA-OHMS MIN.
  9. DIELECTRIC STRENGTH: 1500VAC 1 MINUTE (INITIAL VALUE)
  10. CONTACT RESISTANCE: 100 MILLI -OHMS MAX.
  11. ▲ DENOTES CRITICAL PARAMETER.
  12. 2002/95/EC (ROHS) COMPLIANT

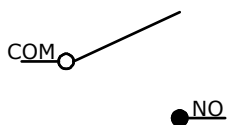

| REV | PCR NO | DESCRIPTION                    | DATE    | BY  |
|-----|--------|--------------------------------|---------|-----|
| B   | 20755  | 36.00 WAS 36.60, 4.70 WAS 4.75 | 9/17/12 | EBP |
| A   | 17535  | RELEASED FOR PRODUCTION        | 8/7/07  | BF  |

|                        |          |    |         |     |
|------------------------|----------|----|---------|-----|
| TITLE LS0851502F120C1C |          |    |         |     |
| SCALE                  | DATE     | DR | DWG     | REV |
| 1.5:1                  | 8/7/2007 | BF | Q950042 | B   |

THE INFORMATION CONTAINED IN THIS DOCUMENT IS PROPRIETARY TO E-SWITCH AND IS NOT TO BE COPIED OR TRANSFERRED