

PART NO.	ENG. NO.
02-06-2101	1560-(P901)
02-06-2103	1560-(P901)L
02-06-6101	1560-(561)
02-06-6102	1560-(561)L
02-06-6118	1560-(228)
02-06-6119	1560-(228)L
02-06-6116	1560-(231)
02-06-6112	1560-(231)L
02-06-6100	1560-(550)
02-06-6103	1560-(550)L
02-06-6105	1560-(591)
02-06-6104	1560-(591)L

**LEGEND**

1560-(\*\*\*\*)\*

P=PREPLATE  
BLANK=POSTPLATE

FORM  
BLANK=CHAIN  
L=LOOSE

FINISH CODE

- NOTES:
- MATERIAL: BRASS
  - FINISHES:
    - 901 HOT TIN DIP (.00051)/.000020 MIN.
    - \*228 SELECT GOLD PLATE (.00075)/.000030 MIN. IN CONTACT AREA, SELECT TIN (.00250)/.000100 MIN. IN CRIMP AREA OVER (.00125)/.000050 MIN. NICKEL OVERALL.
    - \*231 SELECT GOLD PLATE (.00125)/.000050 MIN. IN CONTACT AREA, SELECT TIN (.00250)/.000100 MIN. IN CRIMP AREA OVER (.00125)/.000050 MIN. NICKEL OVERALL.
    - 561 SELECT GOLD PLATE (.00076)/.000030 MIN. IN CONTACT AREA, OVER (.00127)/.000050 MIN. NICKEL OVERALL.
    - 591 SELECT GOLD PLATE (.00127)/.000050 MIN. IN CONTACT AREA, OVER (.00127)/.000050 MIN. NICKEL OVERALL WITH (.000025)/.000010 MAX. GOLD FLASH OVERALL.
    - 550 SELECT GOLD PLATE (.00038)/.000015 MIN. IN CONTACT AREA, OVER (.00076)/.000030 MIN. NICKEL OVERALL WITH (.000025)/.000010 MAX. GOLD FLASH OVERALL.
    - \* THE PRIMARY SHIPPING CARTON WILL BE LABELED, "COMPLIANT TO RoHS DIRECTIVE" 2002/95/EC AND ELV ANNEX II OF DIRECTIVE 2000/53/EC, AND CARTONS WITHOUT THIS LABEL MAY CONTAIN PRODUCT WITH TIN-LEAD.
  - PRODUCT SPECIFICATION: PS-02-06
  - PACKAGING INFORMATION: NOT AVAILABLE
  - TERMINAL FOR USE WITH (157)/.062 DIA. SERIES HOUSINGS AND WILL ACCEPT 18 THRU 24 AWG WIRE.

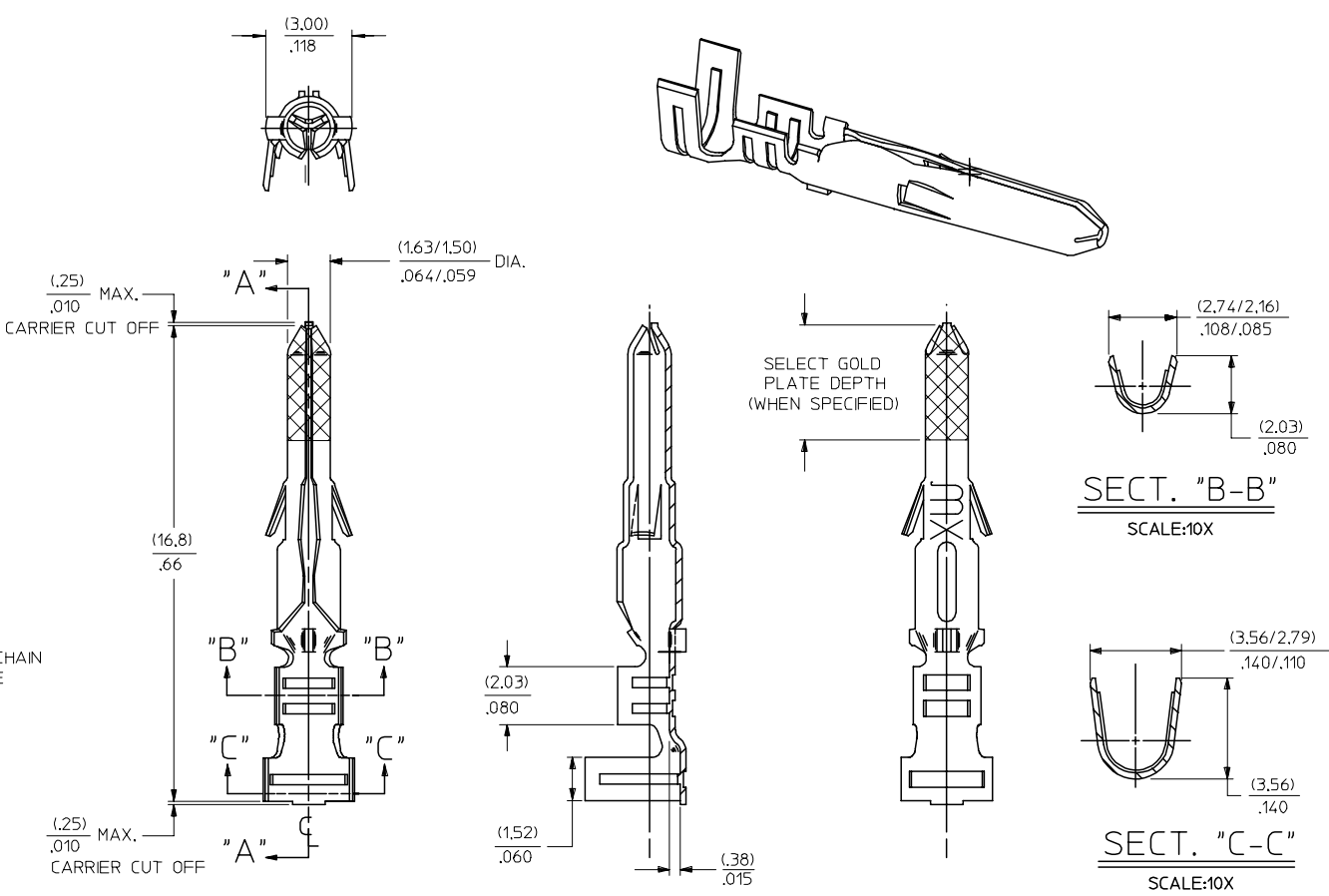

AP	REVSE Sn/Pb PLATE REDRAWN TO ME10 UCP2004-2097 RHOLTS 5/07/04
AO	REINSTATE 02066105 UCP2003-1827 ELHAG 03/02/24
AN	OBSOLETE P/N UCR2002-0270 COMERC 01/9/25
AM1	ADDED ISO VIEW UCR1998-0228 WANG 98-05-21
AM	REV. & REDRAWN PER ECR 10372 GEP 8-19-87 RW

REFER TO REVISION BLOCK EC NO: 2002/05/05 DRWNR:RHOLTS 2004/05/14 CHKD: 2004/05/14 APPR:FSMITH 2004/05/18	QUALITY SYMBOLS	GENERAL TOLERANCES (UNLESS SPECIFIED)	SCALE 8:1	DESIGN UNITS INCH	THIRD ANGLE PROJECTION	REVISE ON CAD ONLY
	DESCRIPTION	mm INCH	DIMENSION STYLE	TITLE	CRIMP TERMINAL, MALE .062 DIA. FOR 18-24 AWG WIRE	
AP	▽ = 0	4 PLACES ± --- ± ---	IN/MM	DRAWN BY GEP	DATE 1987/08/19	MOLEX MOLEX INCORPORATED
	▽ = 0	3 PLACES ± --- ± .010		CHECKED BY RW	DATE 1987/08/19	
		2 PLACES ± 0.25 ± .014		APPROVED BY RAS	DATE 1987/08/19	MATERIAL NO. SEE CHART
		1 PLACE ± 0.35 ± ---				DOCUMENT NO. SD-1560-*
		ANGULAR ±1/2°				SHEET NO. 1 OF 1
		DRAFT WHERE APPLICABLE MUST REMAIN WITHIN DIMENSIONS				