

.068 $\begin{matrix} +.003 \\ -.004 \end{matrix}$ X .038 DEEP KEYWAY

NOTE:
1. UNLESS OTHERWISE SPECIFIED ALL TOLERANCES TO BE ± 0.016 .

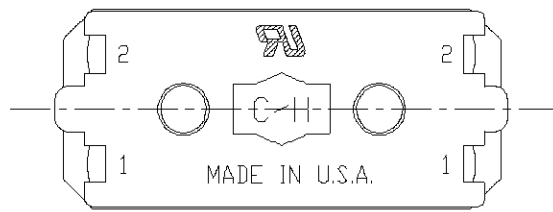
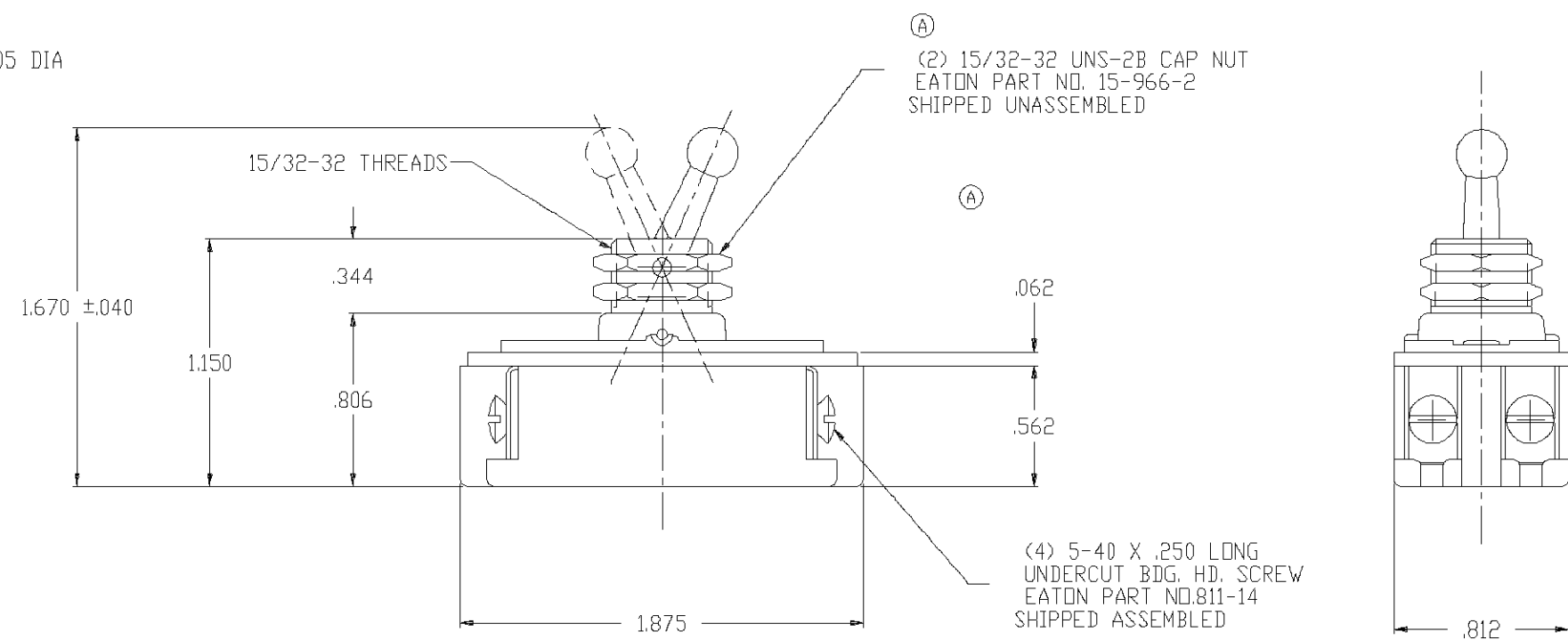
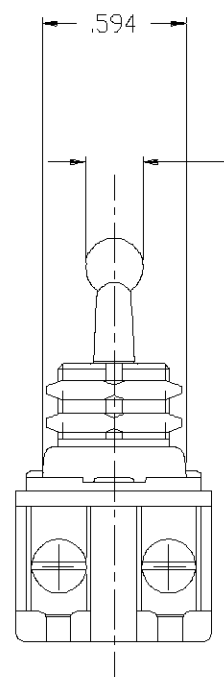

ORDER NO. 93719950

A	REMOVED 15-192 NUT NOTE, ADDED *(2)* TO 15-966-2 NUT NOTE.	6/29/94	D
B			E
C			F

THIRD ANGLE PROJECTION



TITLE: DOUBLE POLE 8A 250V/16A 125V ONE HOLE MTD. TOOL HANDLE TOGGLE SWITCH			
DR.	W. LEONARD	1/16/92	SURFACE COATING
CHK.	WESTEMEIER	1/22/92	SCALE
APP.	M.R. DUMMER	1/22/92	DO NOT SCALE DRAWING
		FIRST ASSEM. WHERE LISTED 7320K12	
		SUP'S	
		SUP'D BY	

B

91-284

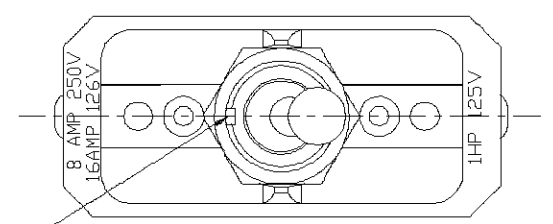

.068 $\begin{matrix} +.003 \\ -.004 \end{matrix}$ X .038 DEEP KEYWAY

NOTE:
1. UNLESS OTHERWISE SPECIFIED ALL TOLERANCES TO BE ± 0.016 .

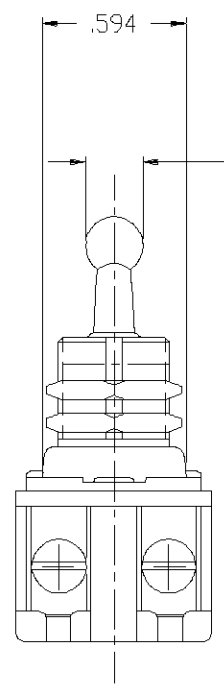

.240 ± 0.005 DIA

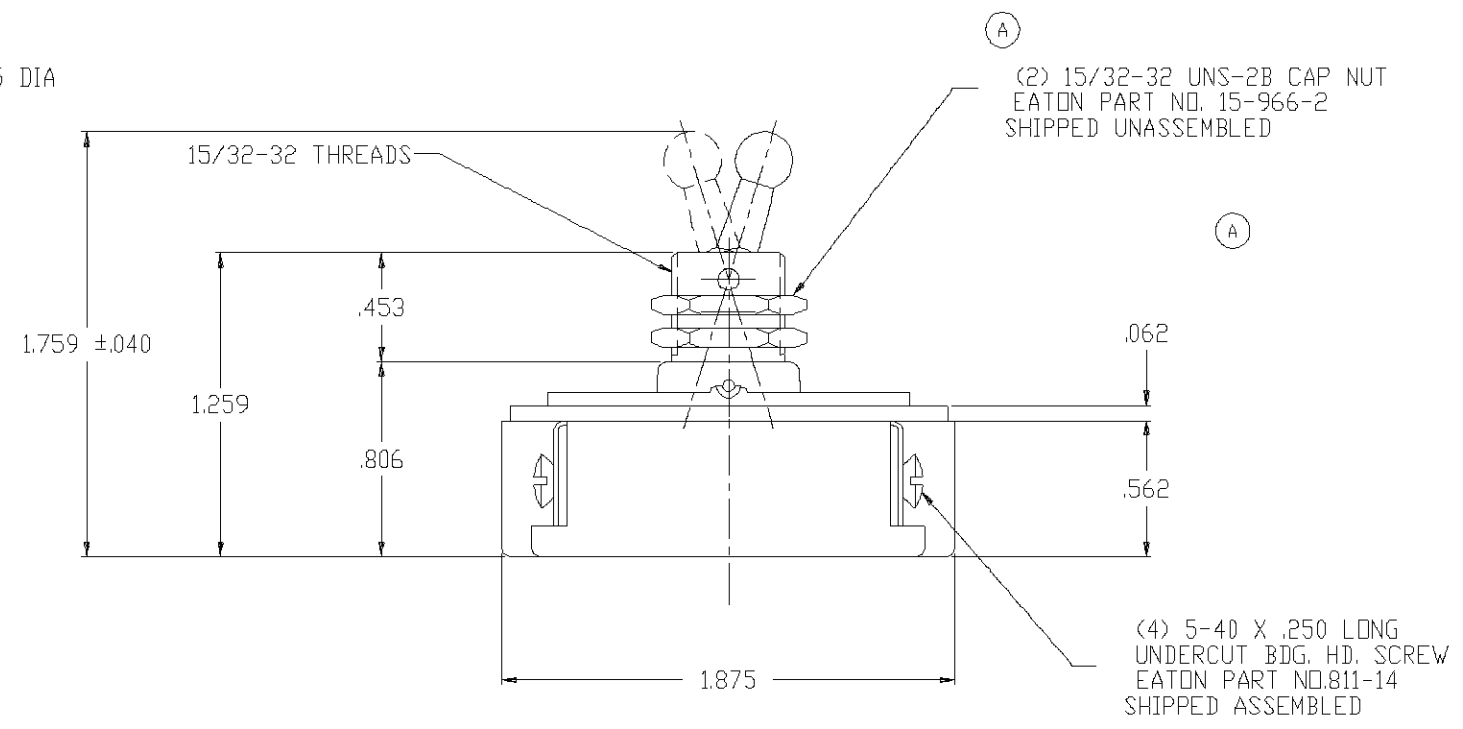

(A)
(2) 15/32-32 UNS-2B CAP NUT
EATON PART NO. 15-966-2
SHIPPED UNASSEMBLED

(A)
(4) 5-40 X .250 LONG
UNDERCUT BDG. HD. SCREW
EATON PART NO.811-14
SHIPPED ASSEMBLED

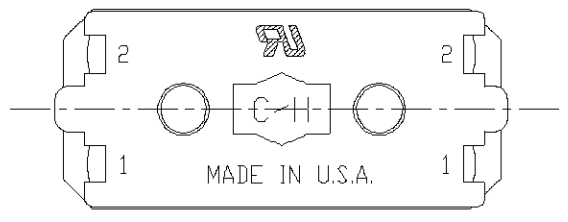
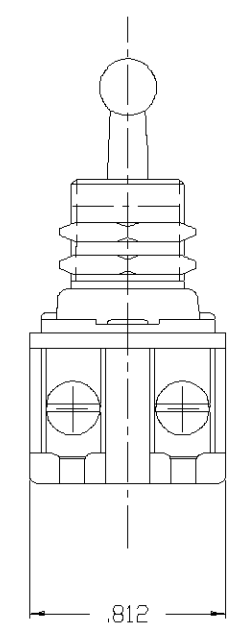

ORDER NO. 93719950

A	REMOVED 15-192 NUT NOTE, ADDED *(2)* TO 15-966-2 NUT NOTE.	6/29/94	D
B			E
C			F

THIRD ANGLE PROJECTION



TITLE: DOUBLE POLE 8A 250V/16A 125V ONE HOLE MTD. TOOL HANDLE TOGGLE SWITCH			
DR. W. LEONARD	1/16/92	SURFACE COATING	FIRST ASSEM. WHERE LISTED 7320K13
CHK. WESTEMEIER	1/22/92	SCALE	SUP'S
APP. M.R. DUMMER	1/22/92	DO NOT SCALE DRAWING	SUP'D BY