

THIS DRAWING IS UNPUBLISHED. RELEASED FOR PUBLICATION
 © COPYRIGHT BY TYCO ELECTRONICS CORPORATION. ALL RIGHTS RESERVED.

LOC		DIST		REVISIONS			
P	LTR	DESCRIPTION		DATE	DWN	APVD	
	E2	REVISED PER ECR-07-030483		21DEC07	HMR	KR	

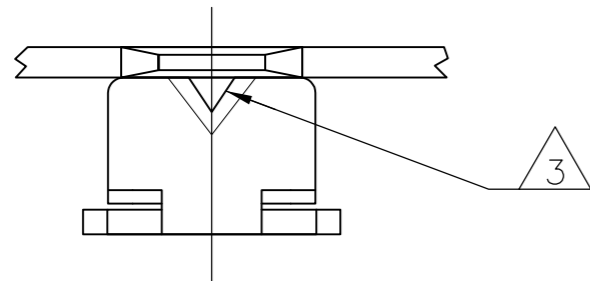

- 1 CONTINUOUS STRIP ON REELS WITH TERMINALS LOCATED ON 5.59±0.08 [.220±.003] CENTERS.
- 2 SLOT ACCEPTS 0.54-0.81mm [#23.5-#20] AWG COPPER MAGNET WIRE. 2 WIRES OF THE SAME AND TYPE PER SLOT. EXCEPT 0.64-0.81mm [#22-#20] AWG WHICH IS ONE WIRE ONLY.
- 3 POKE-IN ACCEPTS A 0.5-0.8mm² [#20-#18] AWG SOLID OR FUSED STRANDED LEAD WIRE.
- 4 0.002032 [.000080] MIN TIN PLATE
- 5 0.001270 [.000050] MIN NICKEL PLATE.
- 6 PRELIMINARY - NOT FOR PRODUCTION.

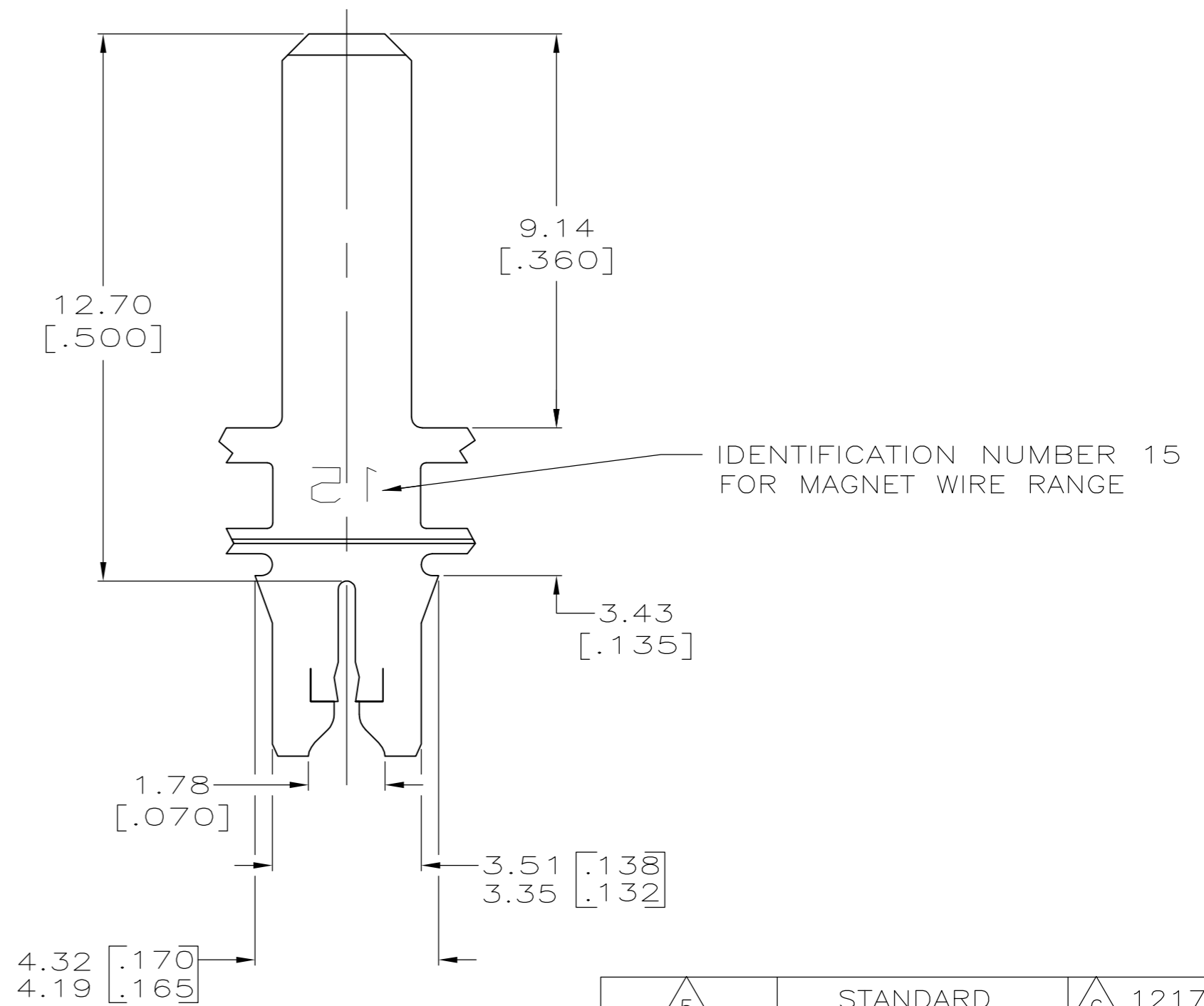
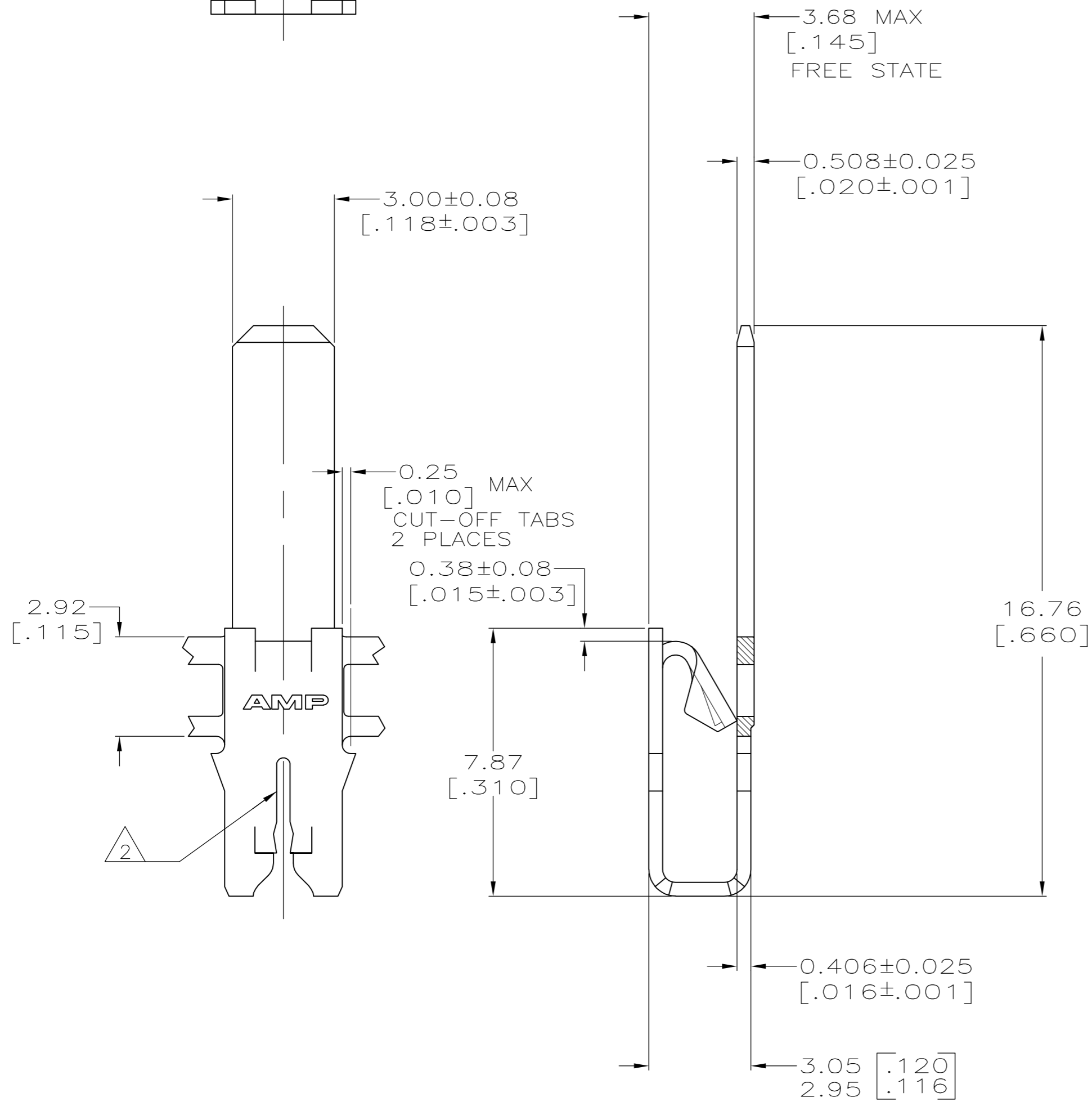

5	STANDARD	6	1217211-3
4	STANDARD		1217211-2
4	REVERSE		1217211-1
FINISH		REELING	
		PART NUMBER	

THIS DRAWING IS A CONTROLLED DOCUMENT.		DWN 14SEP1999 MICHAEL S. FEHER	Tyco Electronics Corporation Harrisburg, PA 17105-3608	
DIMENSIONS: mm [INCHES]		CHK 22SEP1999 KURT A. RANDOLPH	NAME TAB, POKE-IN/3.00 [.118] SERIES, COMBINATION, 300 SERIES MAG-MATE	
TOLERANCES UNLESS OTHERWISE SPECIFIED: 0 PLC ± - 1 PLC ± - 2 PLC ± 0.25 [.010] 3 PLC ± - 4 PLC ± - ANGLES ± -		APVD 22SEP1999 KURT A. RANDOLPH	PRODUCT SPEC 108-2012	
MATERIAL 4M PRE-MILLED BRASS		FINISH SEE TABLE	APPLICATION SPEC 114-2046	RESTRICTED TO -
		WEIGHT -	SIZE A2	CAGE CODE 00779
		CUSTOMER DRAWING	DRAWING NO C=1217211	SCALE 8:1
			SHEET 1 of 1	REV E2