

Si1143 Gesture Sensor (#28046)

The Si1143 Gesture Sensor uses infrared (IR) light to detect objects within its field of view. Using integrated detectors for IR and visible light, the device can measure levels of ambient IR and visible light as well as the amount of light reflected back from each of three onboard IR light emitting diodes (LEDs). A simple I²C communication interface allows easy integration with any microcontroller.

Light amplitude measurements can be processed by the application code to determine the approximate position of an object in front of the sensor and/or its relative distance from the sensor. To recognize "swipe" gestures, the application can monitor whether an object (for example, a user's hand) passes across the field of view in a particular direction or pattern.

As a human interface device, this sensor offers a unique method of control which is both intuitive and convenient; and because swipes are touchless the Si1143 Gesture Sensor can be used in applications where sanitation is important. Furthermore, the sensor may be used behind glass or in a windowed project enclosure to avoid contact with harsh environments or hazardous chemicals.

Device driver object code is provided for the Propeller microcontroller to make interfacing a breeze. And example applications are provided to demonstrate reading measurements and recognizing gestures.

Features

- Measures visible and IR ambient light levels
- Allows "touchless" object and swipe detection
- Configurable LED brightness and detector sensitivity
- Range of operation from darkness to full sunlight
- Compatible with any microcontroller
- Convenient design and standard 0.1" header pins

Key Specifications

- Power Requirements: Less than 4 mA average current with $V_{IN} = 3.0$ to 5.5 VDC
- Communication interface: I²C
- Operating temperature: -40 to 185 °F (-40 to 85 °C)
- Dimensions (including header): 2.00 x 2.28 x 0.22 in (5.08 x 5.79 x 0.51 cm)

Application Ideas

- Touchless remote to control music or video. Use swipe gestures for volume up/down, play/pause, and previous/next song, etc.
- Non-contact light switch controller
- Object detection for robotics and navigation
- Automatic faucet or equipment control for sanitary environments

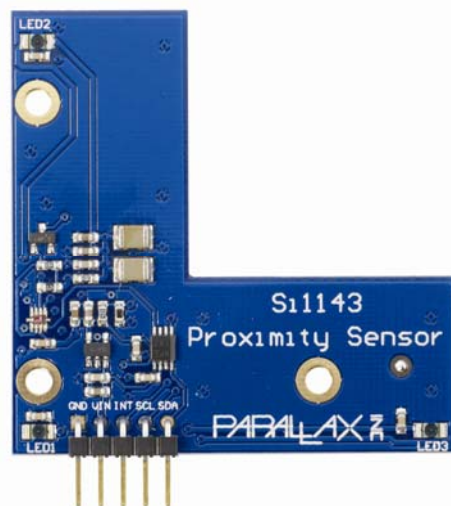

Quick-Start Guide

Follow this procedure to connect the device to a Propeller P8X32A or BASIC Stamp 2 microcontroller and run a demo program to test its operation. The program reads raw values from the device using I²C, and displays the values to a serial terminal.

Step 1

With power off, connect the circuit as shown.

For the Propeller P8X32A, Vdd is 3.3 VDC, and The microcontroller pins P0, P1, and P2 match the Propeller I/O pins used in the Spin example code.

For the BASIC Stamp 2, Vdd is 5 VDC, and R is 4.7 k Ω . The microcontroller pins P0 and P1 match BASIC Stamp I/O pins used in the PBASIC example code. Omit the P2 connection to the device's INT pin.

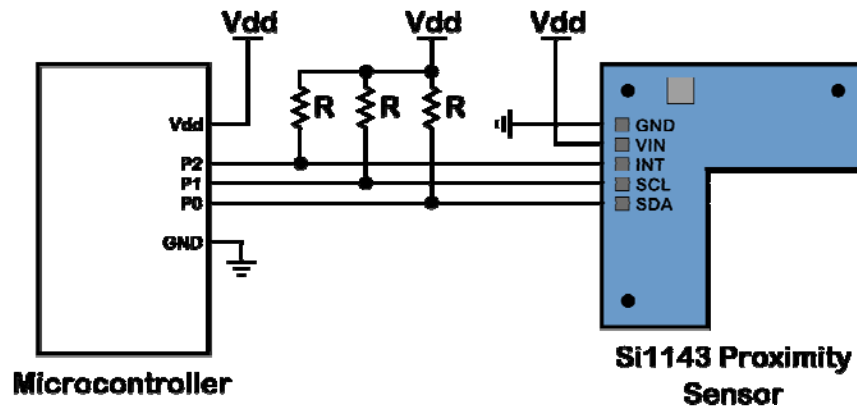

Step 2

Power on the circuit and load the demo code provided on the 28046 product page at www.parallax.com. For the Propeller P8X32A, use Si1143_Sensor_Demo.spin (the top object in the Spin code zip archive). Use 28046-Si1143_Sensor_Demo.bs2 for the BASIC Stamp 2.

Step 3

For the Propeller, after loading the Spin code into your microcontroller, run a serial terminal application such as Parallax Serial Terminal. The example code should continuously update the terminal display with the current measurement values.

For the BASIC Stamp, load the PBASIC code into the microcontroller; the BASIC Stamp Editor's Debug Terminal will open automatically.

Observe the serial terminal. See what happens to the measurement values when an object or hand is positioned in front of the sensor.

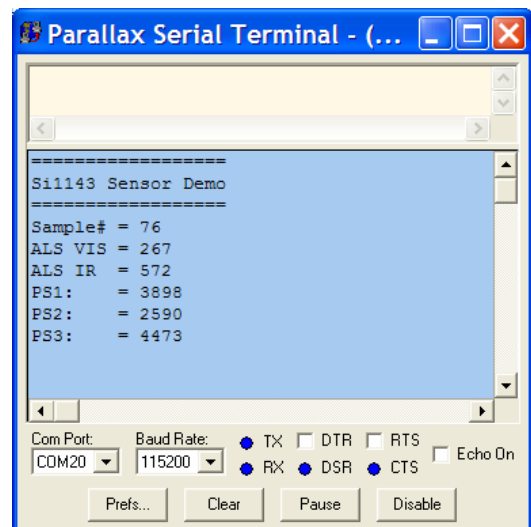

Theory of Operation

Measurement Sequence

The Si1143 device is equipped with photodiodes to capture visible and infrared (IR) light. By turning on each IR LED individually, the device can measure how much light is reflected from that single LED back to sensor. The internal analog-to-digital converters (ADCs) used to sample the photodiodes are designed to be fast and precise to capture a very rapid succession of light measurements during each measurement group. There are two main advantages in taking measurements in such quick bursts.

The first advantage is very low *average* power consumption by the circuit (as can be seen listed for Average Supply Current in the Recommended Operating section). If light levels can be measured quickly, then the IR LEDs may be pulsed on for a very short duration and the Si1143 device can spend most of its time with its main processor in a low-power standby state. Periodically it wakes up to perform measurement bursts which draw significant instantaneous current. However, with these brief high-current pulses spread out among long low-current standby states, the overall power drawn from the system can remain very low.

The second advantage of very fast measurement snapshots is good immunity to noisy ambient light sources. Most light sources have a certain amount of ripple. However, if light measurements can be taken over an extremely short time, the *instantaneous* ambient light level does not fluctuate significantly between each measurement.

For proximity measurements, the Si1143 device actually takes two measurements back to back. First, the IR light level is measured with the LED off, to detect the ambient level alone. Then the LED is turned on and the IR light level is measured again, to detect ambient light plus the light reflected/leaked from the LED. The idea is that ambient light level hasn't changed significantly in that short time (about 25.6 μ s), so the ambient measurement is subtracted within the Si1143 device to provide proximity measurements which are reasonably immune to ambient light conditions.

For more information relating to the measurement sequence see the "Functional Description" section in the Si114x datasheet and the "Proximity Measurements" section in application note AN498 found on the manufacturer's website: www.silabs.com.

Object Detection and Gesture Recognition

Objects can be detected by observing the level of reflected IR light measured in each proximity sensor (PS) measurement. With an open field of view, the PS measurement value will represent only optical leakage and cross-talk from the LED to the sensor. By reading the average "baseline" leakage, the PS values can be corrected in software to approximately zero-out the contribution of optical cross-talk.

Using three LEDs in an "L" shape on this board allows triangulation of the object within the field of view. For example, when a hand is placed more over one LED than the others, the sensor will measure more reflected light from that LED versus the other two. When a hand is positioned directly over all three LEDs the three PS measurements should be relatively equal.

Since the approximate position of the object can be detected, so can the motion of that object across the field of view. The main idea is to set a threshold value for when an object is considered "seen" or "not seen." The threshold allows rising and falling edges to be captured on each PS channel when an object enters the field of view. Analyzing the type of edge transitions and their order allows the application to determine that an object is entering or leaving the field of view and also determine the particular direction.

Communication Interface

The device uses I²C to communicate with an attached microcontroller. On-board level-shifting buffers allow the voltage rail for the SDA and SCL pins to match the VIN voltage. While I²C protocol is well-documented elsewhere, an overview relating to how registers are arranged and used in the Si1143 will hopefully provide a jumpstart in understanding and operating this device.

The Si1143 device has many values which require fast and frequent access. It provides direct access to these registers using standard I²C read/write operations. Additionally, these values may be read/written without waking up the main sequencer in the Si1143, allowing continued low-power operation. These are known as the **I²C registers**.

The Command and Response I²C registers provide a messaging interface to the sequencer in the Si1143, and also allow access to environmental parameters in the **Parameter RAM** space. Writing a value into the Command register causes the sequencer to wake up and service the request. The Response register is written into by the sequencer after each command is processed. If a Command was written while the sequencer was busy performing a measurement or other operation, it may not actually have been processed. Therefore, the Response register should be checked after writing every Command to ensure each command is processed successfully, or re-write to the Command register if it was not.

To read values in Parameter RAM, write the command/address into the Command register, read the Response register to ensure the command was processed, then read the requested Parameter value which was placed in the PARAM_RD (read) register. To write values to the Parameter RAM, write the value into the PARAM_WR (write) register, then write the command/address into the Command register. Read the Response register to ensure the command was processed, and optionally confirm that the correct value was placed into the PARAM_WR (write) register.

For more information, see the code implementation for the Si1143.spin object. Also refer to section 4, "Programming Guide", of the Si114x datasheet and application note AN498 from the manufacturer's website at: www.silabs.com.

Module Pins and Dimensions

Pin	Name	Type	Function
1	GND	Power	Ground
2	VIN	Power	Supply voltage
3	INT	Output	Sample ready interrupt pin
4	SCL	Input	I ² C clock
5	SDA	Input/Output	I ² C data

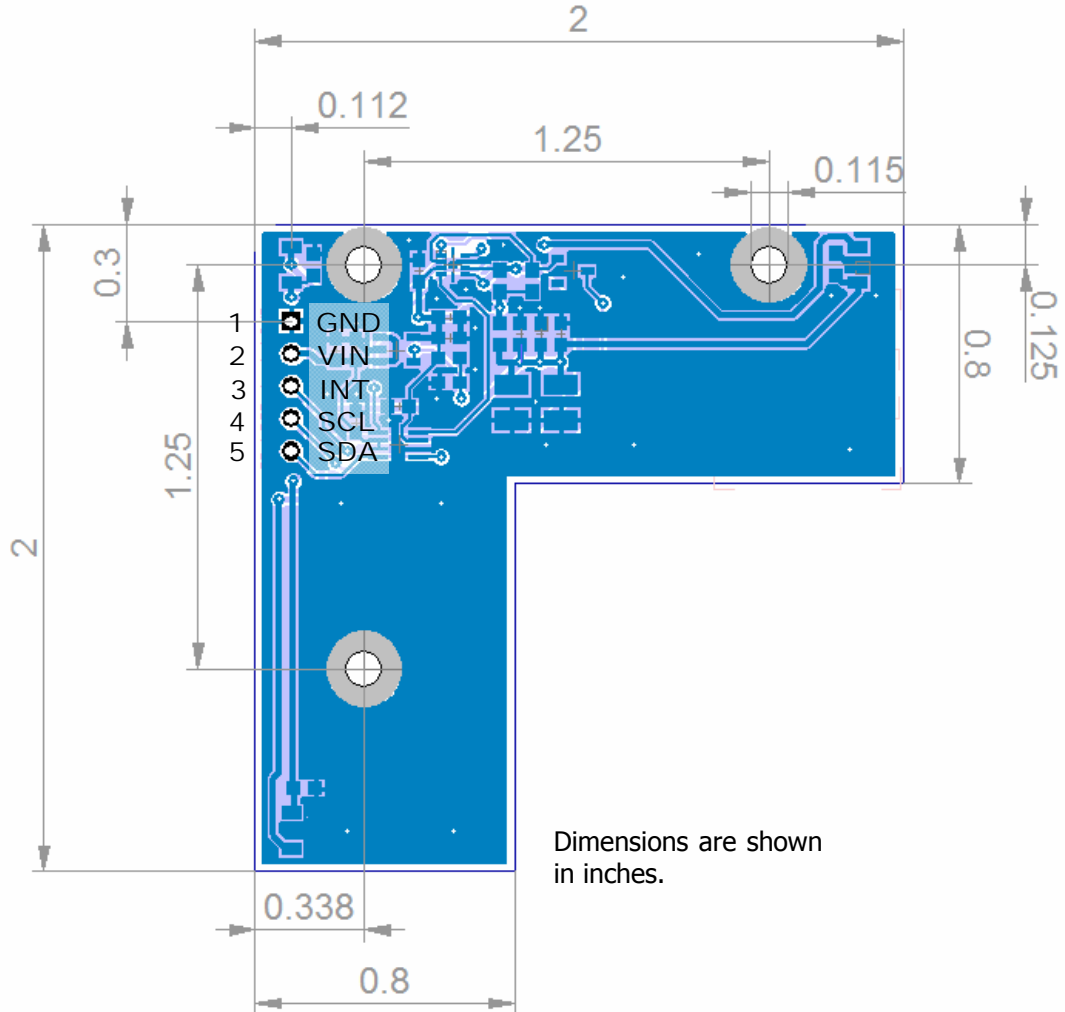

Absolute Maximum Ratings

Parameter	Min	Max	Units
Supply Voltage on VIN Pin	-0.5	6.0	V
Voltage on SDA or INT Pin	-0.5	6.5	V
Voltage on SCL Pin	-0.5	30	V
Storage Temperature	-67 -55	+185 +85	°F °C
Operating Temperature	-40 -40	+185 +85	°F °C

Stresses beyond these ratings may cause permanent damage to the device. Exposure to absolute-maximum-rated conditions for extended periods may affect device reliability. Refer to "Recommended Operating Conditions" section for ratings to use during normal operation.

Recommended Operating Conditions

Unless otherwise noted, VIN = 3.3V, TA = 25°C.

Parameter	Symbol	Conditions	Min	Typ	Max	Units
Supply Voltage	V _{IN}		3.0		5.5	V
I/O Pin Voltage	V _{I/O}		0		V _{IN}	V
Average Supply Current ⁽¹⁾	I _{IN}	Idle (0 meas/sec)		0.096		mA
		180mA LED Drive Current: Meas. Rate = 1 meas/sec Meas. Rate = 50 meas/sec Meas. Rate = 100 meas/sec		1.383 1.465 1.810		
LED1, LED2, LED3 Programmable LED Drive Current.	I _{LED}	360mA LED Drive Current: Meas. Rate = 1 meas/sec Meas. Rate = 50 meas/sec Meas. Rate = 100 meas/sec		1.461 2.678 3.293		mA
		PS_LEDn = 0001 PS_LEDn = 0010 PS_LEDn = 0011 PS_LEDn = 0100 PS_LEDn = 0101 PS_LEDn = 0110 PS_LEDn = 0111 PS_LEDn = 1000 PS_LEDn = 1001 PS_LEDn = 1010 PS_LEDn = 1011 PS_LEDn = 1100 PS_LEDn = 1101 PS_LEDn = 1110 PS_LEDn = 1111		5.6 11.2 22.4 45 67 90 112 135 157 180 202 224 269 314 359		
LED1, LED2, LED3 Pulse Width	t _{PS}			25.6	30	µs
Measuring Time	t _{meas}	Two ALS plus three PS measurements.		660		µs
Startup Time	t _{INIT}		25			ms
Sampling Rate ⁽²⁾	f _{SAMPLE}	Two ALS plus three PS measurements at 360 mA setting.			100	s/sec
I2C Clock Frequency	f _{SCL}				3.4	MHz

1. Measurements are taken with no I²C activity.

2. Maximum sampling rate is limited by the circuit supplying power to the LEDs (in order to allow a wide operating voltage range).

The Si1143 device may be operated at higher sampling rates; however, voltage sag in the LED supply net may result in distorted measurements since the LED drive current may not be consistent through the measurement sequence.

Propeller™ P8X32A Example Code

The "Si1143_Sensor_Demo.spin" application reads raw values from the device using I²C, and displays the values to the serial terminal.

The "Si1143_Gesture_Demo.spin" application filters and interprets gestures and outputs a tone jingle for each recognized gesture. The program also displays the gesture events to the serial terminal.

The zip archives for these Spin applications available on the 28046 product page. Code can be downloaded to the Propeller microcontroller using the Propeller Tool software, which is available from www.parallax.com/Propeller.

BASIC Stamp® Example Code

The "28046-Si1143_Sensor_Demo.bs2" program is available on the 28046 product page. The demo reads raw values from the device using I²C, and displays the values to the BASIC Stamp Editor's Debug Terminal. The Basic Stamp software is a free download from www.parallax.com/basicstampsoftware.

Resources and Downloads

Additional resources, example code, device datasheet, schematic, and circuit board layout files are available on the Si1143 Gesture Sensor product page. Go to **www.parallax.com** and search for part number **28046**. For complete details on the Si1143 device, refer to the manufacturer's datasheet.

Revision History

Version 1.0

Initial document release.

Version 1.1

Corrected dimensions, minor formatting updates.

Version 1.2

Product name change from Si1143 Proximity Sensor to Si1143 Gesture Sensor.