

Classification	REFERENCE SPECIFICATION	Issue No. 20151588
Part Name 3.5mm x 2.9mm Side-Operational SMD Light Touch Switch	Part No. EVQ9P701P	1 / 8
<p>1. Notification Items</p> <p>1.1 Law and the regulation which are applied</p> <p>Ozone depleting substances specified by Montreal Protocol have not been used in the manufacturing process of the material used in this product.</p> <p>This product complies with RoHS Directive (on the restriction of the use of certain hazardous substances in electrical and electronic equipment) (2011/65/EU).</p> <p>The materials used in this product contain only the substances listed in the List of Existing Chemical Substances specified in 'Act on the Evaluation of Chemical Substances and Regulation of Their Manufacture, etc'.</p> <p>Permission must be obtained from the Japanese government if the product that is subject to the "Foreign Exchange and Foreign Trade Law" is to be exported or taken out of Japan.</p> <p>1.2 Application Limits</p> <p>The following shall be described for safety precaution:</p> <p>[Limitation of Application]</p> <ul style="list-style-type: none"> - This product has been designed and manufactured for general electronic devices, such as home electronics, office equipment, information device and communication devices. In an event that this product is used for more sophisticated applications requiring higher safety and reliability and its failure or malfunction of this product may impose damage to human life or property, agreement on product specifications for approval suitable for such applications are required. Such applications shall include the following: <ul style="list-style-type: none"> aircraft equipment, aerospace equipment, disaster prevention / crime prevention equipment, medical equipment, transportation equipment (vehicles, trains, ships, etc.), information processing equipment that are highly publicized, and other equivalent equipment - Regardless of its applications, in an event that this product is used for the equipment requiring high safety levels, place protective circuits or redundant circuits and perform safety tests to improve your products safety. <p>1.3 Handling of reference specification.</p> <ul style="list-style-type: none"> · Since the contents of this reference specification are subjected to change without prior notifications, please request us a formal specification again for your investigations before using. <p>1.4 Manufacturing Sites</p> <p>The country of manufacture : Malaysia Panasonic Industrial Devices Malaysia Sdn. Bhd. The country of manufacture : China Panasonic Industrial Devices (Qingdao) Co., Ltd.</p> <p>2. Summary</p> <p>2.1 This specifications applies to the following types of switch. Push-ON type S.P.S.T</p> <p>2.2 This specifications is a constituent document of contract for business concluded between your company and Panasonic Corporation.</p> <p>2.3 Items not particularly specified in this specifications shall be in conformance with JIS Standards.</p>		

Classification	REFERENCE SPECIFICATION	Issue No. 20151588
Part Name 3.5mm x 2.9mm Side-Operational SMD Light Touch Switch	Part No. EVQ9P701P	2 / 8

3. Dimension · Marking · Circuit diagram

REFERENCE ONLY

Date code are indicated in the product.
 General dimension tolerance : ± 0.2
 () dimensions are reference dimensions.

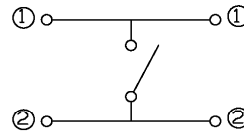
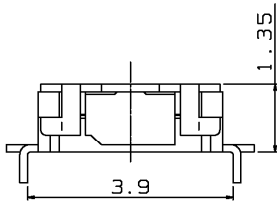
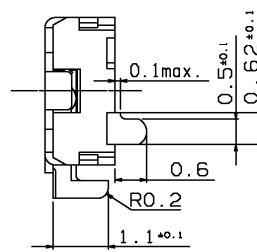
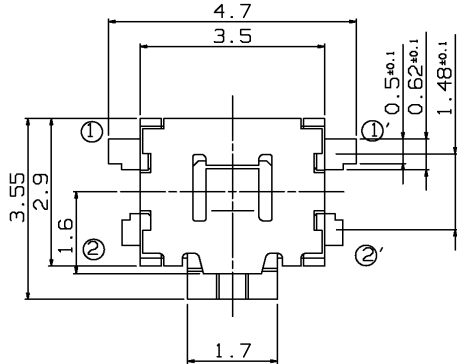

Circuit Diagram
 Please connect ② and ②' to the Ground terminal for ESD.

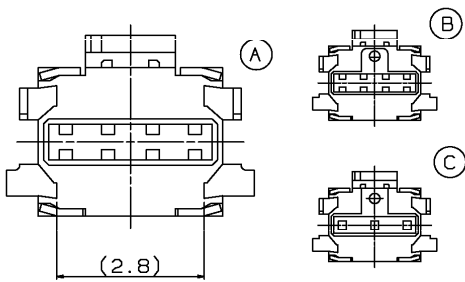

Either (A) or (B) or (C) type will be used because of variety of molding dies.

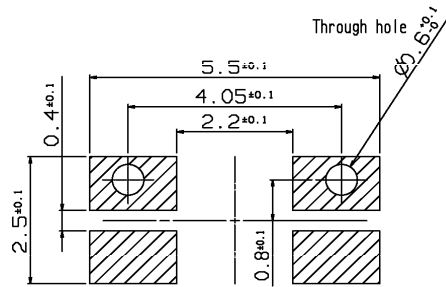

Land pattern plan

Knob color : BLACK

Piece weight : about 0.035g

Solder thickness t=0.12 ± 0.02

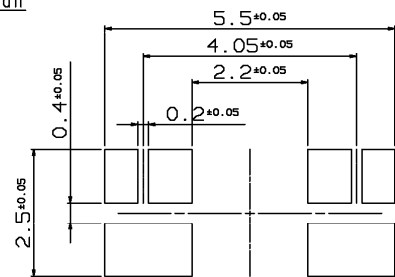
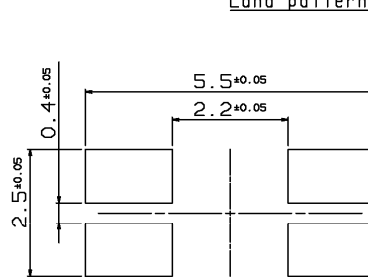

Solder mask A

Solder mask B

In case too much solder paste is applied, B mask would be good to resolve the phenomenon.

Classification	REFERENCE SPECIFICATION	Issue No. 20151588
Part Name 3.5mm x 2.9mm Side-Operational SMD Light Touch Switch	Part No. EVQ9P701P	3 / 8

4. General specification

4.1 Switch rating DC 12 V 50 mA(max.) DC 2 V 10 μA(min.)

4.2 Operation temperature range -20 ~ + 70

4.3 Preservative temperature range Single condition : - 40 ~ + 85
Taping conditior : - 20 ~ + 60

4.4 Standard conditions

Unless otherwise specified, the test and measurements shall be carried out as follows.

- Ambient temperature : 5 ~ 35
- Relative humidity : 45 ~ 85 %
- Atmospheric pressure : 86 ~ 106 kPa

However, if doubt arises on the decision based on the measured values under the above-mentioned conditions, the following conditions shall be employed.

- Ambient temperature : 20 ± 2
- Relative humidity : 65 ± 5 %
- Atmospheric pressure : 86 ~ 106 kPa

5. Performance

5.1 Electrical characteristics

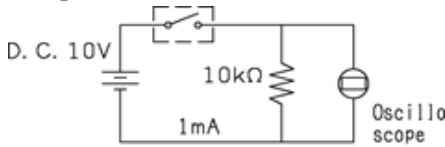
No.	ITEM	TEST CONDITION	PERFORMANCE
5.1.1	Contact resistance	Push force : {Operation force} × 2 Measurement tool : Contact resistance meter (Capable of 10 μA ~ 10 mA)	500 mΩ max.
5.1.2	Insulation resistance	DC 100 V (Between terminals)	100 MΩ min.
5.1.3	Withstand voltage	AC 250 V for 1 minute. (Between terminals)	No insulation destruction
5.1.4	Bouncing	Operation speed : 3 ~ 4 times/s 	ON 10 ms max. OFF 10 ms max.

5.2 Mechanical characteristics

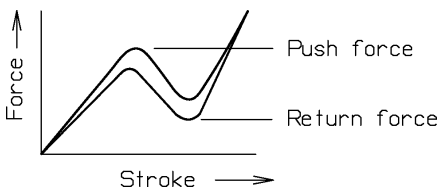
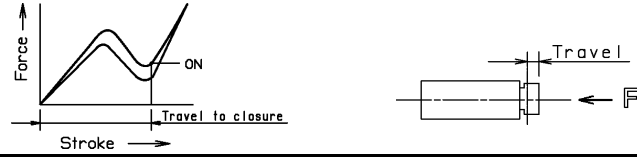
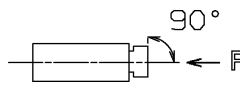
No.	ITEM	TEST CONDITION	PERFORMANCE
5.2.1	Operation force		Push force $1.6 \begin{matrix} + \\ - \end{matrix} \begin{matrix} 0.7 \\ 0.4 \end{matrix} \text{ N}$ Return force 0.1 N min
5.2.2	Travel to closure		$0.2 \begin{matrix} + \\ - \end{matrix} \begin{matrix} 0.2 \\ 0.1 \end{matrix} \text{ mm}$
5.2.3	Push strength	30 N for 1 minute. 	No damage (Electrical and mechanical)
5.2.4	Vibration test	1) Amplitude : 1.5 mm 2) Sweep rate : 10-55-10Hz for 1 minute 3) Sweep method : Logarithmic frequency sweep rate 4) Vibration direction : X,Y,Z(3 directions) 5) Time : Each direction 2 hours (Total 6 hours)	No.5.1 and 5.2.1 to 5.2.2 shall be satisfied.
5.2.5	Soldering heat test	Mount the switch on P.W.B by solder paste. 1) Reflow process 2 times. (Refer to section 6.1) 2) Standard conditions after test : 1 hours	Contact resistance 500 mΩ max. No.5.1.2 to 5.1.4 and No.5.2.1 to 5.2.2 shall be satisfied.
5.2.6	Solderability	After spreading flux, the terminal is immersed in solder with following condition. Solder bar : M705/Sn-3.0Ag-0.5Cu (Senju Metal Industry Co.,Ltd.) Flux : CF-110VH-2A (tamura kaken) Soldering temperture : 260±5 Soldering time : 2±0.5 sec.	95% or more of surface area(Excluding ruptured surface)where is immersed in solder shall be covered by new solder.

Classification	REFERENCE SPECIFICATION	Issue No. 20151588
Part Name 3.5mm x 2.9mm Side-Operational SMD Light Touch Switch	Part No. EVQ9P701P	5 / 8

5.3 Climatic characteristics

No.	ITEM	TEST CONDITION	PERFORMANCE
5.3.1	Cold test	1) Temperature : -40 ± 2 2) Duration of test : 500h 3) Take off a drop water. 4) Standard conditions after test : 1 h	Contact resistance 500 mΩ max. No.5.1.2 to 5.1.4 and No.5.2.1 to 5.2.2 shall be satisfied.
5.3.2	Heat test	1) Temperature : 85 ± 2 2) Duration of test : 500h 3) Standard conditions after test : 1 h	Contact resistance 500 mΩ max. No.5.1.2 to 5.1.4 and No.5.2.1 to 5.2.2 shall be satisfied.
5.3.3	Heat shock test	1) Test cycles : 20 cycles 2) Standard conditions after test : 1 h <div style="text-align: center;"> </div> A: $+85\pm 2$ B: -40 ± 2 C: 1 hour D: 5 minutes max. E: 1 hour F: 5 minutes max.	Contact resistance 500 mΩ max. No.5.1.2 to 5.1.4 and No.5.2.1 to 5.2.2 shall be satisfied.
5.3.4	Humidity test	1) Temperature : 60 ± 2 2) Relative humidity : 90 ~ 95 % 3) Duration of test : 500 h 4) Take off a drop water. 5) Standard conditions after test : 1 h	Contact resistance 500 mΩ max. No.5.1.2 to 5.1.4 and No.5.2.1 to 5.2.2 shall be satisfied.
5.3.5	Endurance (Switching action)	1) DC 12 V 50 mA Resistance load 2) Operation speed : 2 ~ 3 times/s 3) Push force : Maximum value of operation force 4) Operation number : 100,000 times	Contact resistance 1000m Ω max. Bouncing : 20 ms max. Variation rate of operation force shall be within $\pm 30\%$ to the value before testing No.5.1.2 and 5.2.2 shall be satisfied.
5.3.6	Withstand H ₂ S	1) Density : 3 ± 1 ppm 2) Temperature : 40 ± 2 3) Relative humidity : 80 ~ 85 % 4) Duration of test : 24 h 5) Standard conditions after test : 1 h	Contact resistance 500 mΩ max. No.5.1.2 to 5.1.4 and No.5.2.1 to 5.2.2 shall be satisfied.

Classification	REFERENCE SPECIFICATION	Issue No. 20151588
Part Name 3.5mm x 2.9mm Side-Operational SMD Light Touch Switch	Part No. EVQ9P701P	6 / 8

6. Prohibitions and precaution for handling

6.1 Reflow soldering condition

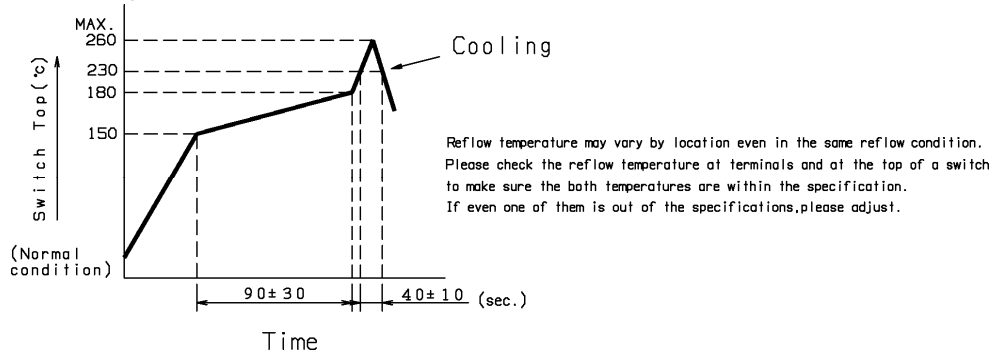

- 1) Two times max. with directing the switch mounting side of P.W.B up.
- 2) Re-soldering by soldering iron shall be allowed under 350 max. 3 sec. max. 1 time only and the tip of iron must not touch to terminals.
Soldering iron for re-soldering have to be 60 W max.

6.2 Design instructions

- 1) Please refer to the land pattern plan Panasonic recommends on the 2nd page.
- 2) Design key top as fig-1. Design inclination of key top 5 deg. max. as fig-2 and fig-3.
In order to protect the switch from direct impact, install the stopper as fig-4.
Deviation between center of key top and switch should be within 0.3 mm. as fig-5.

(Recommended operation condition)

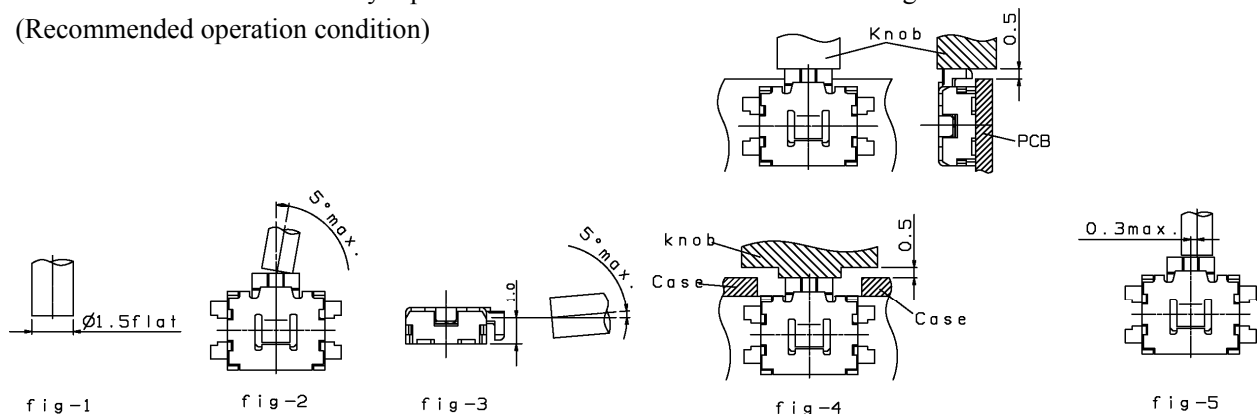

6.3 Note

- 1) Please use caution not to give excessive static load or shock.
Do not apply load to the switch except to the operation part in the operation direction.
- 2) In case of this switch to be mounted to the edge of P.W.B., please avoid flow soldering on any other parts after this switch is mounted as flux may enter into the switch.
- 3) Storage under high temperature, high humidity, or corrosive gas should be avoided.
When a long period of storage is required, please keep the carton unopened.
- 4) Please avoid any usage under the condition that switch to be continuously pressed to ON position for a long time.
- 5) Please do not wash or clean the switch with water or an organic solvent.
- 6) If a large amount of solder paste is applied around the switch, flux from solder paste may enter into the switch. Especially this switch requires through holes on the land pattern, and solder paste tends to be used too much. Therefore please embrace our recommend land pattern and solder mask specified in this specification. Please also avoid any additional land patterns around the switch on P.W.B. If flux entering into the switch occurs, please use solder mask B in page 2 in order to adjust the volume of solder paste.

Classification	REFERENCE SPECIFICATION	Issue No. 20151588
Part Name 3.5mm x 2.9mm Side-Operational SMD Light Touch Switch	Part No. EVQ9P701P	7 / 8

7. Packing specification
Carrier tape

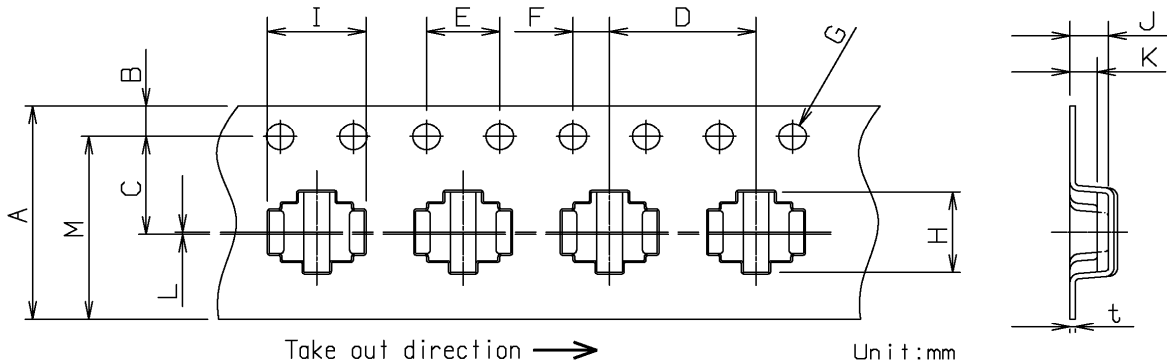

A	B	C	D	E	F	G	H	I	J	t	K	L	M
±0.3	±0.1	±0.1	±0.1	±0.1	±0.1	$\begin{matrix} +0.1 \\ -0.1 \end{matrix}$	±0.2	±0.2	±0.2	±0.1	±0.2	±0.1	(10.25)
12	1.75	5.5	8	4	2	1.5	4.5	5.2	2.1	0.3	1.5	0.12	

Taping condition : Lack of products in the middle of taping should be one MAX, but total quantity specified in the specifications should be secured.

Peeling off strength of top tape : It should be within 0.2N to 1.0N at 165 degree in peeling off angle.

Joint of carrier tape : One joint per one reel may exist.

Reel (5000pcs./reel)

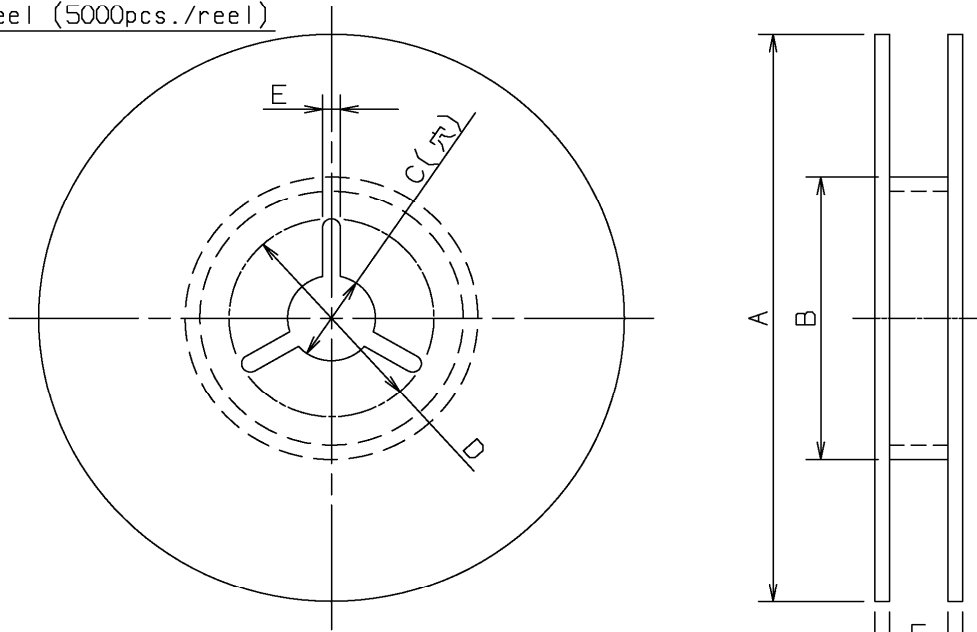

A	B	C	D	E	F	G
±2	±1	±0.5	±1	±0.5	±1	±1
∅380	∅80	∅13	∅21	2	13.5	17.5

Classification	REFERENCE SPECIFICATION	Issue No. 20151588
Part Name 3.5mm x 2.9mm Side-Operational SMD Light Touch Switch	Part No. EVQ9P701P	8 / 8
<p><Prohibitions and precaution for handling></p> <p>[Prohibited items on fire and smoking]</p> <ul style="list-style-type: none"> · Absolutely avoid use of a product beyond its rated range because doing so may cause a fire. If misuse or abnormal use may result under conditions in which the product is used out of its rated range, take proper measures such as current interruption using a protective circuit. · The grade of nonflammability for resin used in product is "94HB, " which is based on UL94 Standards (flammability test for plastic materials). Prohibit use in a location where a spreading fire may be generated or prepare against a spreading fire. <p>[For use in equipment for which safety is requested]</p> <ul style="list-style-type: none"> · Although care is taken to ensure product quality, inferior characteristics, short circuits, and open circuits are some problems that might be generated. To design an equipment which places maximum emphasis on safety, review the effect of any single fault of a product in advance and perform virtually fail-safe design to ensure maximum safety by: <ul style="list-style-type: none"> · Preparing a protective circuit or a protective device to improve system safety, and equipment. · Preparing a redundant circuit to improve system safety so that the single fault of a product does not cause a dangerous situation. <p>[Attentions required for storage condition]</p> <ul style="list-style-type: none"> · When this product is to be stored in the following circumstances and conditions, it may affect on the performance deteriorations and solderability etc., avoid storing in the following conditions. <ol style="list-style-type: none"> (1) A place where the temperature is -10 max., +40 min. and the humidity is 85% min. (2) In the corrosive gas atmosphere. (3) Long-term storage for 6 months min. (4) A place where the product is exposed to direct sunlight. · Store in packed condition so that the load stress is not applied. · Please use this product as soon as possible, our recommendation is within 3 months and the limitation is 6 months. · If any remainder left after packing is opened, store it with proper moistureproofing and gasproofing, etc., 		