

PART NUMBER	REV	FIRST USED
680098-1	B	854400-1
680098-2	B	565435-5
680098-3	B	354500-1

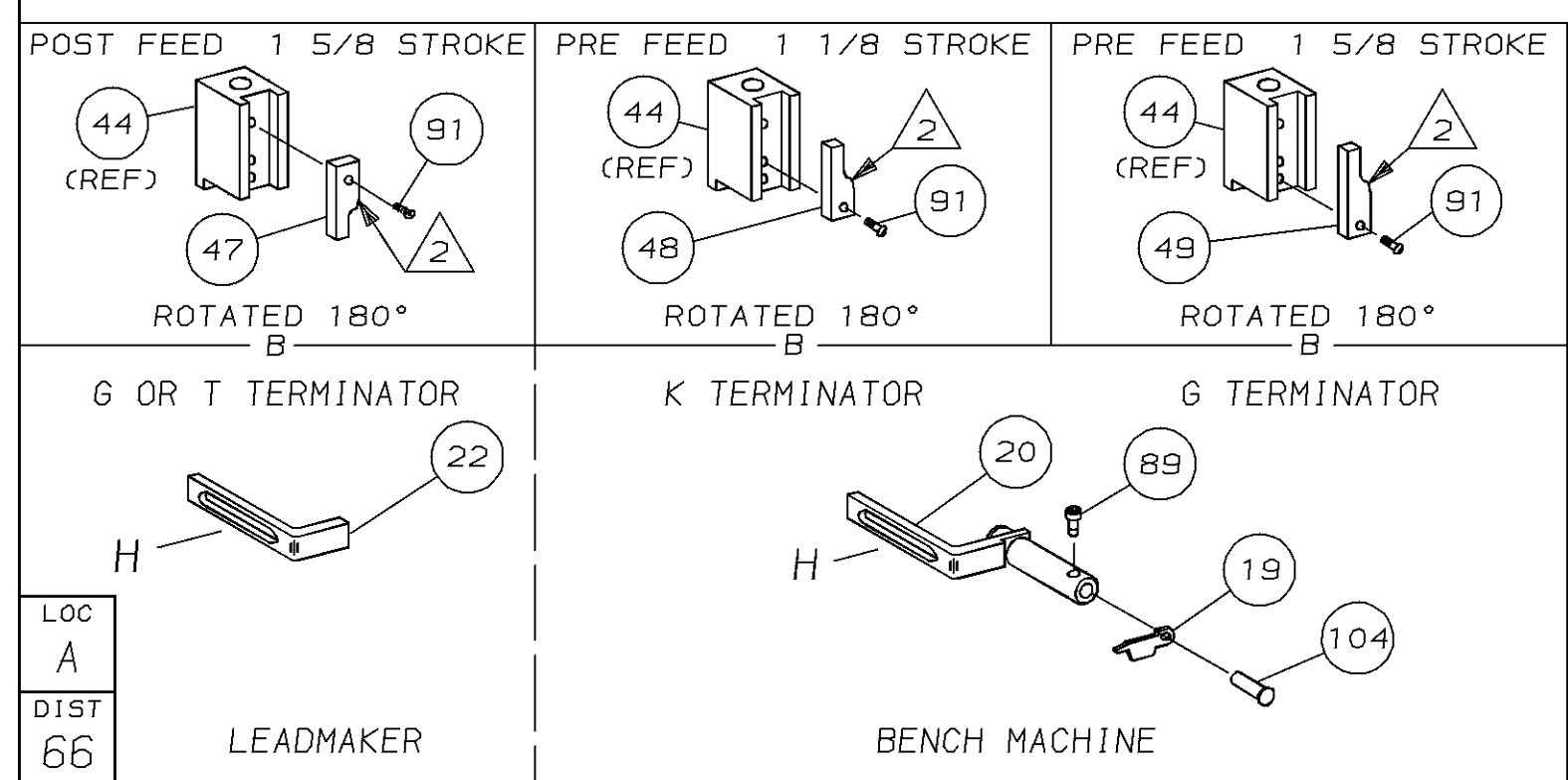
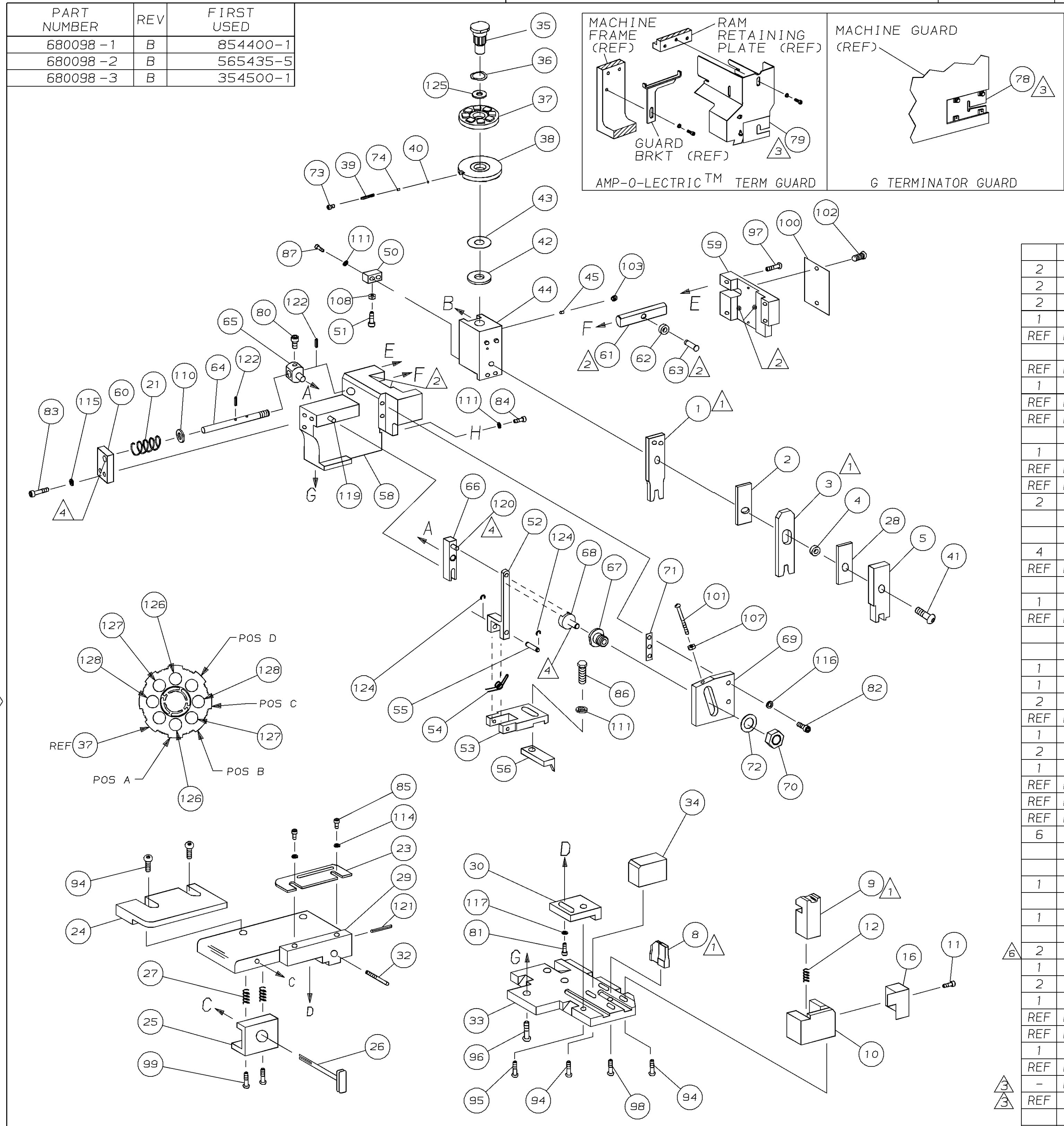

- 1 RECOMMENDED SPARE PARTS.
- 2 GREASE LIGHTLY.
- 3 GUARD MUST BE IN PLACE WHEN OPERATING APPLICATOR IN A BENCH MACHINE.
- 4 LUBRICATE DAILY USING NO. 20 MACHINE OIL.
- 5. ITEMS WITH QTY OF REF SPECIFIED (EXCEPT ITEMS 78 AND 79) ARE USED ON ITEM 46.
- 6 CUT TO LENGTH AT ASSY.
- 7 THIS APPLICATOR DOES NOT CUT CARRIER STRIP.

TERMINAL NAME: MICRO TIMER CONTACT

QTY REQD PER ASSY	U/M	DWG SIZE	PART NO	DESCRIPTION	ITEM NO
1			929952		

CRIMPING DATA

PAD LTR	CRIMP HEIGHT	WIRE SIZE
A	.054 ± .002	1mm <sup>2</sup>
B	.050 ± .002	0.75mm <sup>2</sup>
C	.046 ± .002	0.5mm <sup>2</sup>
D	NOT	USED

CRIMP	SIZE	TYPE	RANGE
WIRE	.080	F	0.5mm <sup>2</sup> -1mm <sup>2</sup>
INSUL	.100	0	2mm MAX
FEED	.472	APPL INST	SET UP GAGE LAYOUT
		408-8040	458637-1 L1580
			WIRE STRIP LENGTH -

	-1	LEADMAKER	MECH POST FEED		
	-2	BENCH MODEL K	MECH PRE FEED		
	-3	BENCH MODEL G	MECH PRE FEED		

QTY REQD PER ASSY	U/M	DWG SIZE	PART NO	DESCRIPTION	ITEM NO	
2			3-354779-0	PIN, WIRE DISC (.3140)C	129	
2			2-354779-2	PIN, WIRE DISC (.3100)B	128	
2			1-354779-4	PIN, WIRE DISC (.3060)A	126	
1			986950-1	WASHER, FLAT PRECISION	125	
REF	REF	REF	- A	21045-3	RING, RET °C (ø.187)FD FING PIN	124
REF	REF	REF	- A	5-21028-1	PIN, SLT SPR (ø.125x.50)ADJ ROD	123
1			4-21028-0	PIN, SLT SPR (ø.093x.75)ST GDE PL	121	
REF	REF	REF	- A	1-21030-1	PIN, DOWEL (ø.187x.50)LEVER	120
REF	REF	REF	- A	1-21030-6	PIN, DOWEL (ø.187x1.25)HOUSING	119
					118	
1			21024-5	WASHER, LOCK (#10)ADJ BLOCK	117	
REF	REF	REF	- A	21024-5	WASHER, LOCK (#10)ADJ PLATE	116
REF	REF	REF	- A	21024-5	WASHER, LOCK (#10)FEED GDE ROD	115
2			21024-2	WASHER, LOCK (#4)FRONT STP GUIDE	114	
					113	
					112	
4			21024-4	WASHER, LOCK (#8)STRIPPER	111	
REF	REF	REF	- A	21899-4	WASHER, FLAT (ø5/16)SCREW ADJ	110
					109	
1			21018-5	NUT, HEX (NO. 6)HOLDDOWN	108	
REF	REF	REF	- A	21018-5	NUT, HEX (6-32)FEED ADJ	107
					106	
					105	
1			992031-1	PIN, CLEVIS	104	
1			21009-2	SCR, SKT SET (1/4-20x.25 LW)RAM	103	
2			21017-2	SCR, DRIVE (#2x.19)ID PLATE	102	
REF	REF	REF	- A	6-23715-5	SCR, PAN HD (6-32x1.50)FEED ADJ	101
1			461264-1	PLATE, IDENTIFICATION	100	
2			3-21002-0	SCR, BHC (10-32x.88)DRAG	99	
1			22733-8	SCR, BHC (8-32x.38 LW)ANVIL	98	
REF	REF	REF	- A	2-21002-9	SCR, BHC (10-32x.75)CAP	97
REF	REF	REF	- A	2-22733-8	SCR, BHC (1/4-20x.62)HOUSING	96
REF	REF	REF	- A	2-21002-7	SCR, BHC (10-32x.50)SG ADJ BLOCK	95
6			2-21002-2	SCR, BHC (8-32x.50)SHEAR	94	
					93	
					92	
1			1-21002-7	SCR, BHC (6-32x.38)CAM	91	
					90	
1			7-21000-9	SCR, SHC (4-40x.19)STRIPPER	89	
					88	
2			2-21000-7	SCR, SHC (8-32x.48)DEP-HOLD	87	
1			2-22603-0	SCR, HEX HD (8-32x.31)FEED FINGER	86	
2			1-21000-3	SCR, SHC (4-40x.25)F ST GUIDE	85	
1			2-21000-7	SCR, SHC (8-32x.50)STRIPPER	84	
REF	REF	REF	- A	3-21000-7	SCR, SHC (10-32x.75)FEED ROD GD	83
REF	REF	REF	- A	3-21000-6	SCR, SHC (10-32x.62)FD ADJ BLK	82
1			3-21000-4	SCR, SHC (10-32x.38)SG ADJ BL	81	
REF	REF	REF	- A	3-21000-4	SCR, SHC (10-32x.38)PIVOT BLK	80
- REF				455749-1	GUARD, WINDOW	79
REF				679532-1	INSERT, GUARD	78
					77	
					76	
					75	
1			690603-1	SPRING, ASSIST	74	
1			23030-1	SCR, SHC (6-32x.25 SL)INS DISC	73	
REF	REF	REF	- A	458109-1	WASHER, SPECIAL	72
REF	REF	REF	- A	690517-1	SPACER	71
-3	-2	-1	U/M	DWG SIZE	PART NO	
					DESCRIPTION	
					ITEM NO	
QTY REQD PER ASSY				REVISION OF EACH ASSY NO (WHEN BLANK, USE DWG REVISION)		
				PARTS LIST		

	-1	LEADMAKER	MECH POST FEED			
	-2	BENCH MODEL K	MECH PRE FEED			
	-3	BENCH MODEL G	MECH PRE FEED			
REF	REF	REF	- B	22594-8	NUT, HEX (1/2-20)	70
REF	REF	REF	- B	240628-1	PLATE, ADJUSTMENT	69
REF	REF	REF	- B	240626-1	SHAFT, PIVOT	68
REF	REF	REF	- B	240633-1	BUSHING	67
REF	REF	REF	- A	455680-1	LEVER, INTERMEDIATE	66
REF	REF	REF	- B	240629-1	BLOCK, PIVOT	65
REF	REF	REF	- A	240632-2	SCREW, ADJ FEED ROD	64
REF	REF	REF	- B	240659-3	PIN, CAM ROLLER	63
REF	REF	REF	- B	240658-1	ROLLER, CAM	62
REF	REF	REF	- B	454398-2	ROD, FEED	61
REF	REF	REF	- A	454178-1	GUIDE, FEED ROD	60
REF	REF	REF	- C	454220-1	CAP, RAM	59
REF	REF	REF	- D	454485-1	HOUSING	58
						57
1			- B	690542-2	PAWL, FEED	56
REF	REF	REF	- B	240624-1	PIN, FEED FINGER	55
REF	REF	REF	- B	691499-1	SPRING, FEED FINGER	54
REF	REF	REF	- B	690541-1	HOLDER, FEED FINGER	53
REF	REF	REF	- A	455679-1	LEVER, TERMINAL FEED ARM	52
1			- A	811242-2	BUMPER, HOLDDOWN	51
1			- A	690753-1	SPACER, TONKER	50
1			- B	690602-6	CAM, PRE-FEED 1 5/8 ST	49
-	-	-	- B	690602-5	CAM, PRE-FEED 1 1/8 ST	48
-	-	-	- B	690501-4	CAM, POST-FEED 1 5/8 ST	47
1			- B	459456-1	APPLICATOR, BASIC (SUBASSY)	46
1			- A	690191-1	PLUG, NYLON	45
1			- C	455673-1	RAM	44
1			- A	690125-1	WASHER, LAMINATED	43
1			- A	690124-1	WASHER, RAM	42
1			- A	7-21002-9	BOLT, CRIMPER (5/16x1.00)	41
1			- A	23241-6	BALL, STEEL	40
1			- A	690170-1	SPRING, COMPRESSION	39
1			- C	690142-1	DISC, INSULATION	38
1			- D	354777-1	WIRE DISC, PLASTIC	37
1			- A	22480-5	WASHER, SPRING	36
1			- B	690212-1	POST, RAM	35
1			- B	690786-3	SUPPORT, TERMINAL	34
REF	REF	REF	- D	455675-1	PLATE, BASE	33
1			- A	690432-3	SCREW, ADJUSTMENT	32
						31
REF	REF	REF	- B	455689-1	BLOCK, STRIP GUIDE ADJ	30
1			- C	455671-1	PLATE, STRIP GUIDE	29
1			- C	2-455888-2	SPACER, FRONT SHEAR DEP	28
2			- A	1-22284-0	SPRING, DRAG	27
1			- B	690546-1	LEVER, DRAG RELEASE	26
1			- B	240792-1	DRAG, TERMINAL	25
1			- D	6-690504-8	GUIDE, STRIP (REAR)	24
1			- A	690438-1	GUIDE, STRIP (FRONT)	23
-	-	-	- B	690472-2	STRIPPER	22
REF	REF	REF	- A	4-22284-9	SPRING, FEED RETURN	21
1			- A	679218-1	STRIPPER WIRE STOP ASSY	20
1			- B	458949-1	STRIPPER	19
						18
						17
1			- B	691667-1	GUARD, CHIP (FRONT)	16
						15
						14
						13
1			- A	5-22280-0	SPRING, SHEAR	12
1			- B	690461-1	STOP, SHEAR	11
1			- C	679625-1	HOLDER, SHEAR (FRONT)	10
1			- C	454276-2	SHEAR, FLOAT (FRONT)	9
1			- C	9-854014-8	ANVIL	8
						7
						6
1			- C	1-455889-4	DEPRESSOR, SHEAR (FRONT)	5
1			- B	238011-4	SPACER, BLOCK CRIMPER	4
1			- C	9-456135-6	CRIMPER, INSULATION	3
1			- C	455888-3	SPACER, CRIMPER	2
1			- C	1-456405-5	CRIMPER, WIRE	1
-3	-2	-1	U/M	DWG SIZE	PART NO	
					DESCRIPTION	
					ITEM NO	
QTY REQD PER ASSY				REVISION OF EACH ASSY NO (WHEN BLANK, USE DWG REVISION)		
				PARTS LIST		

DIMENSIONS IN INCHES. DO NOT SCALE PRINT. TOLERANCES UNLESS OTHERWISE SPECIFIED.

DR 5/27/94 APP 5-27-94  
M. O'BRINE T. ELBIN

CHK 5-27-94 REL 9/13/94  
C. ERISMAN B. MORGAN

AMP Incorporated  
Harrisburg, PA 17105-3608

NAME: **SIDE FEED HDM APPLICATOR** MACHINE REF: **MINI APPL**

SCALE: **D** DWG NO: **680098** SHEET 1 OF 1 REV B

THIS INFORMATION IS CONFIDENTIAL AND IS DISCLOSED TO YOU ON CONDITION THAT NO FURTHER DISCLOSURE IS MADE BY YOU TO OTHER THAN AMP PERSONNEL WITHOUT WRITTEN AUTHORIZATION FROM AMP INCORPORATED, HARRISBURG, PA.