

LOC		DIST		REVISIONS			
ZONE	LTR	DESCRIPTION	DATE	APPD			
AF	50			C	ECR-13-008483	06AUG13	JX/DZ

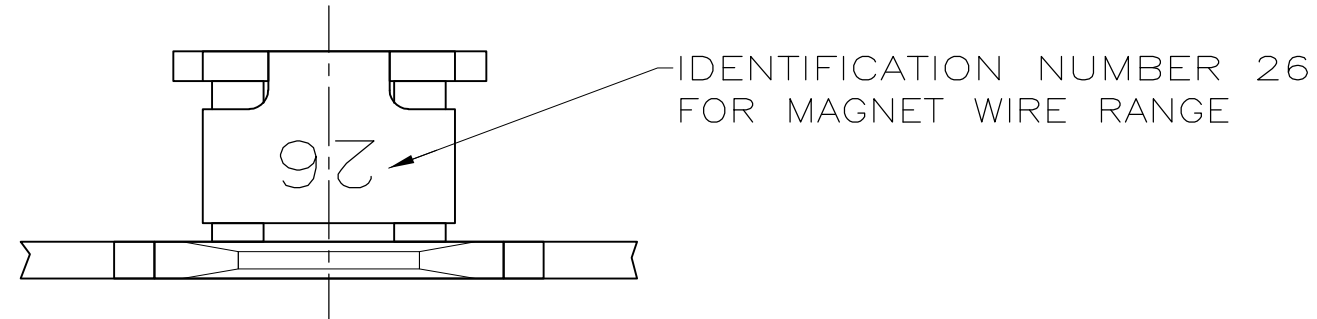

- 1 CONTINUOUS STRIP ON REELS WITH TERMINALS LOCATED ON 8.38±0.08 [.330±.003] CENTERS.
- 2 SLOT TERMINATES A SINGLE 0.81-1.02mm [#20-#18] AWG BARE SOLID COPPER WIRE.
- 3 AFTER INSERTION INTO PLASTIC HOLDER TAB PORTION MUST BE BENT OVER 45° TO 90° OR POTTED-IN TO PREVENT PULL-OUT WHEN MATING RECEPTACLE IS DISCONNECTED.
- 4 SLOT ALSO TERMINATES A SINGLE 0.81mm [#20] AWG OR A 0.81 [.032] DIA COPPER CLAD STEEL WIRE PER ASTM B452-67 CLASS 40 A.

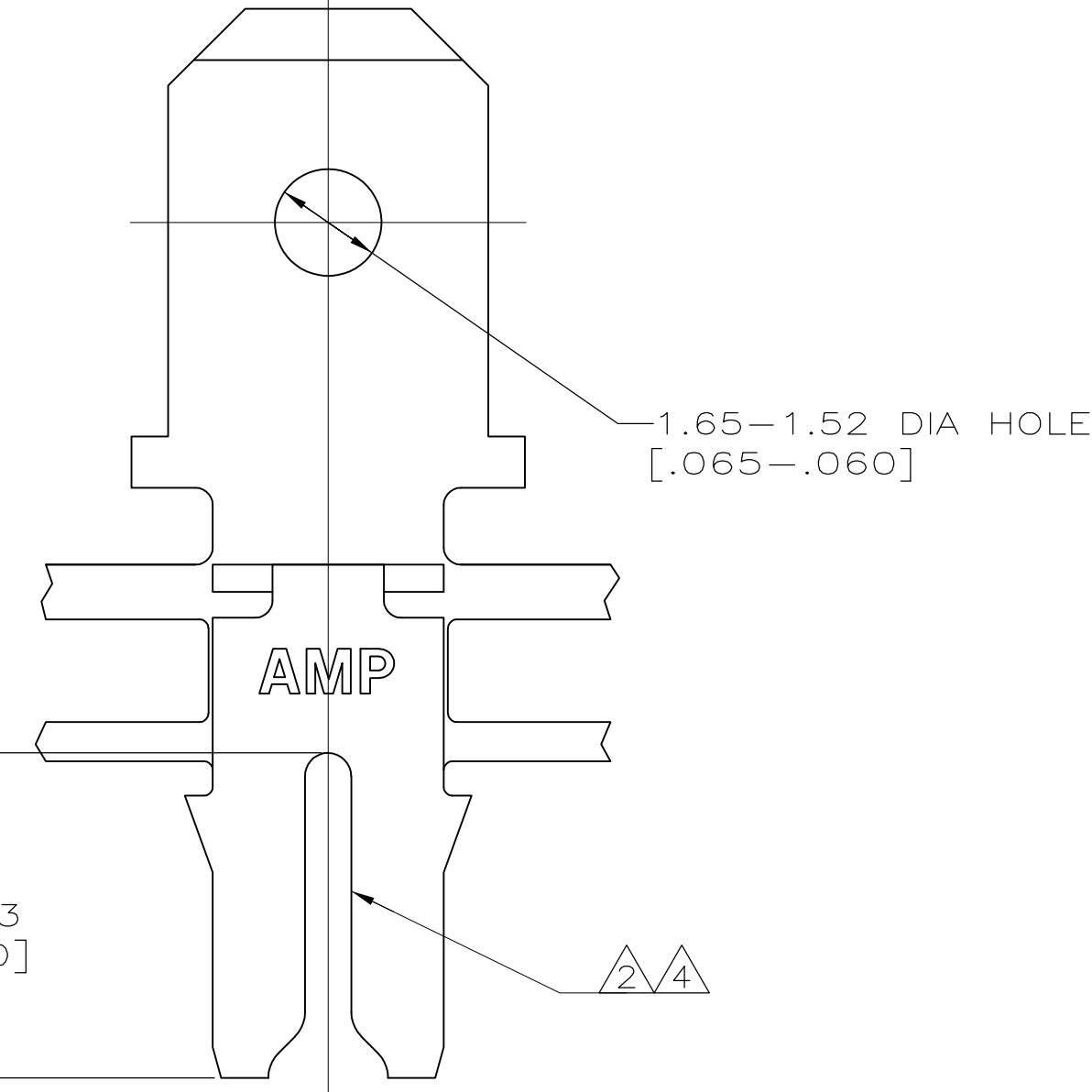
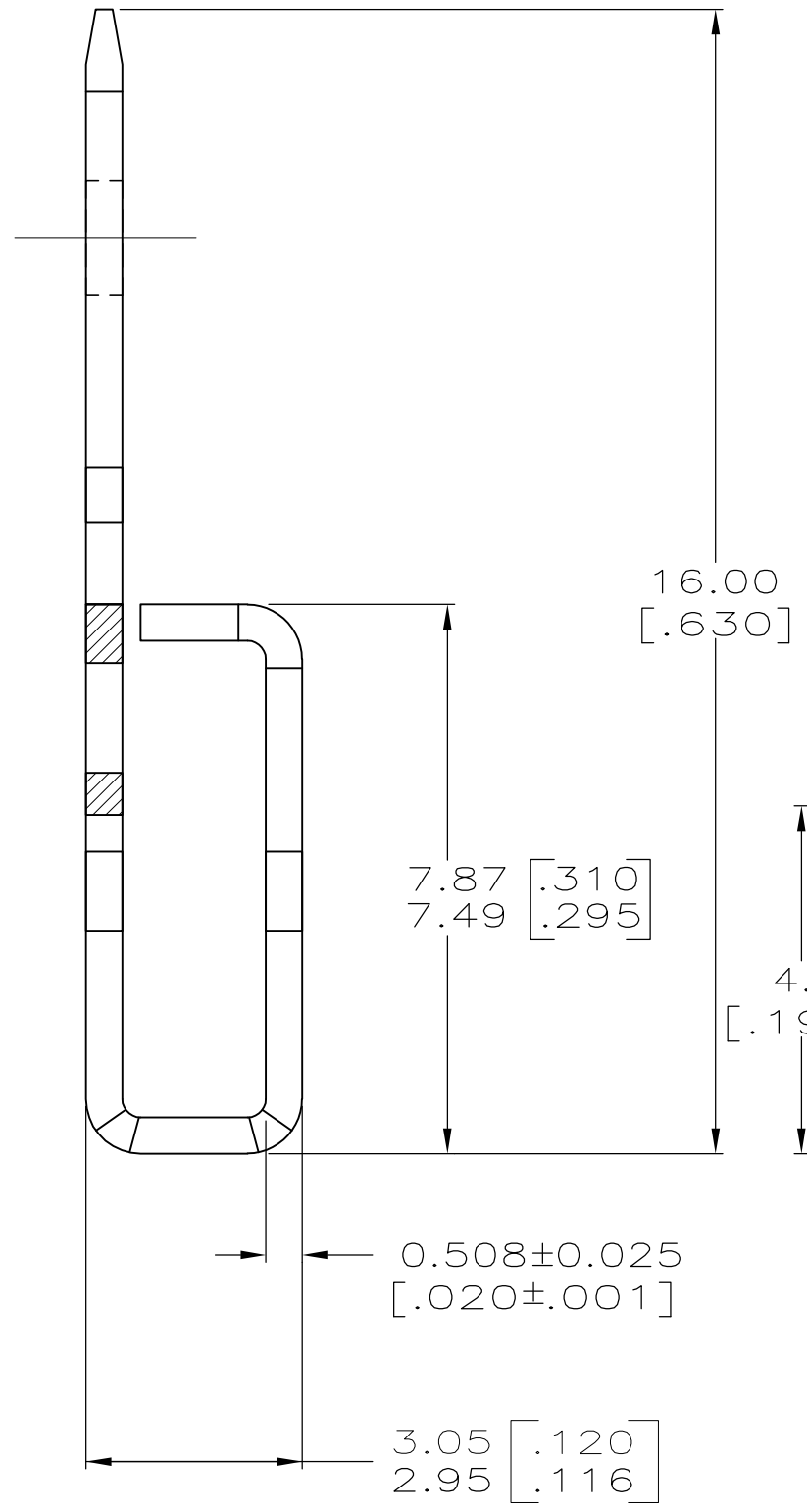
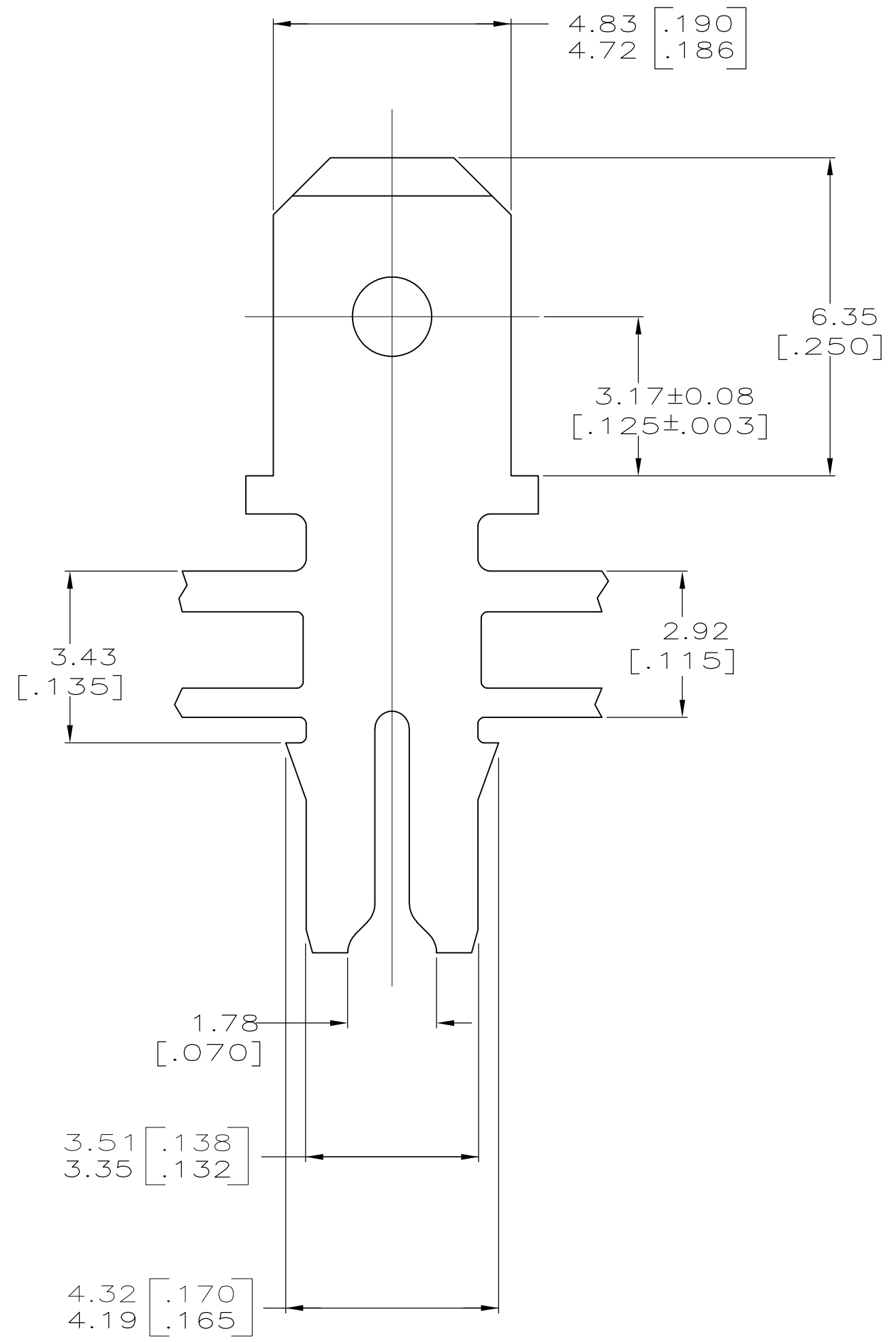

63670-1
PART NO

DO NOT SCALE PRINT. UNLESS SPECIFIED DIMENSIONS IN mm [INCHES] TOLERANCES ON : 2 PLC DEC ± 0.25 [.010] 3 PLC DEC ± - ANGLES ± -	DR 9/4/92 MICHAEL S. FEHER	AMP Incorporated Harrisburg, PA 17105-3608	NAME	TERMINAL, TAB, 4.75 [.187] FASTON, MAG-MATE			
	CHK 9/7/92 JEFF R. RUTH			APPD 9/15/92 NELSON E. NEFF	APPD 9/15/92 TERRY L. SHUTTER	PRODUCT SPEC 108-2012	SIZE C
MATERIAL H03 BRASS	FINISH TIN PLATE	APPLICATION SPEC 114-2046	WEIGHT -	SCALE 10:1	SHEET 10F 1		

THIS DRAWING IS A CONTROLLED DOCUMENT FOR AMP INCORPORATED. IT IS SUBJECT TO CHANGE AND THE CONTROLLING ENGINEERING ORGANIZATION SHOULD BE CONTACTED FOR THE LATEST REVISION.