

**【 DIMENSIONS OF CONNECTOR 】**

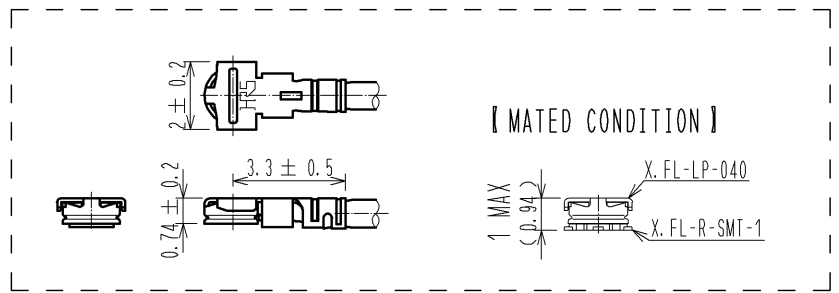

**【 PRECAUTIONS FOR HANDLING 】**

◆ Connector insertion and extraction

a. Insert the connector as perpendicularly to the mating surface as possible with aligning the mating axes of both connectors by specialised insertion JIG.

Part No. : X.FL-LP-IN. OUT1 (CL331-0715-2)

Do not excessively slant the connectors when inserting.

b. Connector shall be extracted by specialised extraction JIG.

Part No. : X.FL-LP-IN. OUT1 (CL331-0715-2)

Never hold the cable when extracting the cable because it damages the connector.

◆ Allowable loads on the cable after the connectors are mated.

The right figures show the maximum allowable loads on the cable.

Do not apply loads exceeding these values to the cable.

◆ Please don't apply the power of the direction which lifts a cable.

There is a danger that the inserted-in plug will separate.

When you perform wiring which curves a cable as shown in the left figure, please be careful.

◆ We recommend you to arrange a cushioning medium,

as shown in a figure, and to prevent a fitting blank.

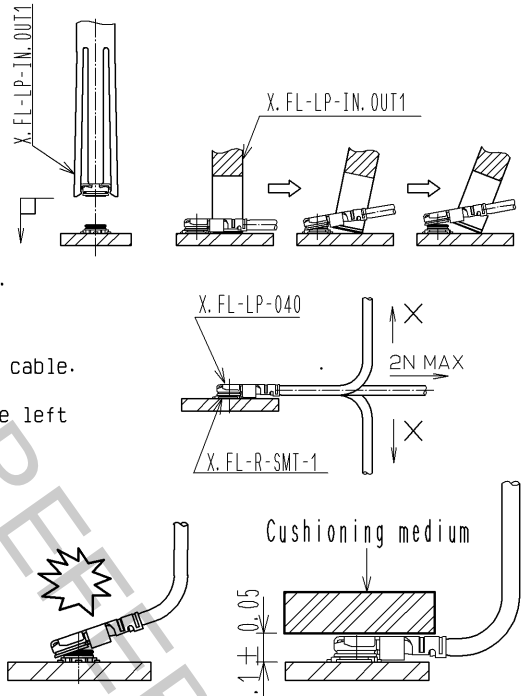

**RoHS COMPLIANT  
HALOGEN FREE**

1	X.FL-LP-040	CL331-0700-5	2	FWS5033(WHITE)	KURABE INDUSTRIAL CO., LTD.		
NO.	PART NO.	CODE NO.	NO.	PART NO.	MANUFACTURER		
UNITS mm		SCALE FREE	COUNT 	DESCRIPTION OF REVISIONS	DESIGNED	CHECKED	DATE
<b>HRS</b> HIROSE ELECTRIC CO., LTD.	APPROVED	: NK. NINOMIYA	14. 04. 25	DRAWING NO.	EDC4-357739-03		
	CHECKED	: MT. KANEKO	14. 04. 24	PART NO.	X.FL-2LP-04K1T-AC-(50)		
	DESIGNED	: MS. MATSUMOTO	14. 04. 22	CODE NO.	CL321-6173-7-03		
	DRAWN	: MS. MATSUMOTO	14. 04. 22		1/1		