

Apr.1.2017 Copyright 2017 HIROSE ELECTRIC CO., LTD. All Rights Reserved.

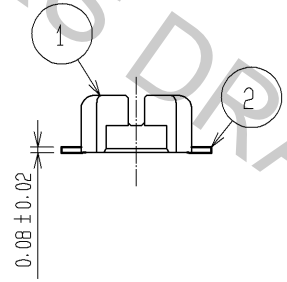

RECOMMENDED METAL MASK  
OPENING PATTERN

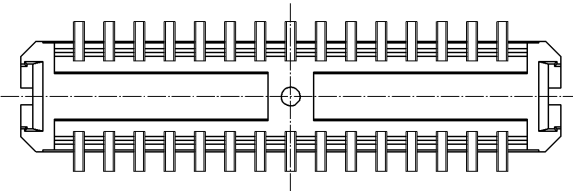
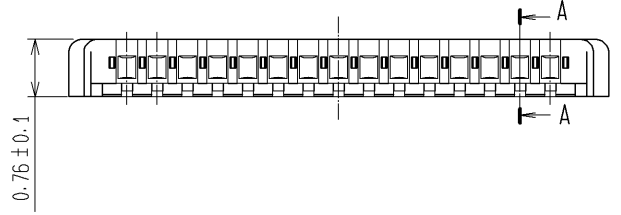
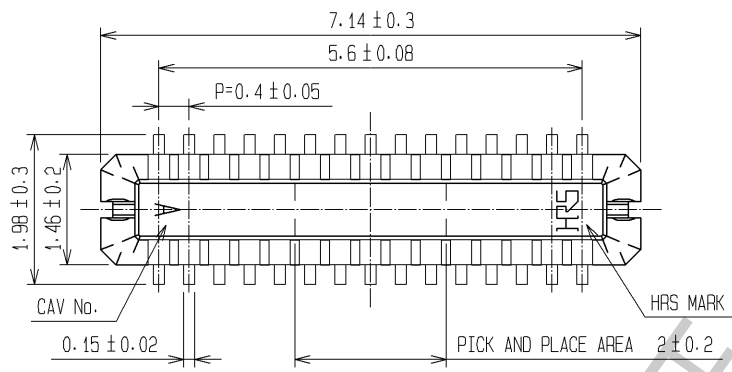
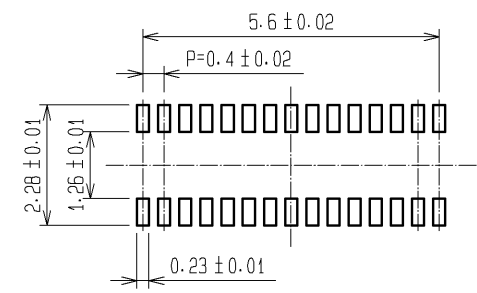

RECOMMENDED PATTERN

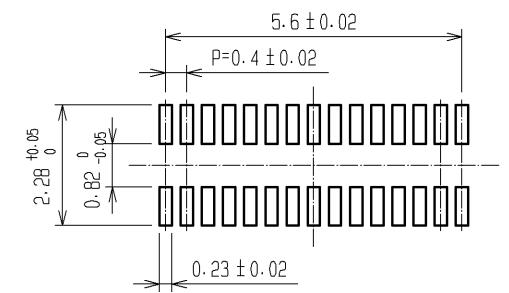

RECOMMENDED SOLDER PASTE THICKNESS: 120#m

ENGAGEMENT FIGURE

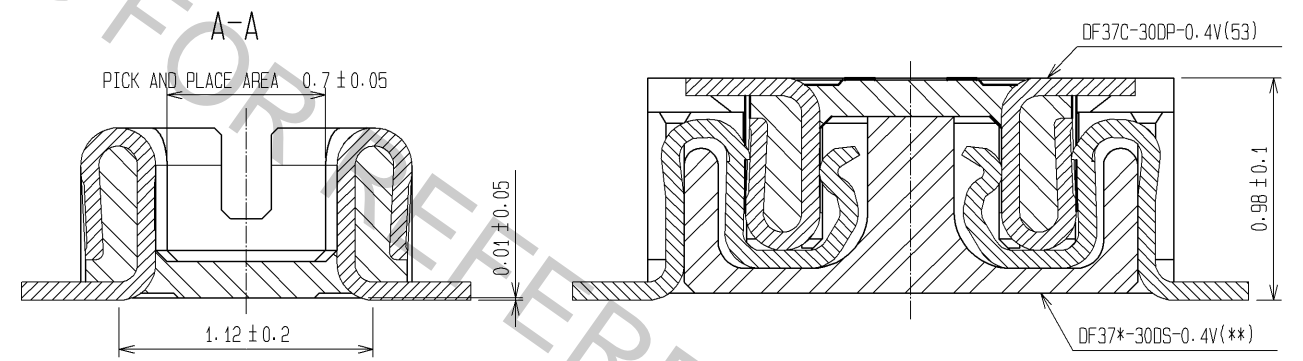

- NOTE 1. ALL LEADS CO-PLANARITY SHALL BE 0.1 MAX.  
 2. PER REEL : 1000 CONNECTORS.  
 3. AT THE BEGINNING OF THE REEL, 100 mm AT MIN SHALL BE EMPTY POCKETS.  
 AT THE END OF THE REEL, 160 mm AT MIN SHALL BE EMPTY.  
 4. CONTACT PLATING SPECIFICATIONS.  
 CONTACT AREA : GOLD 0.05#m MIN.  
 SMT LEAD : GOLD 0.05#m MIN.  
 UNDERPLATING : NICKEL 1#m MIN.  
 (SURFACE : SEALING)  
 5. PEEL FORCE OF COVER TAPE REFERS TO JIS C 0806.

2	PHOSPHOR BRONZE	4	5	PS	PLASTIC REEL (BLACK)
1	LCP	UL94V-0, BLACK	4	POLYESTER	CLEAR(COVER TAPE)
			3	PS	CLEAR(EMBOSSED CARRIER TAPE)
NO.	MATERIAL	FINISH, REMARKS	NO.	MATERIAL	FINISH, REMARKS
UNITS	mm	SCALE	FREE	COUNT	DESCRIPTION OF REVISIONS
					DESIGNED
					CHECKED
					DATE
APPROVED : KH. IKEDA		08.12.25	DRAWING NO. EDC3-308601-02		
CHECED : TS. MIYAZAKI		08.12.25	PART NO. DF37C-30DP-0.4V(53)		
DESIGNED : RT. SHIMIZU		08.12.24	CODE NO. CL684-3026-3-53		
DRAWN : AK. AOYAGI		08.12.24			

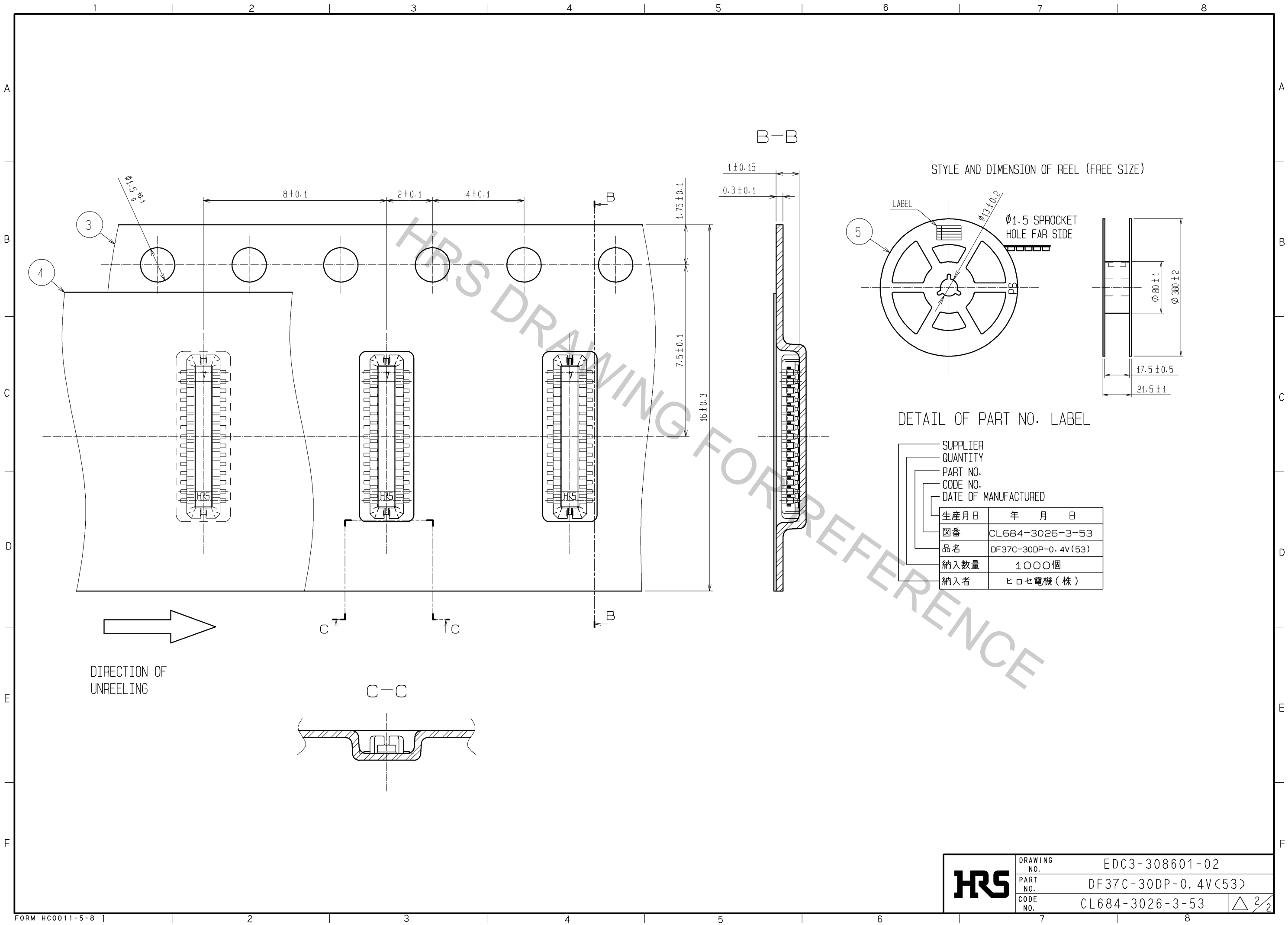

DETAIL OF PART NO. LABEL

SUPPLIER	
QUANTITY	
PART NO.	
CODE NO.	
DATE OF MANUFACTURED	
生産月日	年 月 日
図番	CL684-3026-3-53
品名	DF37C-30DP-0.4V(53)
納入数量	1000個
納入者	ヒロセ電機(株)

<b>HRS</b>	DRAWING NO.	EDC3-308601-02
	PART NO.	DF37C-30DP-0.4V(53)
	CODE NO.	CL684-3026-3-53
		△ 2/2