

LOC		DIST		P		F		ZONE		LTR		REVISIONS		DATE	APPD
AF		50								A		RELEASE PER FASR & 0710-0544-95	30/NOV/95	PF/DD	

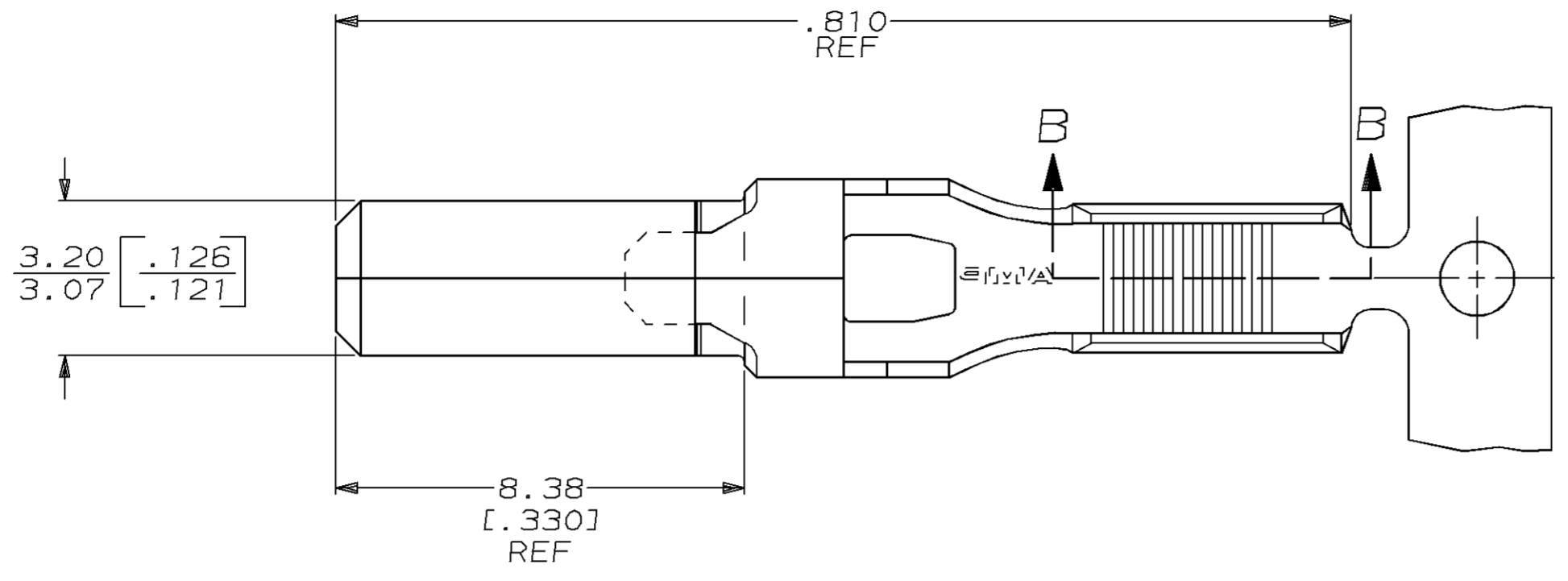

1 CONTINUOUS STRIP ON REEL.

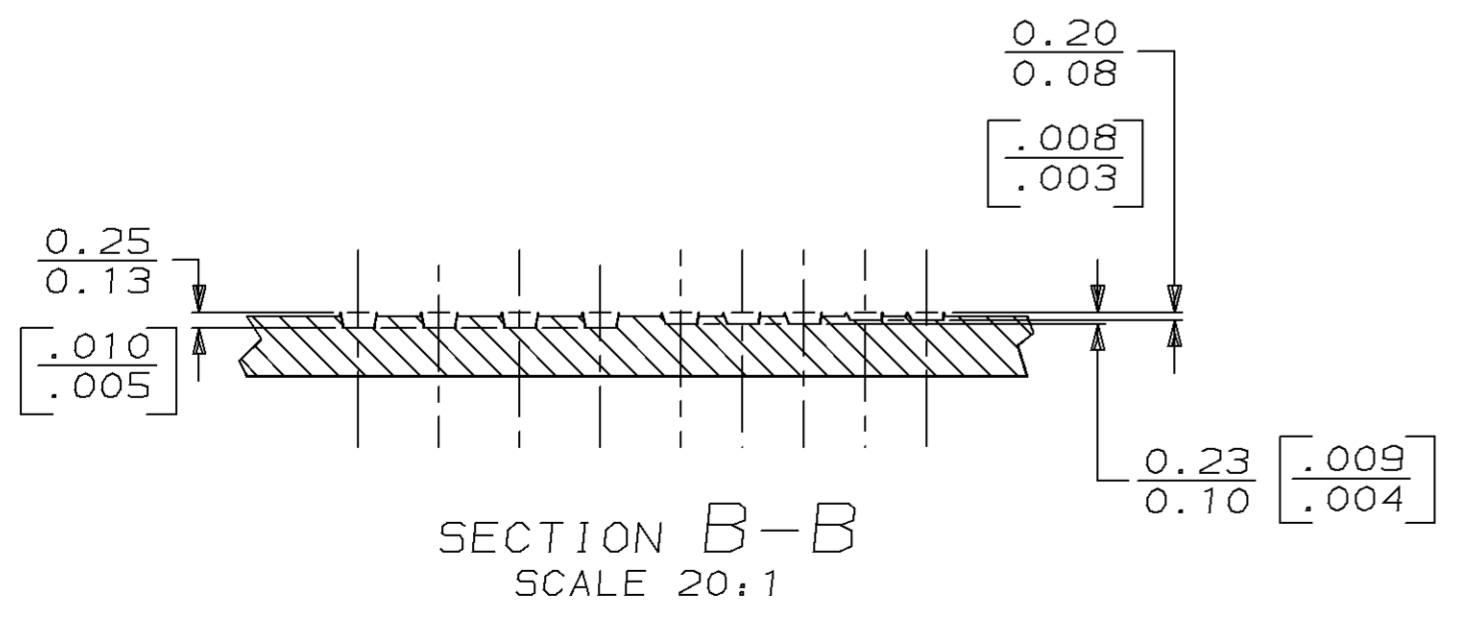
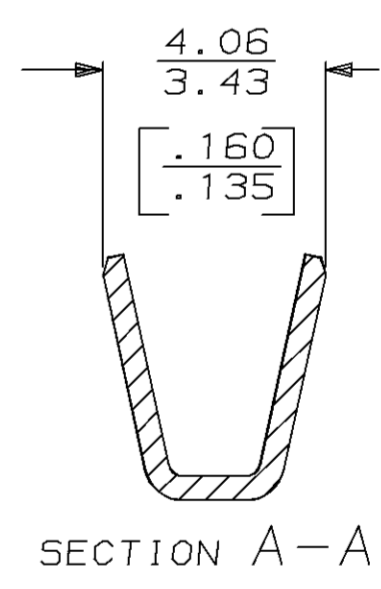
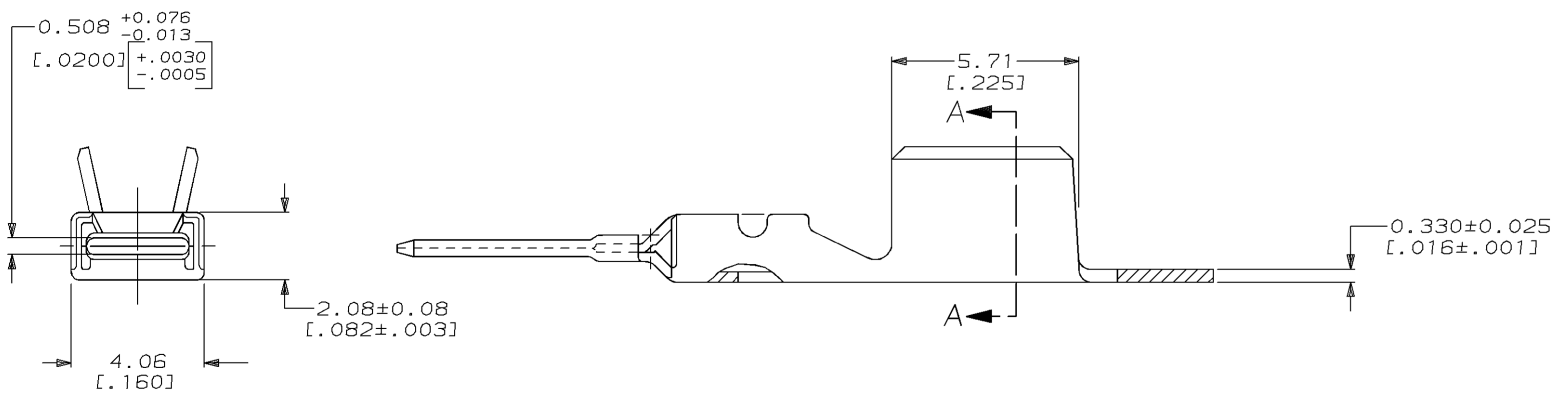

1500-5000 CMA	63870-1
WIRE RANGE	PART NO

DO NOT SCALE PRINT. UNLESS SPECIFIED DIMENSIONS IN mm [INCHES] TOLERANCES ON: 2 PLC DEC ± 0.25 [0.10] 3 PLC DEC ± - ANGLES ± -	DR 13/SEP/95 PHILLIP M FORTNEY	AMP Incorporated Harrisburg, PA 17105-3608	
	CHK 13/SEP/95 JEFF RUTH		
MATERIAL 4M BRASS	APPD 13/SEP/95 DON DECKER	NAME CONTACT, 3.18 [0.125] BLADE, AMPLIVAR	
FINISH 0.002032 [0.000080] MIN TIN PL PER MIL-T-10727	APPD 13/SEP/95 MARK BARNABA	PRODUCT SPEC -	
	APPLICATION SPEC -	SIZE C 00779	DRAWING NO G=63870
	WEIGHT -	SCALE 8:1	SHEET 1 OF 1

THIS DRAWING IS A CONTROLLED DOCUMENT FOR AMP INCORPORATED. IT IS SUBJECT TO CHANGE AND THE CONTROLLING ENGINEERING ORGANIZATION SHOULD BE CONTACTED FOR THE LATEST REVISION.