

Aug.1.2018 Copyright 2018 HIROSE ELECTRIC CO., LTD. All Rights Reserved.  
 In case that the application demands a high level of reliability, such as automotive,  
 please contact a company representative for further information.

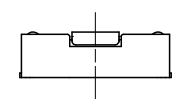
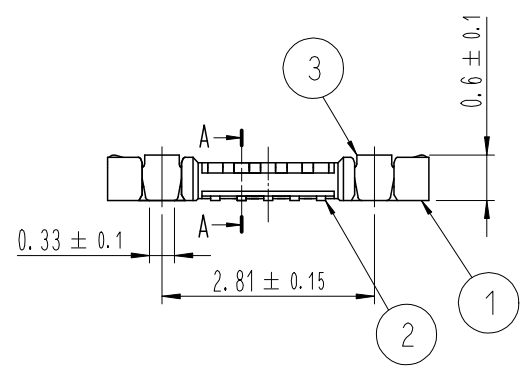
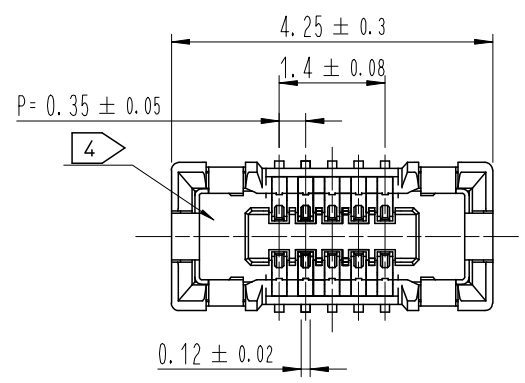

DRAWING FOR REFERENCE  
 This is subject to change without notice

- NOTE
- 1 . ALL LEAD CO-PLANARITY SHALL BE 0.08mm MAX.
  - 2 > CONTACT PLATING SPECIFICATIONS.  
 CONTACT AREA : GOLD 0.05 μm MIN.  
 SMT LEAD : GOLD 0.05 μm MIN.  
 UNDERPLATING : NICKEL 1 μm MIN.  
 ( SURFACE : SEALING )
  - 3 > MATAL FITTING PLATING SPECIFICATIONS.  
 SMT LEAD : GOLD 0.05 μm MIN.  
 UNDERPLATING : NICKEL 1 μm MIN.  
 ( SURFACE : SEALING )
  - 4 > HRS MARK AND CAV NO. ARE INDICATED IN APPROX POSITION SHOWN.

COUNT	DESCRIPTION OF REVISIONS	B	Y	CHKD	DATE	COUNT	DESCRIPTION OF REVISIONS	B	Y	CHKD	DATE
△						△					
△						△					
△						△					

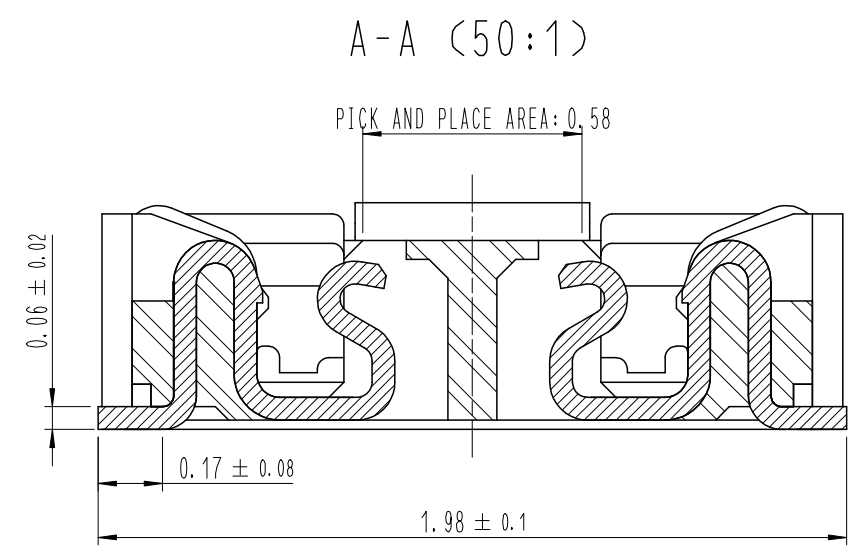

ENGAGEMENT FIGURE (50:1)

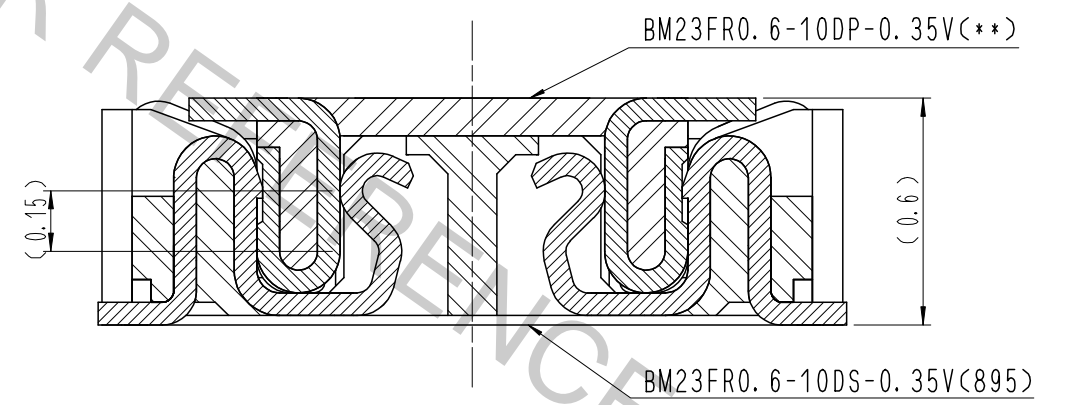

NO.	MATERIAL	FINISH , REMARKS	NO.	MATERIAL	FINISH , REMARKS
4	PS	CLEAR (EMBOSSED CARRIER TAPE)	7	PS	CLEAR (REINFORCEMENT COLLAR)
3	COPPER ALLOY	3 >	6	PS	BLACK (PLASTIC REEL)
2	COPPER ALLOY	2 >	5	POLYESTER	CLEAR (COVER TAPE)
1	LCP	UL94 V-0, BLACK			

REMARKS	DRAWN	DESIGNED	CHECKED	APPROVED	RELEASED
	S. H. JUNG 17. 05. 08	S. H. JUNG 17. 05. 08	H. W. JO 17. 05. 08	T. S. KANG 17. 05. 08	17. 05. 08

CODE NO. (OLD)	DRAWING NO. EDC3-631862	PART NO. BM23FR0.6-10DS-0.35V(895)
SCALE 10:1	HRS HIROSE KOREA CO., LTD.	CODE NO CL 6644-0011-0-895
UNITS mm		1/3

Aug.1.2018 Copyright 2018 HIROSE ELECTRIC CO., LTD. All Rights Reserved.  
 In case that the application demands a high level of reliability, such as automotive,  
 please contact a company representative for further information.

6 RECOMMENDED PCB LAYOUT

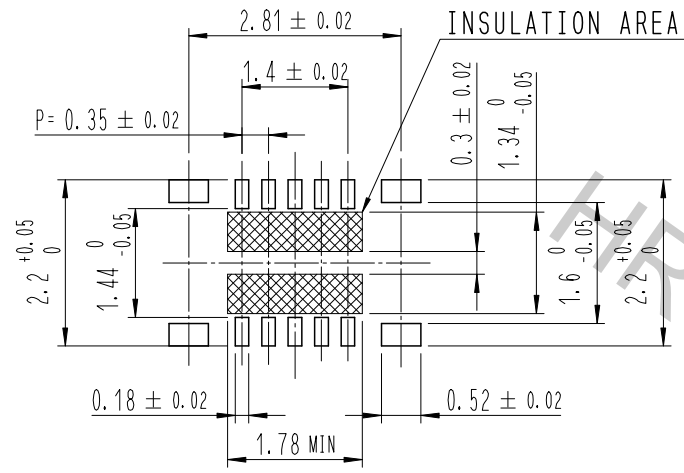

RECOMMENDED METAL MASK DIMENSIONS  
 METAL MASK THICKNESS : 100 μm

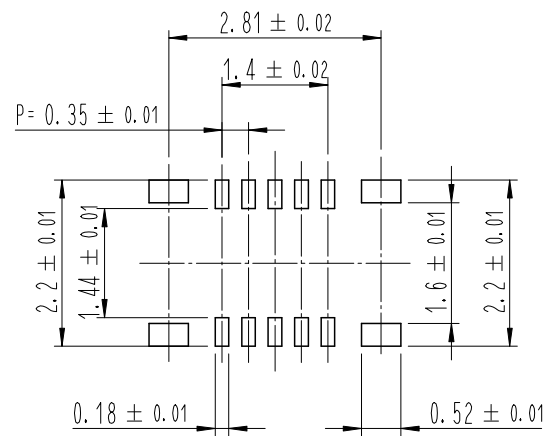

5 RECOMMENDED REFLOW TEMPERATURE PROFILE  
 USING LEAD-FREE SOLDER PASTE.

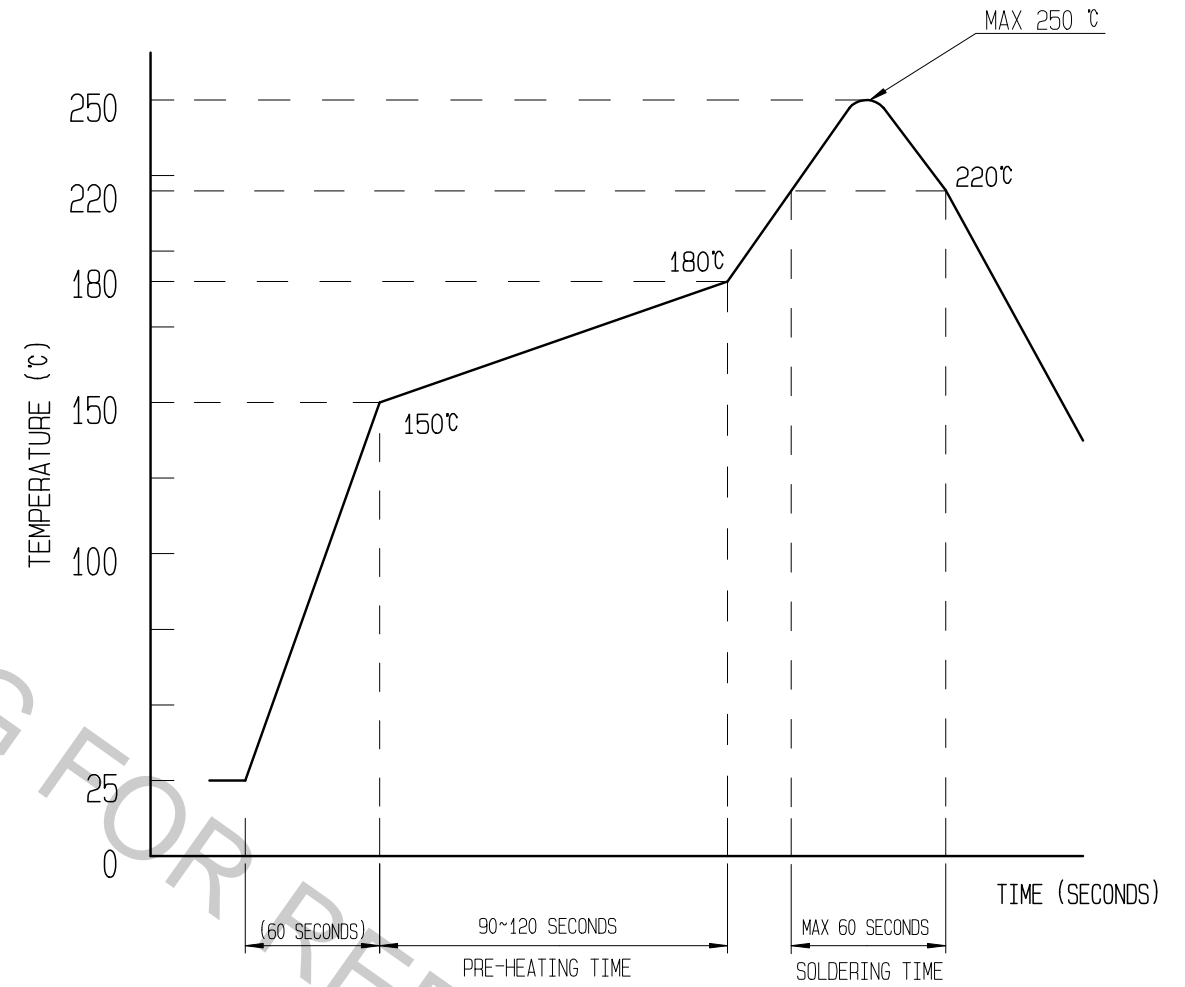

REFLOW METHOD: N2 REFLOW  
 NUMBER OF REFLOW CYCLES: 2 CYCLES MAX.  
 1) REFLOW TIME  
 DURATION ABOVE 220°C: 60 SEC MAX.  
 (PEAK TEMPERATURE: 250°C MAX)  
 2) PRE-HEAT TIME  
 PRE-HEAT TEMPERATURE (MIN): 150°C  
 PRE-HEAT TEMPERATURE (MAX): 180°C  
 PRE-HEAT TIME: 90-120 SEC.

- 5 THIS TEMPERATURE PROFILE IS PER THE CONDITIONS SHOWN ABOVE. ADDITIONAL FACTORS, SUCH AS SOLDER PASTE TYPE, PCB SIZE AND OTHER MOUNTED COMPONENTS COULD AFFECT THE PROFILE. THEREFORE, A THOROUGH EVALUATION OF MOUNTING CONDITION IS REQUIRED PRIOR TO PRODUCTION. TEMPERATURE IS MEASURED AT CONTACT LEAD.
- 6 PLEASE CONTACT US IN CASE YOU WILL MAKE DIFFERENT SETTINGS FROM OUR RECOMMENDATION.

	DRAWING NO.	EDC3-631862	PART NO.	BM23FR0.6-10DS-0.35V(895)
	SCALE	10:1	CODE NO	CL 6644-0011-0-895
UNITS	mm	HRS HIROSE KOREA CO., LTD.		2/3

Aug.1.2018 Copyright 2018 HIROSE ELECTRIC CO., LTD. All Rights Reserved.  
 In case that the application demands a high level of reliability, such as automotive,  
 please contact a company representative for further information.

STYLE AND DIMENTION OF REEL (FREE)

EMBOSED CARRIER TAPE PACKAGING (5:1)

C-C (5:1)

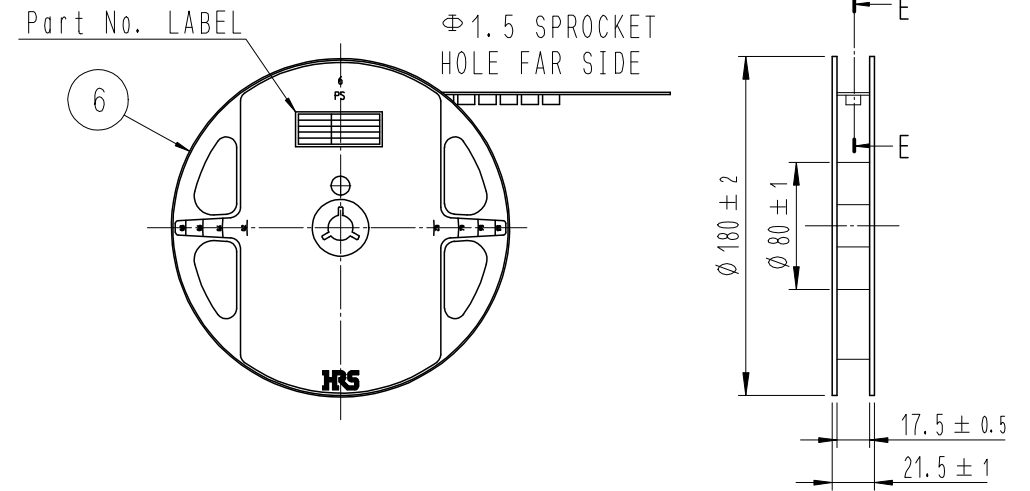
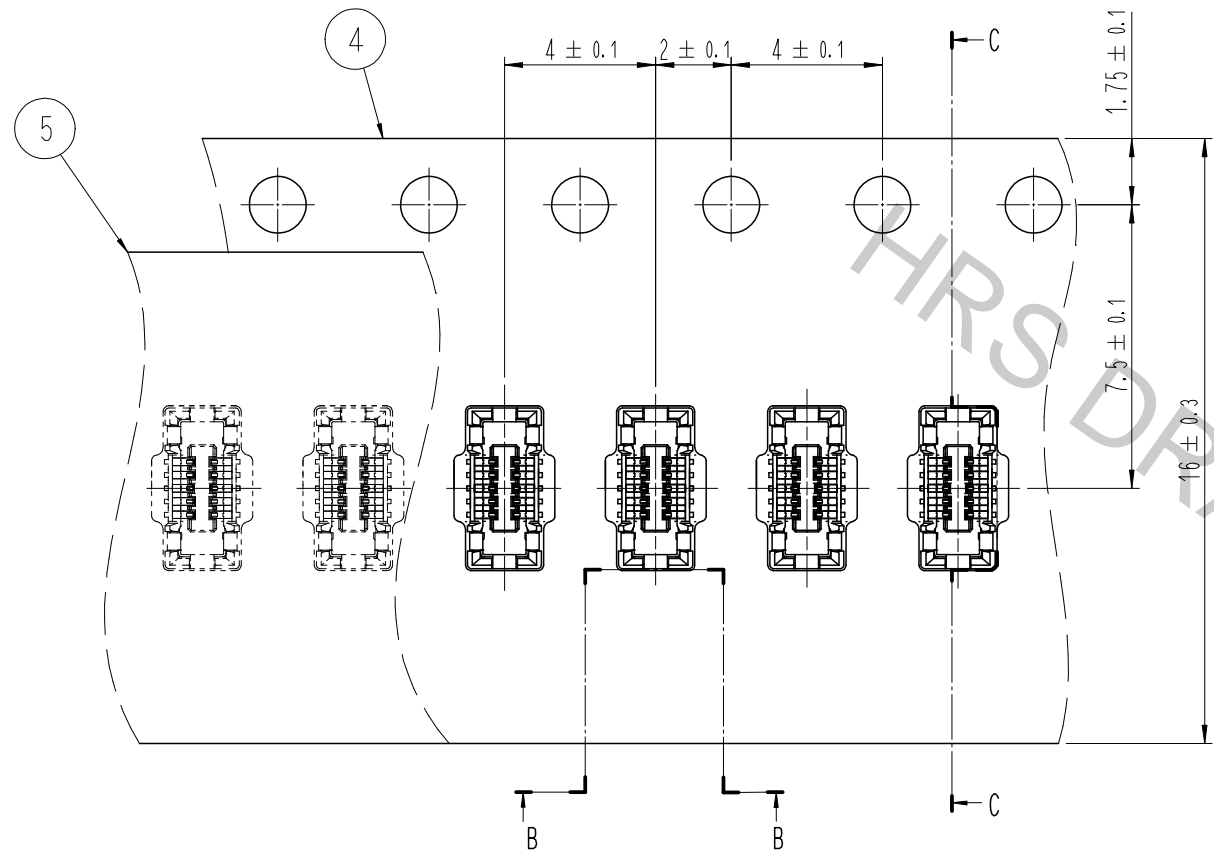

E-E (FREE)

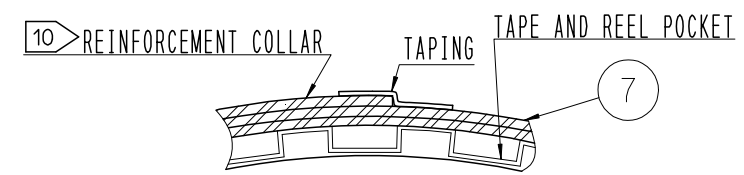

D (10:1)

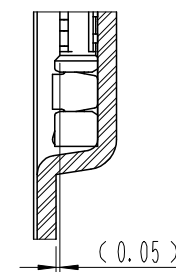

B-B (5:1)

DIRECTION OF UNREELING

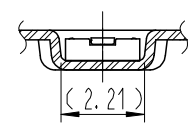

9 TAPING(FREE)

DETAIL OF PART No. LABEL

SUPPLIER	QUANTITY	PART NO.	CODE NO.	DATE OF MANUFACTURED
生産月日	年 月 日	図番	** ** *	
品名	BM23FR0.6-10DS-0.35V(895)			
納入数量	1,000個			
納入者	HIROSE KOREA			

7 . PER REEL 1,000 CONNECTORS.

8 . THE DIMENSIONS IN PARENTHESSES ARE FOR REFERENCE.

9 REFER TO JIS C 0806, IEC-60286-3 (PACKAGING OF COMPONENTS FOR AUTOMATIC HANDLING)

10 AFTER PACKAGING, ROLL 2 METERS OF THE REINFORCEMENT COLLAR TO OUTER CIRCUMFERENCE OF TAPE AND REEL POCKET. AND TAPE DOWN AT THE END THE COLLAR.

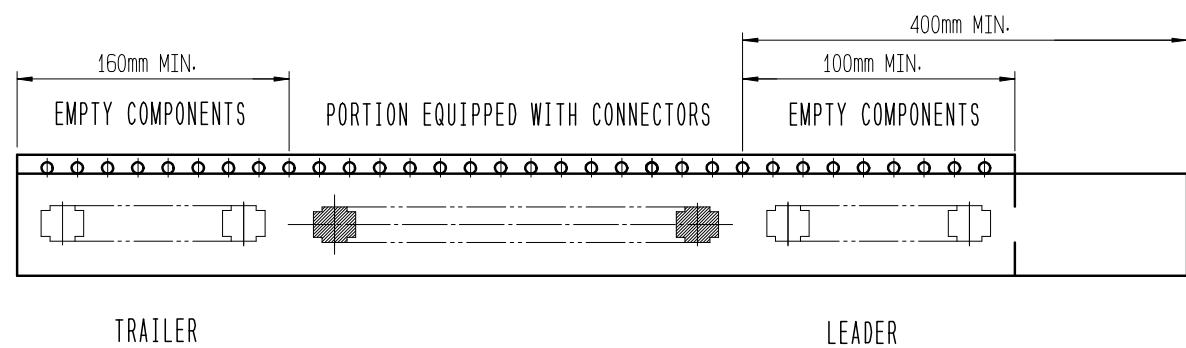

DRAWING NO. EDC3-631862	PART NO. BM23FR0.6-10DS-0.35V(895)	CODE NO. CL 6644-0011-0-895	3/3
HRS HIROSE KOREA CO., LTD.			