

Development Board EPC9001

Quick Start Guide

40 V Half-Bridge with Gate Drive, Using EPC2015



DESCRIPTION

www.epc-co.com

The EPC9001 development board is a 40 V maximum device voltage, 15 A maximum output current, half bridge with onboard gate drives, featuring the EPC2015 enhancement mode (*eGaN*[®]) field effect transistor (FET). The purpose of this development board is to simplify the evaluation process of the EPC2015 *eGaN FET* by including all the critical components on a single board that can be easily connected into any existing converter.

The EPC9001 development board is 2" x 1.5" and contains not only two EPC2015 *eGaN FET* in a half bridge configuration using

Texas Instruments LM5113 gate driver, supply and bypass capacitors. The board contains all critical components and layout for optimal switching performance. There are also various probe points to facilitate simple waveform measurement and efficiency calculation. A complete block diagram of the circuit is given in Figure 1.

For more information on the EPC2015s *eGaN FET* please refer to the datasheet available from EPC at www.epc-co.com. The datasheet should be read in conjunction with this quick start guide.

Table 1: Performance Summary (TA = 25°C)

SYMBOL	PARAMETER	CONDITIONS	MIN	MAX	UNITS
V _{DD}	Gate Drive Input Supply Range		7	12	V
V _{IN}	Bus Input Voltage Range			24*	V
V _{OUT}	Switch Node Output Voltage			40	V
I _{OUT}	Switch Node Output Current			15*	A
V _{PWM}	PWM Logic Input Voltage Threshold	Input 'High'	3.5	6	V
		Input 'Low'	0	1.5	V
	Minimum 'High' State Input Pulse Width	VPWM rise and fall time < 10ns	40		ns
	Minimum 'Low' State Input Pulse Width	VPWM rise and fall time < 10ns	160#		ns

* Assumes inductive load, maximum current depends on die temperature – actual maximum current will be subject to switching frequency, bus voltage and thermals.

Limited by time needed to 'refresh' high side bootstrap supply voltage.

Quick Start Procedure

Development board EPC9001 is easy to set up to evaluate the performance of the EPC2015 *eGaN FET*. Refer to Figure 2 for proper connect and measurement setup and follow the procedure below:

1. With power off, connect the input power supply bus to +VIN (J5, J6) and ground / return to -VIN (J7, J8).
2. With power off, connect the switch node of the half bridge OUT (J3, J4) to your circuit as required.
3. With power off, connect the gate drive supply to +VDD (J1, Pin-1) and ground return to -VDD (J1, Pin-2).
4. With power off, connect the input PWM control signal to PWM (J2, Pin-1) and ground return to any of the remaining J2 pins.
5. Turn on the gate drive supply – make sure the supply is between 7 V and 12 V range.
6. Turn on the bus voltage to the required value (do not exceed the absolute maximum voltage of 40 V on V_{out}).
7. Turn on the controller / PWM input source and probe switching node to see switching operation.
8. Once operational, adjust the bus voltage and load PWM control within the operating range and observe the output switching behavior, efficiency and other parameters.
9. For shutdown, please follow steps in reverse.

NOTE. When measuring the high frequency content switch node (OUT), care must be taken to avoid long ground leads. Measure the switch node (OUT) by placing the oscilloscope probe tip through the large via on the switch node (designed for this purpose) and grounding the probe directly across the GND terminals provided. See Figure 3 for proper scope probe technique.

THERMAL CONSIDERATIONS

The EPC9001 development board showcases the EPC2015 *eGaN FET*. Although the electrical performance surpasses that for traditional Si devices, their relatively smaller size does magnify the thermal management requirements. The EPC9001 is intended for bench evaluation with low ambient temperature and convection cooling. The addition of heat-sinking and forced air cooling can significantly increase the current rating of these devices, but care must be taken to not exceed the absolute maximum die temperature of 125°C.

NOTE. The EPC9001 development board does not have any current or thermal protection on board.

Table 2 : Bill of Material

Item	Qty	Reference	Part Description	Manufacturer / Part #
1	4	C4, C10, C11, C13	Capacitor, 1uF, 10%, 25V, X5R	Murata, GRM188R61E105KA12D
2	2	C6, C7	Capacitor, 100pF, 5%, 50V, NP0	TDK, C1608C0G1H101J
3	1	C12	Capacitor, 0.1uF, 10%, 25V, X5R	TDK, C1608X5R1E104K
4	2	C16, C17	Capacitor, 4.7uF, 20%, 50V, X5R	Taiyo Yuden, UMK325BJ475M
5	2	D1, D2	Schottky Diode, 30V	Diodes Inc., SDM03U40-7
6	3	J1, J2, J9	Connector	2pins of Tyco, 4-103185-0
7	1	J3, J4, J5, J6, J7, J8	Connector	FCI, 68602-224HLF
8	2	Q1, Q2	eGaN® FET	EPC, EPC2015
9	1	R1	Resistor, 10.0K, 5%, 1/8W	Stackpole, RMCF0603FT10K0
10	2	R2, R15	Resistor, 0 Ohm, 1/8W	Stackpole, RMCF0603ZT0R00
11	1	R4	Resistor, 22 Ohm, 1%, 1/8W	Stackpole, RMCF0603FT22R0
12	1	R5	Resistor, 47 Ohm, 1%, 1/8W	Stackpole, RMCF0603FT47R0
13	2	R11, R12	Resistor, 0 Ohm, 1/8W	Stackpole, RMCF0603ZT0R00
14	2	TP1, TP2	Test Point	Keystone Elect, 5015
15	1	TP3	Connector	1/40th of Tyco, 4-103185-0
16	1	U1	I.C., Logic	Fairchild, NC7SZ00L6X
17	1	U2	I.C., Gate driver	Texas Instruments, LM5113
18	1	U3	I.C., Regulator	Microchip, MCP1703T-5002E/MC
19	1	U4	I.C., Logic	Fairchild, NC7SZ08L6X
20	0	R13, R14	Optional Resistor	
21	0	C15, C19	Optional Capacitor	
22	0	D5, D6	Optional Diode	
23	0	P1, P2	Optional Potentiometer	

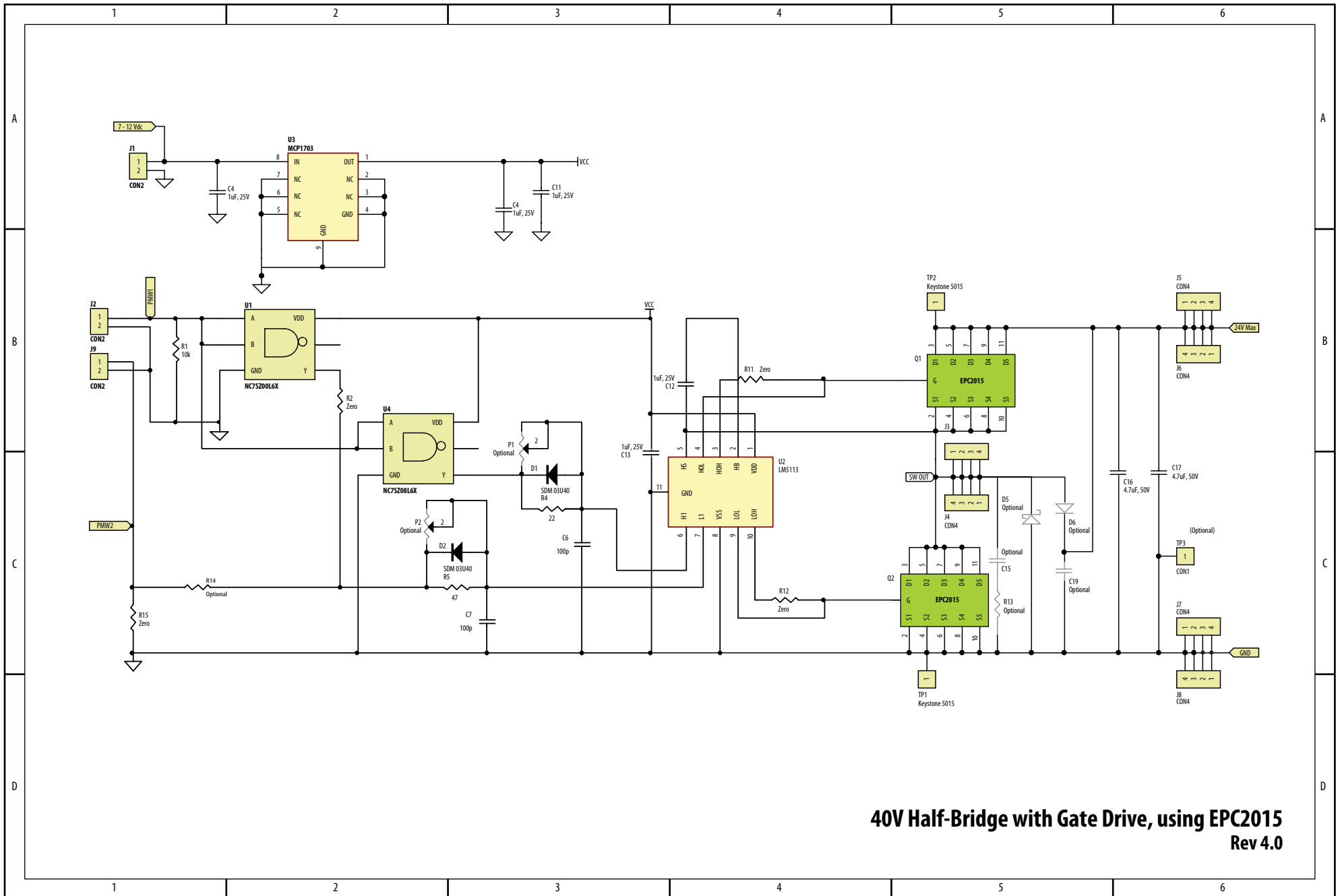

40V Half-Bridge with Gate Drive, using EPC2015
Rev 4.0

Contact us:

www.epc-co.com

Renee Yawger

WW Marketing

Office: +1.908.475.5702

Mobile: +1.908.619.9678

renee.yawger@epc-co.com

Stephen Tsang

Sales, Asia

Mobile: +852.9408.8351

stephen.tsang@epc-co.com

Bhasy Nair

Global FAE Support

Office: +1.972.805.8585

Mobile: +1.469.879.2424

bhasy.nair@epc-co.com

Peter Cheng

FAE Support, Asia

Mobile: +886.938.009.706

peter.cheng@epc-co.com



EPC Products are distributed exclusively through Digi-Key.

www.digikey.com

Development Board / Demonstration Board Notification

The EPC9001 board is intended for product evaluation purposes only and is not intended for commercial use. As an evaluation tool, it is not designed for compliance with the European Union directive on electromagnetic compatibility or any other such directives or regulations.

As board builds are at times subject to product availability, it is possible that boards may contain components or assembly materials that are not RoHS compliant. Efficient Power Conversion Corporation (EPC) makes no guarantee that the purchased board is 100% RoHS compliant.

No Licenses are implied or granted under any patent right or other intellectual property whatsoever. EPC assumes no liability for applications assistance, customer product design, software performance, or infringement of patents or any other intellectual property rights of any kind.

EPC reserves the right at any time, without notice, to change said circuitry and specifications.