

NOTES:

- 1) MATERIALS:  
HOUSING: GLASS FILLED POLYESTER, UL94 V-0, COLOR: BLACK  
TERMINALS: PHOSPHOR BRONZE
- 2) FINISH:  
TERMINALS:  
(A) SELECT GOLD IN CONTACT AREA: 50 MICROINCHES (1.27 MICROMETERS) MIN.,  
\*SELECT TIN IN PC TAIL AREA: 100 MICROINCHES (2.54 MICROMETERS) MIN.,  
WITH OVERALL NICKEL UNDERPLATE: 50 MICROINCHES (1.27 MICROMETERS) MIN.  
(B) SELECT GOLD IN CONTACT AREA: 30 MICROINCHES (0.76 MICROMETERS) MIN.,  
\*SELECT TIN IN PC TAIL AREA: 100 MICROINCHES (2.54 MICROMETERS) MIN.,  
WITH OVERALL NICKEL UNDERPLATE: 50 MICROINCHES (1.27 MICROMETERS) MIN.  
\*THE PRIMARY SHIPPING CARTON WILL BE LABELED "COMPLIANT TO RoHS"  
DIRECTIVE 2002/95/EC AND ELV ANNEX II OF DIRECTIVE 2000/53/EC,"  
CARTONS WITHOUT THIS LABEL MAY CONTAIN PRODUCT WITH TIN-LEAD  
IN THE PC TAIL AREA.
- 3) ALL JACKS MUST MEET THE REQUIREMENTS OF MOLEX SPECIFICATION #PS-41314.
- 4) PACKAGING: THERMOFORMED TRAYS PER PK-41369-004.
- 5) JACKS CONFORM TO AND ACCEPT PLUGS WHICH CONFORM TO FCC REGULATIONS, PART 68.5.
- 6) JACKS ARE TO BE USED WITH .062/(1.57) THICK PRINTED CIRCUIT BOARDS.
- 7) SEE SHEET 3 FOR RECOMMENDED PANEL CUT-OUT AND BOARD LAYOUT DIMENSIONS.
- 8) ALL UNTOLERANCED DIMENSIONS ARE SHOWN FOR REFERENCE ONLY.

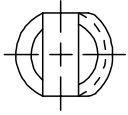
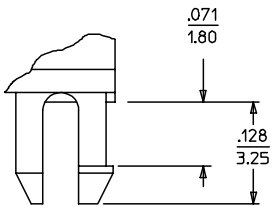
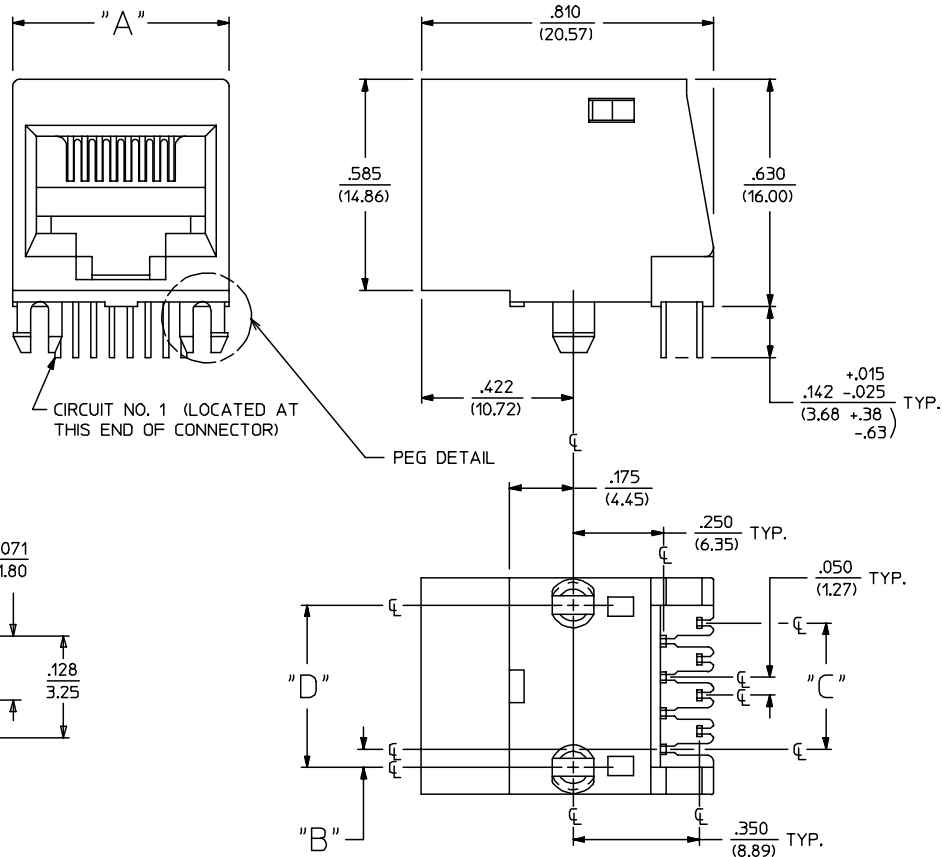

PEG DETAIL  
SCALE: 8:1

SIZE 8 MODULAR JACK HOUSING LOADED WITH 8 TERMINALS IS SHOWN ABOVE



8	2	.600 (15.24)	.200 (5.08)	.050 (1.27)	.450 (11.43)
8	4	.600 (15.24)	.150 (3.81)	.150 (3.81)	.450 (11.43)
8	6	.600 (15.24)	.100 (2.54)	.250 (6.35)	.450 (11.43)
8	8	.600 (15.24)	.050 (1.27)	.350 (8.89)	.450 (11.43)
6	2	.520 (13.21)	.175 (4.45)	.050 (1.27)	.400 (10.16)
6	4	.520 (13.21)	.125 (3.18)	.150 (3.81)	.400 (10.16)
6	6	.520 (13.21)	.075 (1.91)	.250 (6.35)	.400 (10.16)
4	2	.440 (11.18)	.125 (3.18)	.050 (1.27)	.300 (7.62)
4	4	.440 (11.18)	.075 (1.91)	.150 (3.81)	.300 (7.62)
HOUSING SIZE	CIRCUIT SIZE	DIM. "A"	DIM. "B"	DIM. "C"	DIM. "D"

3	R
2	R1
1	R1
SH	REV

2006/06/27 REMOVE FILM/ARMO/PAKER FC NO: UCP2006-2453 DRWN:PRIDDER 2006/06/14 CHKD:JBELL APPR:FSMITH R1	QUALITY SYMBOLS -0 -0	GENERAL TOLERANCES (UNLESS SPECIFIED) DIMENSION STYLE mm INCH 4 PLACES ± --- ± --- 3 PLACES ± --- ± --- 2 PLACES ± --- ± --- 1 PLACE ± --- ± --- ANGULAR ±1/2° DRAFT WHERE APPLICABLE MUST REMAIN WITHIN DIMENSIONS	SCALE 4:1 DESIGN UNITS INCH DIMENSION STYLE IN/MM DRAWN BY DATE GLT 1990/05/16 CHECKED BY DATE BAP 1990/05/16 APPROVED BY DATE RAS 1990/05/16	THIRD ANGLE PROJECTION REVISE ON CAD ONLY TITLE RIGHT ANGLE FLANGELESS MODULAR JACK ASSEMBLY MOLEX MOLEX INCORPORATED MATERIAL NO. DOCUMENT NO. SEE SHEET 2 SDA-41687-***** SHEET NO. 1 OF 3
	THIS DRAWING CONTAINS INFORMATION THAT IS PROPRIETARY TO MOLEX INCORPORATED AND SHOULD NOT BE USED WITHOUT WRITTEN PERMISSION			
	THIS DRAWING CONTAINS INFORMATION THAT IS PROPRIETARY TO MOLEX INCORPORATED AND SHOULD NOT BE USED WITHOUT WRITTEN PERMISSION			
	THIS DRAWING CONTAINS INFORMATION THAT IS PROPRIETARY TO MOLEX INCORPORATED AND SHOULD NOT BE USED WITHOUT WRITTEN PERMISSION			

ENGINEERING PART NUMBER	E.D.P. NUMBER	HOUSING SIZE	CIRCUIT SIZE	PLATING OPTION	PACKAGING OPTION
A-41687-44ABAA	015-43-8544	4	4	A	TRAY PACK
A-41687-42ABAA	015-43-8541	4	2	A	TRAY PACK
A-41687-66ABAA	015-43-8566	6	6	A	TRAY PACK
A-41687-64ABAA	015-43-8564	6	4	A	TRAY PACK
A-41687-62ABAA	015-43-8561	6	2	A	TRAY PACK
A-41687-88ABAA	015-43-8588	8	8	A	TRAY PACK
A-41687-88BBAA	015-43-8589	8	8	B	TRAY PACK
A-41687-86ABAA	015-43-8586	8	6	A	TRAY PACK
A-41687-84ABAA	015-43-8584	8	4	A	TRAY PACK
A-41687-82ABAA	015-43-8590	8	2	A	TRAY PACK

SEE SHEET 1 FOR PART DESCRIPTIONS

SEE SHEET ONE EC NO: UCP2006-2453 DRWN:PRIDDER 2006/06/14 CHKD:JBELL 2006/06/27 APPR:FSMITH 2006/06/29 R1	QUALITY SYMBOLS	GENERAL TOLERANCES (UNLESS SPECIFIED)	SCALE ---	DESIGN UNITS INCH	THIRD ANGLE PROJECTION	REVISE ON CAD ONLY															
	 -0  -0	<table border="1"> <thead> <tr> <th></th> <th>mm</th> <th>INCH</th> </tr> </thead> <tbody> <tr> <td>4 PLACES</td> <td>± ---</td> <td>± ---</td> </tr> <tr> <td>3 PLACES</td> <td>± ---</td> <td>± ---</td> </tr> <tr> <td>2 PLACES</td> <td>± ---</td> <td>± ---</td> </tr> <tr> <td>1 PLACE</td> <td>± ---</td> <td>± ---</td> </tr> </tbody> </table>		mm	INCH	4 PLACES	± ---	± ---	3 PLACES	± ---	± ---	2 PLACES	± ---	± ---	1 PLACE	± ---	± ---	DIMENSION STYLE IN/MM DRAWN BY GLT DATE 1990/05/16 CHECKED BY BAP DATE 1990/05/16 APPROVED BY RAS DATE 1990/05/16	TITLE RIGHT ANGLE FLANGELESS MODULAR JACK ASSEMBLY	MOLEX INCORPORATED MATERIAL NO. SEE CHART DOCUMENT NO. SDA-41687-***** SHEET NO. 2 OF 3	
		mm	INCH																		
	4 PLACES	± ---	± ---																		
3 PLACES	± ---	± ---																			
2 PLACES	± ---	± ---																			
1 PLACE	± ---	± ---																			
DRAFT WHERE APPLICABLE MUST REMAIN WITHIN DIMENSIONS		THIS DRAWING CONTAINS INFORMATION THAT IS PROPRIETARY TO MOLEX INCORPORATED AND SHOULD NOT BE USED WITHOUT WRITTEN PERMISSION																			
THIS DRAWING CONTAINS INFORMATION THAT IS PROPRIETARY TO MOLEX INCORPORATED AND SHOULD NOT BE USED WITHOUT WRITTEN PERMISSION																					

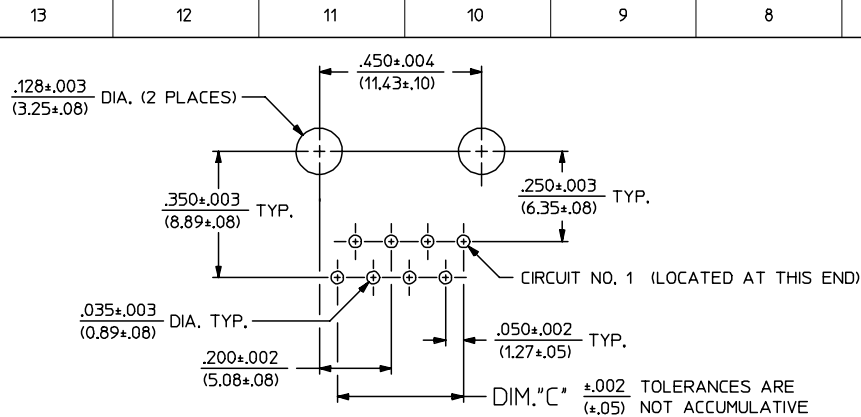

PC BOARD LAYOUT FOR HOUSING SIZE 8

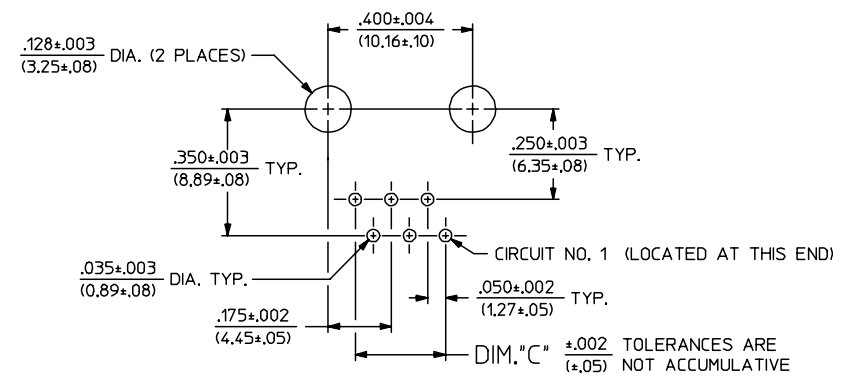

PC BOARD LAYOUT FOR HOUSING SIZE 6

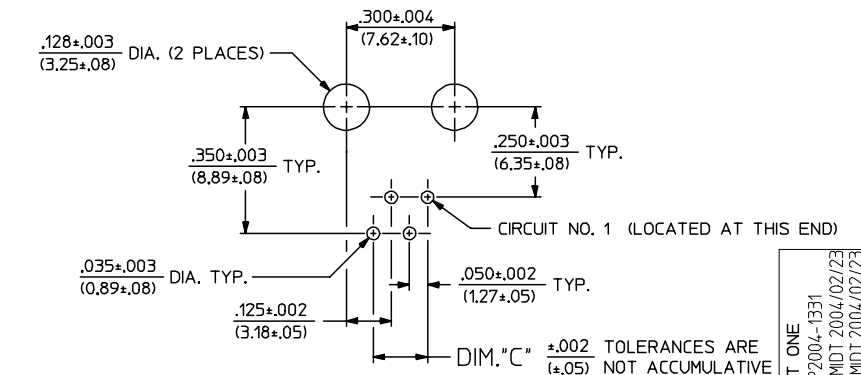

PC BOARD LAYOUT FOR HOUSING SIZE 4

ENGINEERING PART NUMBER	HOUSING SIZE	CIRCUIT SIZE	DIM. "A"	DIM. "B"	DIM. "C"
A-41687-44XXXX	4	4	.455/(11.56)	.300/(7.62)	.150/(3.81)
A-41687-42XXXX	4	2	.455/(11.56)	.300/(7.62)	.050/(1.27)
A-41687-66XXXX	6	6	.535/(13.59)	.400/(10.16)	.250/(6.35)
A-41687-64XXXX	6	4	.535/(13.59)	.400/(10.16)	.150/(3.81)
A-41687-62XXXX	6	2	.535/(13.59)	.400/(10.16)	.050/(1.27)
A-41687-88XXXX	8	8	.615/(15.62)	.450/(11.43)	.350/(8.89)
A-41687-86XXXX	8	6	.615/(15.62)	.450/(11.43)	.250/(6.35)
A-41687-84XXXX	8	4	.615/(15.62)	.450/(11.43)	.150/(3.81)
A-41687-82XXXX	8	2	.615/(15.62)	.450/(11.43)	.050/(1.27)

NOTE: ALL RECOMMENDED BOARD LAYOUTS ARE SHOWN AS COMPONENT SIDE OF BOARD

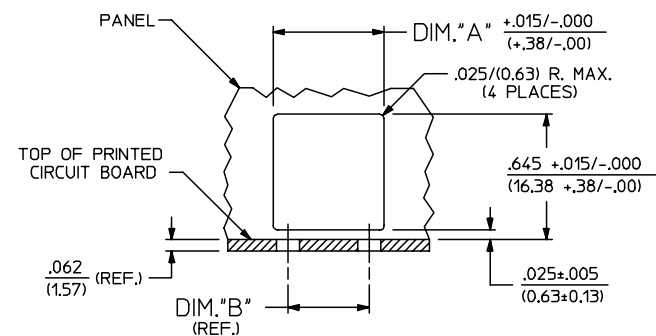

PANEL CUT-OUT GUIDELINES

DIM. "A" MUST BE SYMMETRICAL TO DIM. "B" WITHIN .005/(0.13)

SEE SHEET ONE EC NO: UCP2004-1331 DRW: LSCHEMIDT 2004/02/23 CHKD: LSCHEMIDT 2004/02/23 APPR: FSMITH - 2004/02/26	QUALITY SYMBOLS	GENERAL TOLERANCES (UNLESS SPECIFIED)	SCALE --- INCH	DESIGN UNITS INCH	THIRD ANGLE PROJECTION	REVISE ON CAD ONLY
	▽ = 0 ▽ = 0	mm INCH 4 PLACES ± --- ± --- 3 PLACES ± --- ± --- 2 PLACES ± --- ± --- 1 PLACE ± --- ± --- ANGULAR ±1/2°	DIMENSION STYLE IN/MM DRAWN BY DATE GLT 1990/05/16 CHECKED BY DATE BAP 1990/05/16 APPROVED BY DATE RAS 1990/05/16	TITLE PANEL/BOARD LAYOUTS FOR RIGHT ANGLE FLANGELESS MODULAR JACK ASSEMBLIES MOLEX MOLEX INCORPORATED MATERIAL NO. DOCUMENT NO. SHEET NO. SEE SHEET 2 SDA-41687-***** 3 OF 3		
DRAFT WHERE APPLICABLE MUST REMAIN WITHIN DIMENSIONS		THIS DRAWING CONTAINS INFORMATION THAT IS PROPRIETARY TO MOLEX INCORPORATED AND SHOULD NOT BE USED WITHOUT WRITTEN PERMISSION				