

73631-30** SERIES

GENERAL NOTES:

- 68 CIRCUIT SHOWN FOR ILLUSTRATION PURPOSES ONLY.
- SEE SHEET 2 FOR ITEM NO'S, CHARTED DIMENSIONS, PACKAGING, MATERIAL SPEC'S AND P.C. BOARD LAYOUT FOR SERIES 73631-30**.
- TAIL PATTERN FIXED AT CIRCUIT NO. (1) POSITION FOR ALL CIRCUIT SIZES LISTED IN CHARTS FOR ALL SERIES.
- FOR SERIES 73631-31** REFER TO SHEETS 3 AND 4.

ADD LEADFREE NOTE EC NO. UCP2004-1925 DRW:DMORGAN 04/04/05 CHK: BBARKER 04/04/05 APPR:SMILLER 04/04/05	QUALITY SYMBOLS	GENERAL TOLERANCES: (UNLESS SPECIFIED)	SCALE 4 : 1	DESIGN UNITS <input type="checkbox"/> mm <input checked="" type="checkbox"/> INCH	THIRD ANGLE PROJECTION <input checked="" type="checkbox"/> <input type="checkbox"/> mm ONLY <input type="checkbox"/> INCH ONLY	TITLE: SALES SCSI ALL-PLASTIC VERTICAL RECEPTACLE ASS'Y W/LATCHES & POLZTN PEG	SHT 4	REV F
	MAJOR $\nabla = 0$	4 PLACES $\pm 0.$ $\pm .$	mm	INCH	DRAWN BY & DATE <i>J. Long</i> 96/11/13	MATERIAL NO. SEE SH'T 2 DRAWING NO. SD-73631-006	SHEET NO. 1 OF 4	REVISE ON CAD ONLY
	CRITICAL $\nabla C = 0$	3 PLACES $\pm 0.$ $\pm .005$			CHECKED BY & DATE <i>J. Long</i> 96/11/14			
		2 PLACES ± 0.013 $\pm .$			APPROVED BY & DATE BRINKMAN 96/11/15	MOLEX INCORPORATED		
	1 PLACE $\pm 0.$ $\pm .$	ANGULAR: $\pm 1/2^\circ$	CAD FILENAME S7363131.DGN		THIS DRAWING CONTAINS INFORMATION THAT IS PROPRIETARY TO MOLEX INCORPORATED AND SHOULD NOT BE USED WITHOUT WRITTEN PERMISSION.			SIZE C

MATERIAL NO.	CIRCUIT SIZE	DIM. A		DIM. B		DIM. D		DIM. P		RECOMMENDED PCB	
		INCH	MM	INCH	MM	INCH	MM	INCH	MM	INCH	MM
73631-3001	50	1.665	42.29	1.200	30.48	1.366	34.70	.125	3.18	.062 OR .093	1.57 OR 2.36
73631-3002	68	2.115	53.72	1.650	41.91	1.816	46.13	.125	3.18	.062 OR .093	1.57 OR 2.36

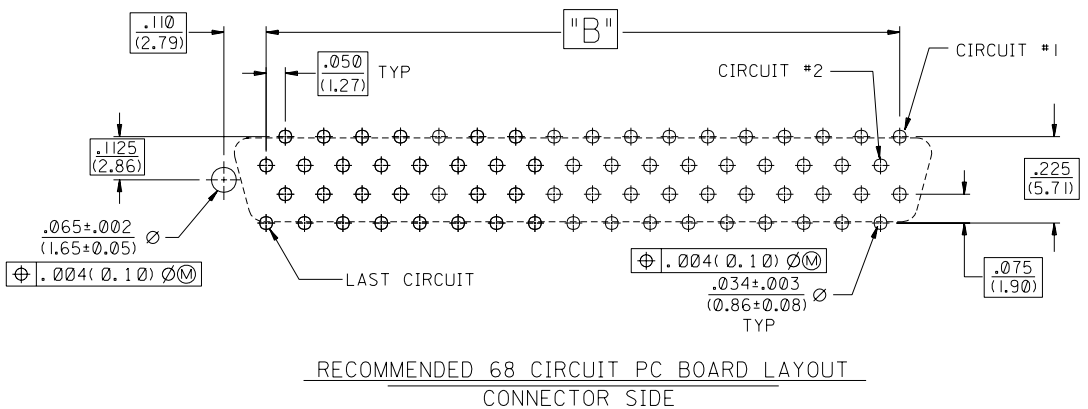
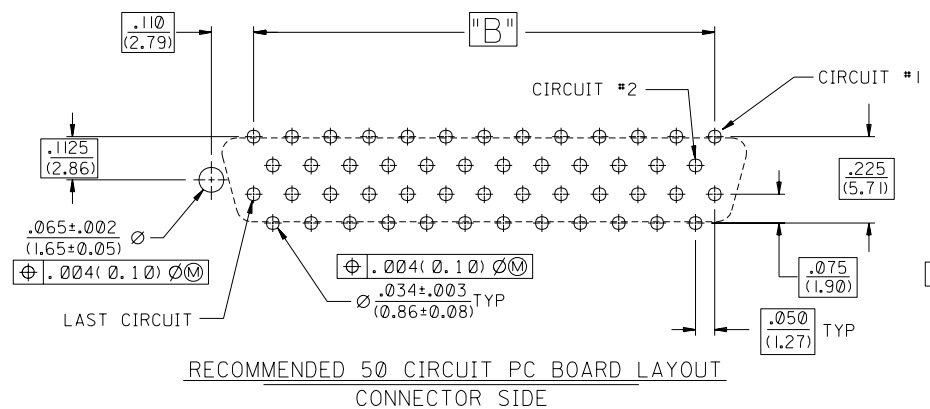

NOTES:

1. MATERIAL:
RECEPTACLE HOUSING: GLASS FILLED LIQUID CRYSTAL POLYMER;
COLOR: BLACK; UL 94V-0
TERMINALS: PHOSPHOR BRONZE
2. FINISH:
TERMINALS: SEE LIST BELOW
3. REFER TO PS-79058 PRODUCT SPEC. FOR ELECTRICAL,
MECHANICAL AND ENVIRONMENTAL SPECIFICATIONS.
4. PACKAGING:
PARTS PACKAGED IN TUBES PER PK-70873-0427.

TERMINAL FINISH:

SELECTIVE GOLD: THICKNESS= 30 MICROINCHES/(0.76 MICROMETERS) MINIMUM.
SELECTIVE TIN: THICKNESS= 75 MICROINCHES/(1.90 MICROMETERS) MINIMUM.
NICKEL UNDERPLATE OVERALL.

NOTE FOR LEAD FREE CONVERSION:
THE PRIMARY SHIPPING CARTON WILL BE
LABELED "COMPLIANT TO ROHS DIRECTIVE
2002/95/EC AND ELV ANNEX II OF
DIRECTIVE 2000/53/EC". CARTONS
WITHOUT THIS LABEL MAY CONTAIN
PRODUCT WITH LEAD.

73631-30** SERIES

ADD LEADFREE NOTE EC No. LUCP2004-1925 DRAWN: DMORGAN 04/04/05 CHK: BBARKER 04/04/05 APPR: SWILLER 04/04/05	MAJOR QUALITY SYMBOLS CRITICAL	GENERAL TOLERANCES: (UNLESS SPECIFIED)		SCALE 4:1	DESIGN UNITS <input type="checkbox"/> mm <input checked="" type="checkbox"/> INCH	DIMENSIONS: <input type="checkbox"/> mm <input checked="" type="checkbox"/> INCH <input type="checkbox"/> mm ONLY	SHT	REV
		4 PLACES ±0.	±.	DRAWN BY & DATE <i>J. Long</i> 96/11/13		TITLE: SALES SCSI ALL-PLASTIC VERTICAL RECEPTACLE ASS'Y W/LATCHES & POLZTN PEG		
		3 PLACES ±0.	±.005	CHECKED BY & DATE <i>J. Long</i> 96/11/14		MATERIAL NO. SEE CHART		
		2 PLACES ±0.13	±.	APPROVED BY & DATE BRINKMAN 96/11/15		DRAWING NO. SD-73631-006		
1 PLACE ±0.	±.	ANGULAR: ± 1/2°		CAD FILENAME S7363132.DGN	MATERIAL NO. SEE CHART	DRAWING NO. SD-73631-006	SHEET NO. 2	
REV	DESCRIPTION	DRAFT WHERE APPLICABLE MUST REMAIN WITHIN DIMENSIONS		THIS DRAWING CONTAINS INFORMATION THAT IS PROPRIETARY TO MOLEX INCORPORATED AND SHOULD NOT BE USED WITHOUT WRITTEN PERMISSION.				SIZE C