

THIS DRAWING IS UNPUBLISHED. RELEASED FOR PUBLICATION
 (C) COPYRIGHT 19 BY AMP INCORPORATED. ALL RIGHTS RESERVED.

REV. NO.		REVISIONS			DATE	DWN	APVD
P	LTR	DESCRIPTION					
CM	53	D	REV PER EC	061B-0127-98	6-24-98	BL	RS

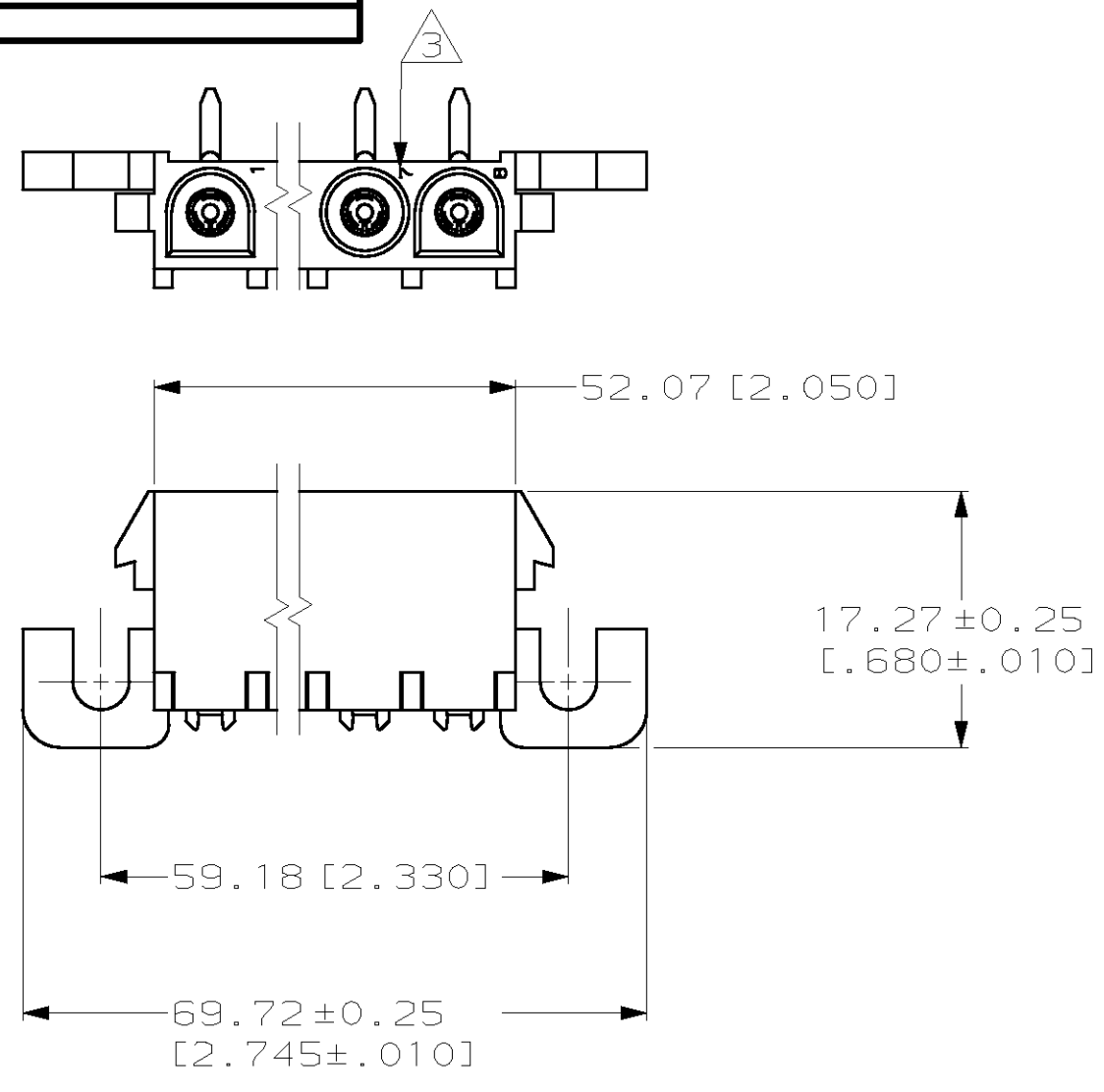

- PARTS MUST COMPLY WITH AMP SOLDERABILITY SPEC 109-11-5.
- TOLERANCE NON-CUMULATIVE.
- CIRCUIT IDENTIFICATION CHARACTERS ARE ADJACENT TO THE INDICATED CAVITIES, BUT LOCATION AND ORIENTATION MAY DIFFER FROM PRINT.

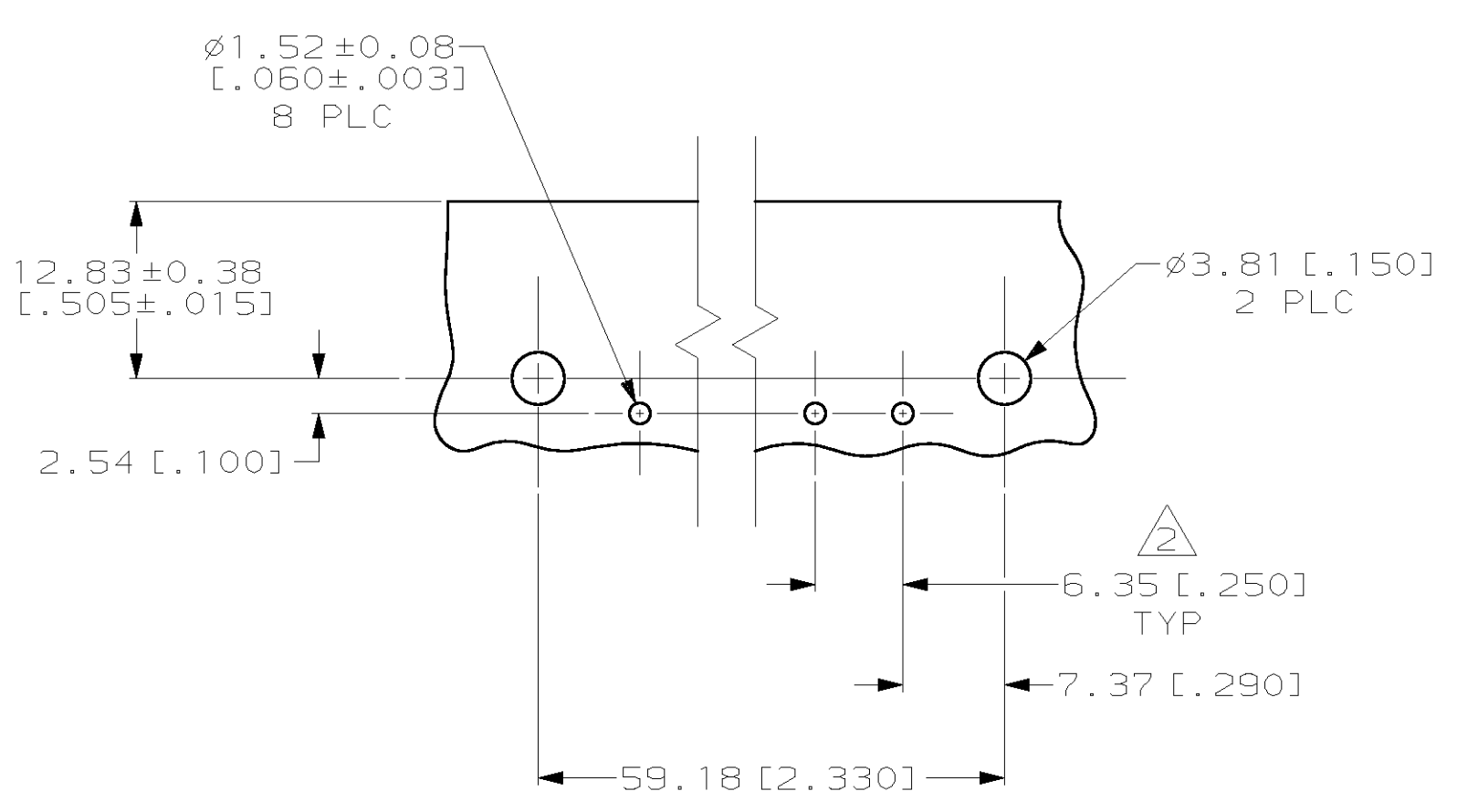
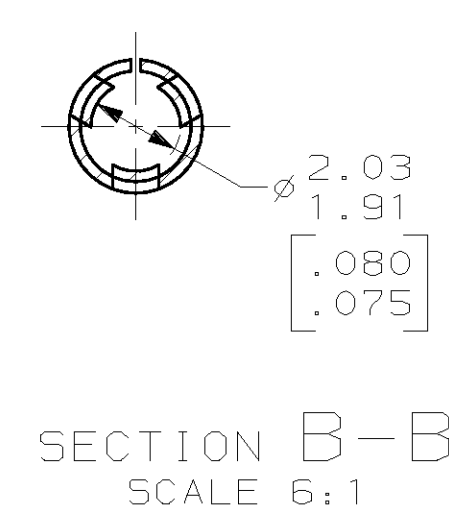
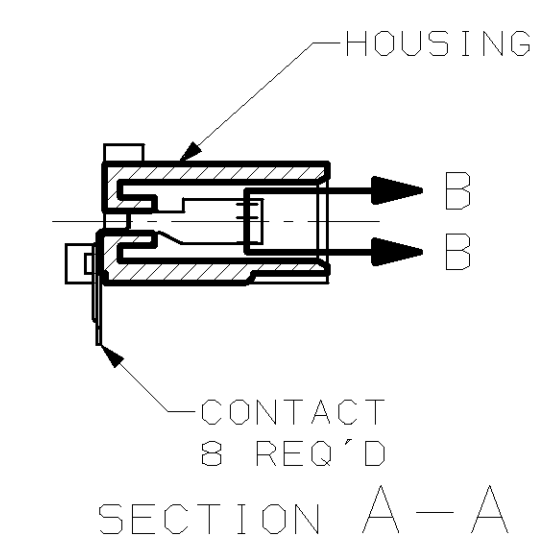
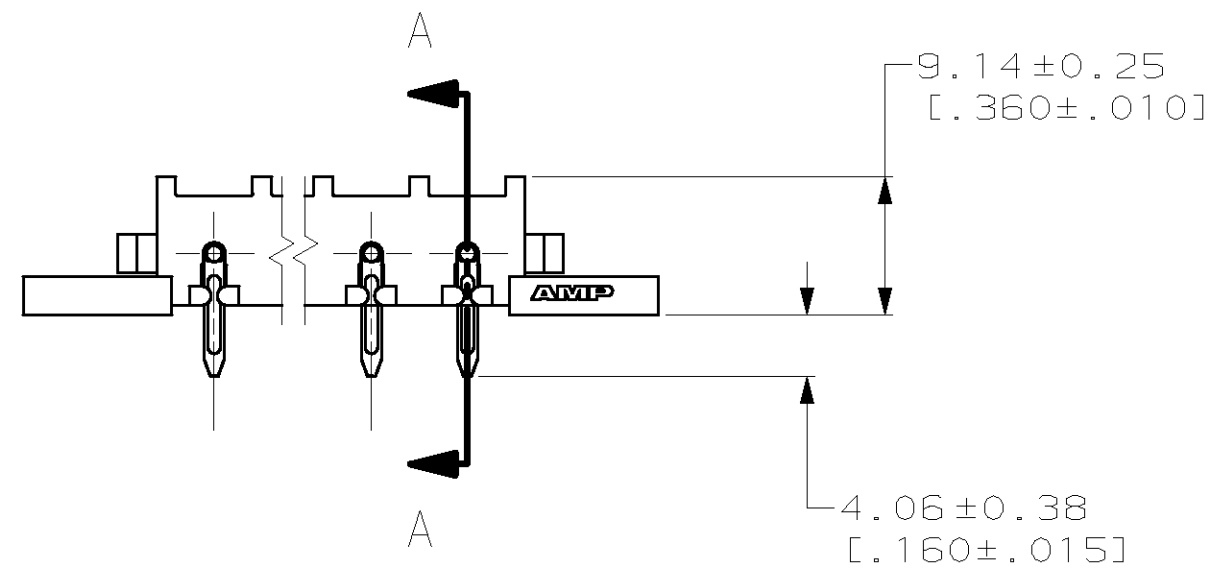

RECOMMENDED MOUNTING HOLE PATTERN FOR 1.57 [.062] THICK P.C. BOARD

METRIC

PHOS BRZ PRE-TIN	NYLON, UL94V-2	643237-1
CONTACT	HOUSING	PART NO

<small>THIS DRAWING IS A CONTROLLED DOCUMENT FOR AMP INCORPORATED. IT IS SUBJECT TO CHANGE AND THE CONTROLLING ENGINEERING ORGANIZATION SHOULD BE CONTACTED FOR THE LATEST REVISION.</small>		DWN R. VESTAL 7-19-95 CHK R. SWING 7-19-95 APVD D. SELF 7-19-95	AMP AMP Incorporated Harrisburg, PA 17105-3608
DIMENSIONS: mm [INCHES] 		NAME SOCKET HEADER ASSEMBLY, RIGHT ANGLE MOUNT, 8 POSITION, UNIVERSAL MATE-N-LOK™	
TOLERANCES UNLESS OTHERWISE SPECIFIED: 0 PLC ±- 1 PLC ±- 2 PLC ±0.13 [.005] 3 PLC ±- 4 PLC ±- ANGLES ±0°30' FINISH SEE TABLE		PRODUCT SPEC - APPLICATION SPEC - WEIGHT -	SIZE A2 CAGE CODE 00779 DRAWING NO C-643237
MATERIAL SEE TABLE		CUSTOMER DRAWING	SCALE 2:1 SHEET 1 OF 1 REV D

643237