

THIS DRAWING IS UNPUBLISHED. RELEASED FOR PUBLICATION
 © COPYRIGHT - By - ALL RIGHTS RESERVED.

LOC	DIST	REVISIONS					
AF	50	P	LTR	DESCRIPTION	DATE	DWN	APVD
			U	REVISED PER ECR-12-013459	28NOV2012	KH	PD

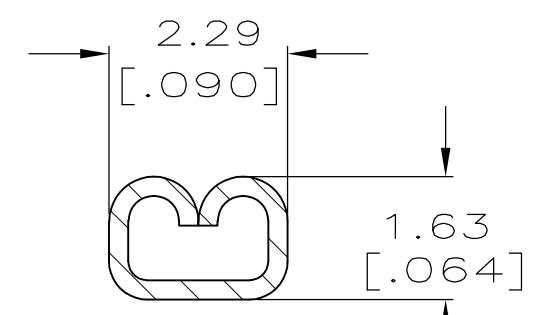

SECTION A-A
SCALE 10:1

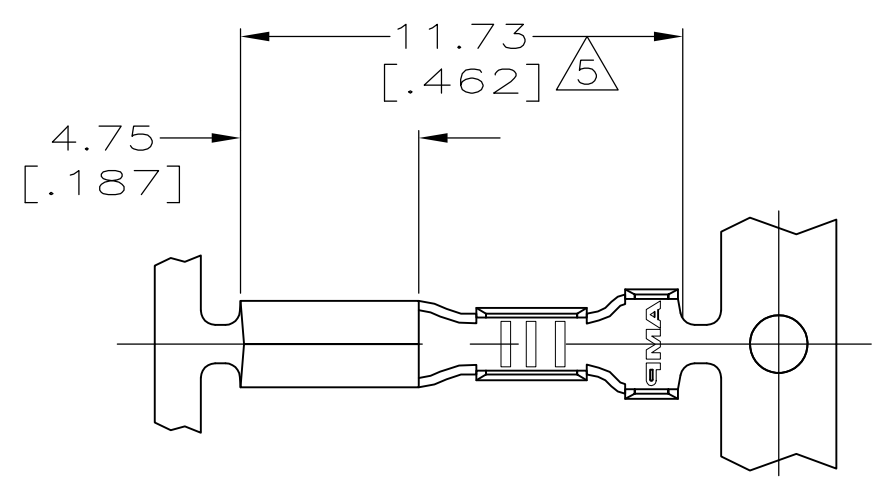
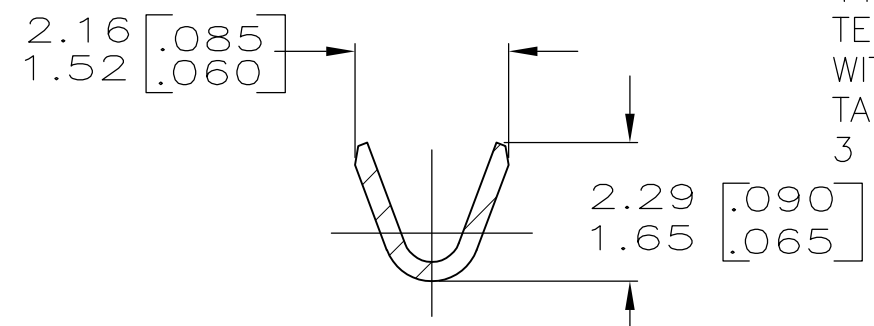
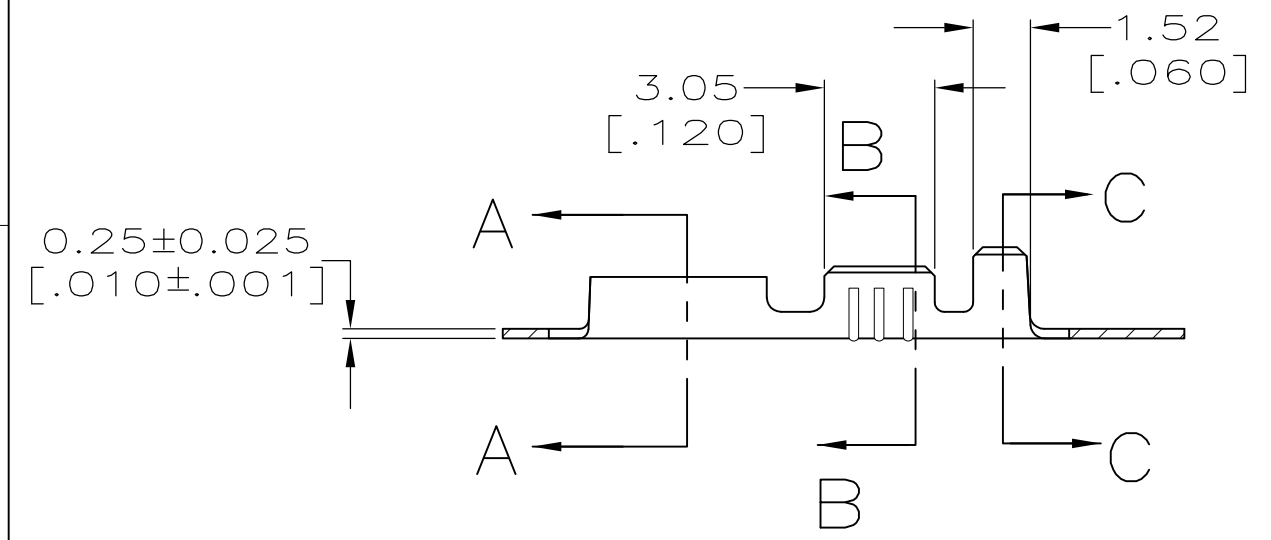

SECTION B-B
SCALE 10:1

- 1 CONTINUOUS STRIP ON REELS.
- 2 FEED IS 8.89±0.13 [.350±.005]
- △3 TIN PLATE 0.002032 [.000080] MIN.
- △4 GOLD PLATE 0.000381 [.000015] MIN OVER 0.000762 [.000030] MIN THK NICKEL.
- △5 GOLD PLATE REQUIRED IN THIS AREA ONLY.
- △6 REVERSE REELING.
- 7 MAX TEST TAB MUST ENTER & WITHDRAW FROM RECPT. WITH A MAX FORCE OF 11 LBS. (USE GAGE 100716-40). MIN TEST TAB MUST WITHDRAW FROM RECPT WITH MIN PULL OF 1 LB AFTER MAX TAB HAS BEEN INSERTED & WITHDRAWN 3 TIMES.

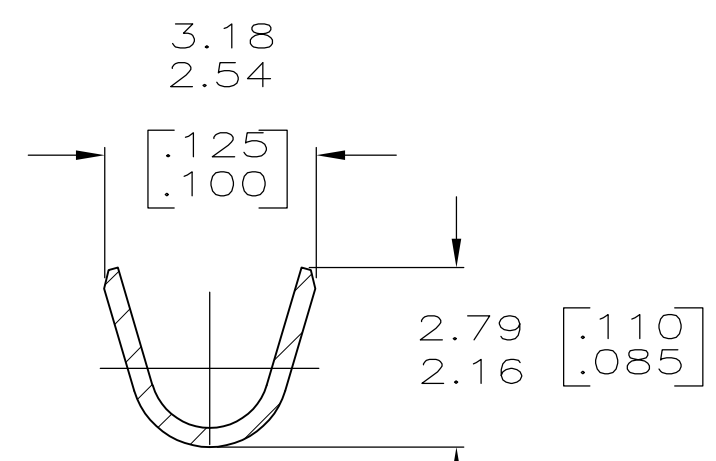

SECTION C-C
SCALE 10:1

OBSOLETE	△6	GOLD △4	1.02-2.03 DIA [.040-.080] DIA	[#24-#20] AWG	±0.025 0.79 X 1.58 ±.001 [.031 X .062]	60900-5
	△6	TIN △3				60900-4
						60900-3
		GOLD △4				60900-2
		TIN △3				60900-1
		FINISH	INSULATION RANGE	WIRE SIZE	MATING TAB THK	PART NO.

THIS DRAWING IS A CONTROLLED DOCUMENT.		DWN	JR RUTH	1/24/95	STE TE Connectivity	
		CHK	MS FEHER	1/24/95		
		APVD	R REINER	1/24/95	NAME	
DIMENSIONS: mm [INCHES]		TOLERANCES UNLESS OTHERWISE SPECIFIED:		PRODUCT SPEC		
		0 PLC	± -	APPLICATION SPEC		
		1 PLC	± -	-		
MATERIAL		FINISH		SIZE		RESTRICTED TO
BRASS		SEE TABLE		A3 00779 C-60900		-
CUSTOMER DRAWING				SCALE	5:1	SHEET
					1 OF 1	REV
						U