

LOC		DIST		REVISIONS				DATE	APPD
ZONE	LTR	DESCRIPTION	DATE	APPD					
G	14	P	F	H	REVISED PER 0720-0124-94	27JUL94	OKS	DAP	

METRIC
 DIMENSIONS LISTED IN mm [INCHES]

AMP WIRE RANGE	E13288 Listed
16-14 AWG SOLID OR STRANDED	16-14 AWG SOLID OR STRANDED
LR7189 Certified	MILITARY P/N AND CLASS
16-14 AWG SOLID OR STRANDED	NOT APPLICABLE

⚠ STAMP AMP 16-14* APPROX AS SHOWN

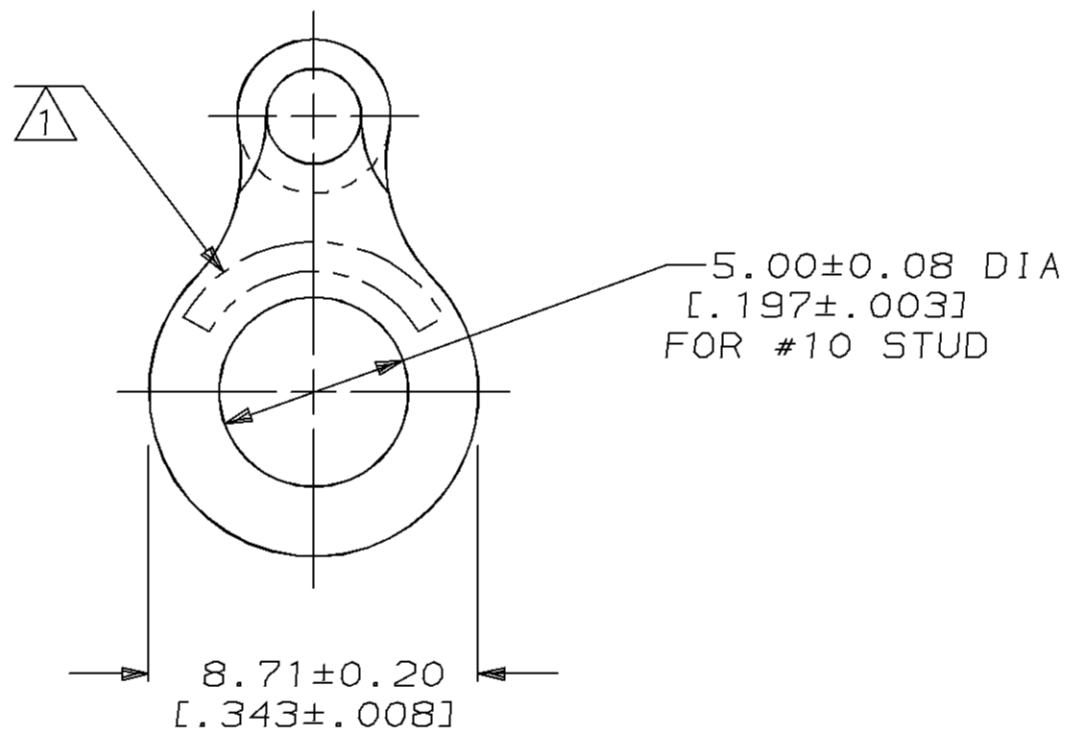
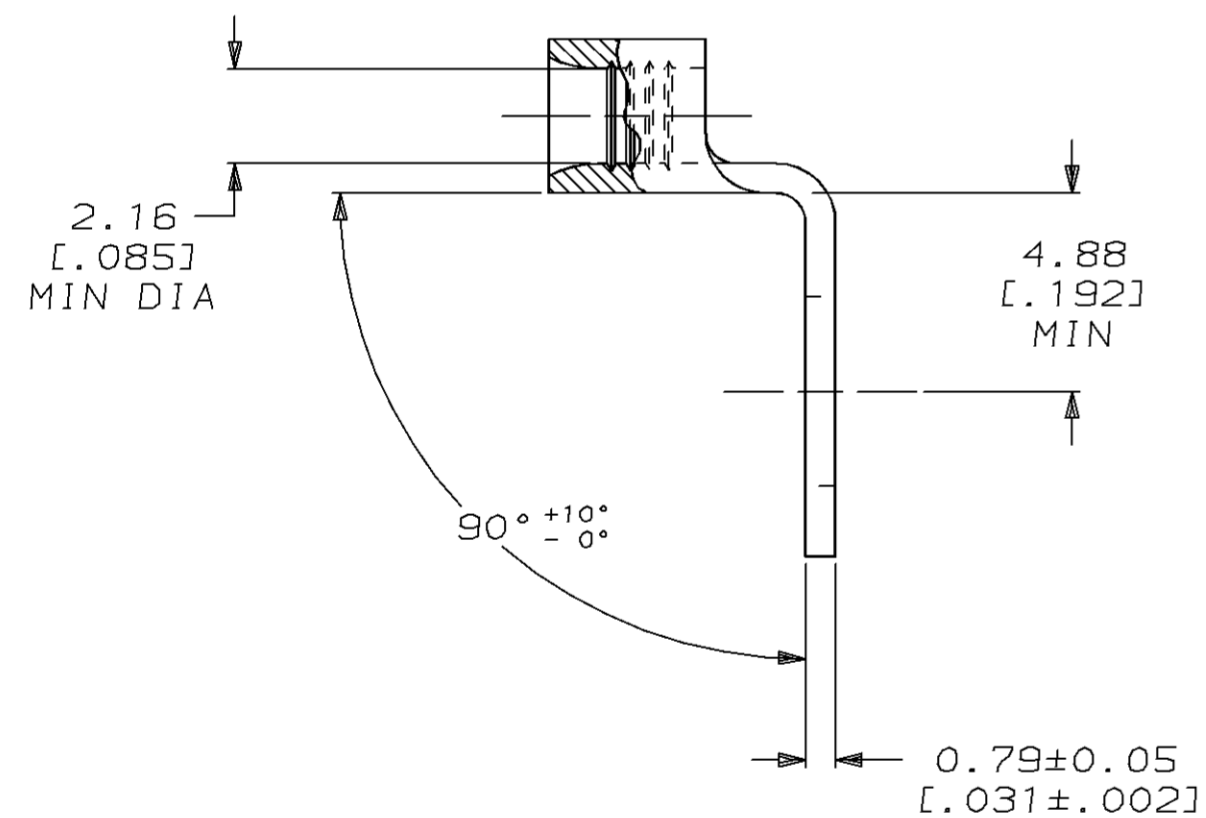
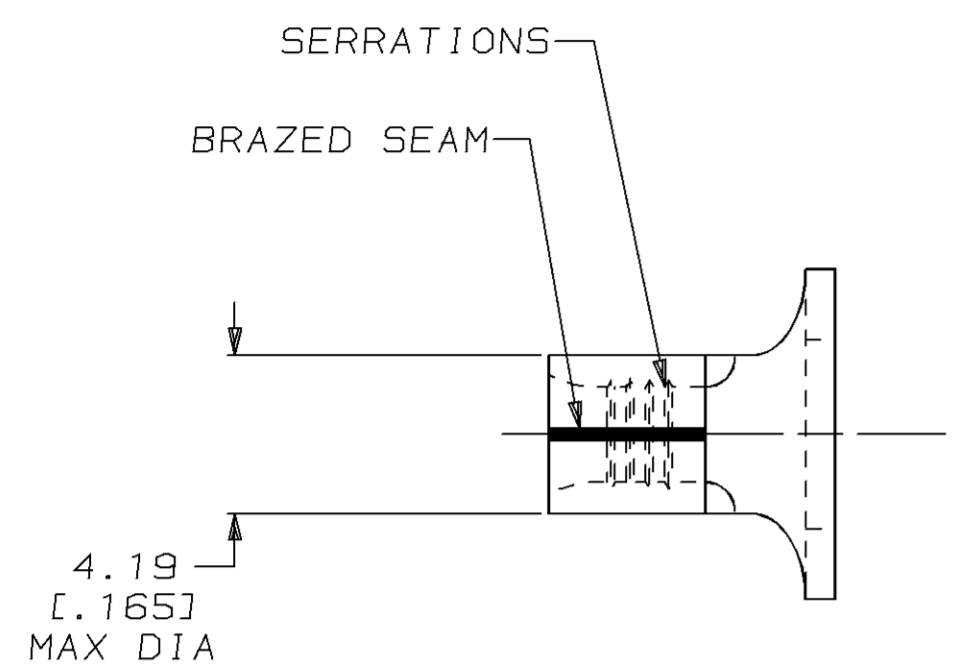

322821

B

A

AMP INCORPORATED CUSTOMER SERVICE SYSTEMS		MAX RECOMMENDED OPERATING TEMPERATURE: 170°C MAX	DO NOT SCALE PRINT. UNLESS SPECIFIED DIMENSIONS IN mm [INCHES] TOLERANCES ON: 2 PLC DEC ± 0.20 [.008] 3 PLC DEC ± - ANGLES ± -	DR 7/30/93 DK SCHRUM	322821 PART NO			
FOR ADDITIONAL PRODUCT INFORMATION OR COPIES OF DRAWINGS AND TECHNICAL DOCUMENTS	PRODUCT INFORMATION CENTER 1-800-522-6752	VOLTAGE RATING: NOT APPLICABLE	MATERIAL COPPER PER ASTM B-152 ANNEALED	CHK 8/2/93 DA PATTERSON	AMP AMP Incorporated Harrisburg, PA 17105-3608			
FOR APPLICATION TOOLING INFORMATION	TOOLING ASSISTANCE CENTER 1-800-722-1111	WIRE CROSS SECTIONAL AREA RANGE: 1.04-2.62mm ² [2,050-5,180] CIR MILS SOLID OR STRANDED	FINISH TIN PLATE 0.00254 [.000100] MIN THK PER MIL-T-10727	APPD 8/2/93 RE ROSER	NAME TERMINAL, RING TONGUE, BENT 90°, SOLISTRAND™			
FOR ORDER ENTRY	1-800-526-5142	THIS DRAWING IS A CONTROLLED DOCUMENT FOR AMP INCORPORATED. IT IS SUBJECT TO CHANGE AND THE CONTROLLING ENGINEERING ORGANIZATION SHOULD BE CONTACTED FOR THE LATEST REVISION.		APPD 8/2/93 JL MECKLEY	PRODUCT SPEC -	SIZE C	CAGE CODE 00779	DRAWING NO G=322821
AMP 1471-6 REV 3-92				APPLICATION SPEC -	WEIGHT -	SCALE 5:1		SHEET 1 OF 1

CUSTOMER DRAWING