

4

3

2

1

REVISIONS			
LTR	DESCRIPTION	DATE	APPROVED
A	OBSOLETE PER ECN T-18889 (2-7-94)	2-7-94	R.D.L.
B	REINSTATE PER ECN T-19155		

**If this document is printed it becomes uncontrolled.
Check with the web for latest revision.**

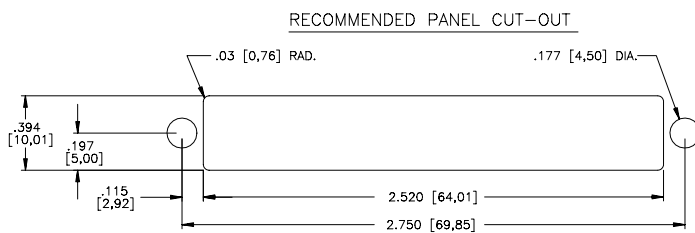
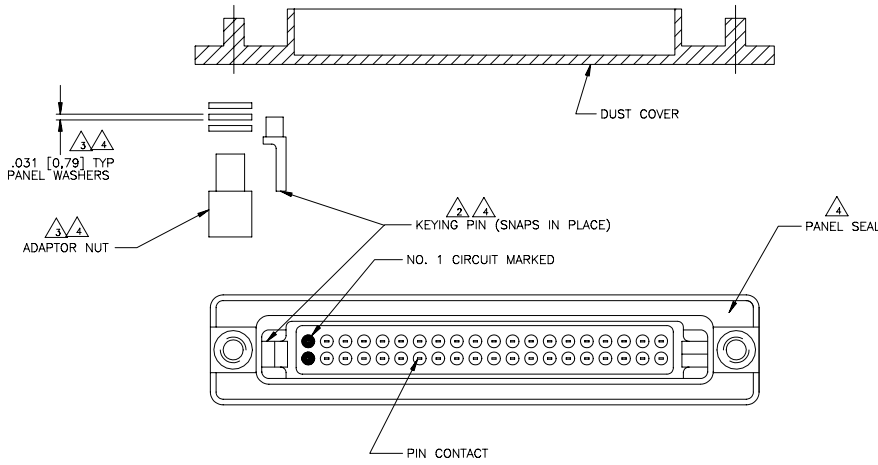
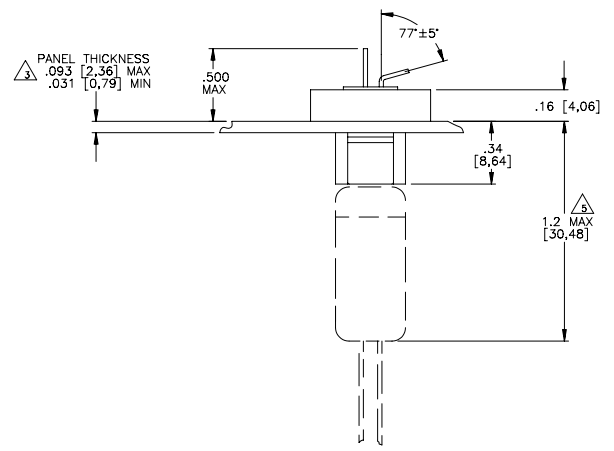
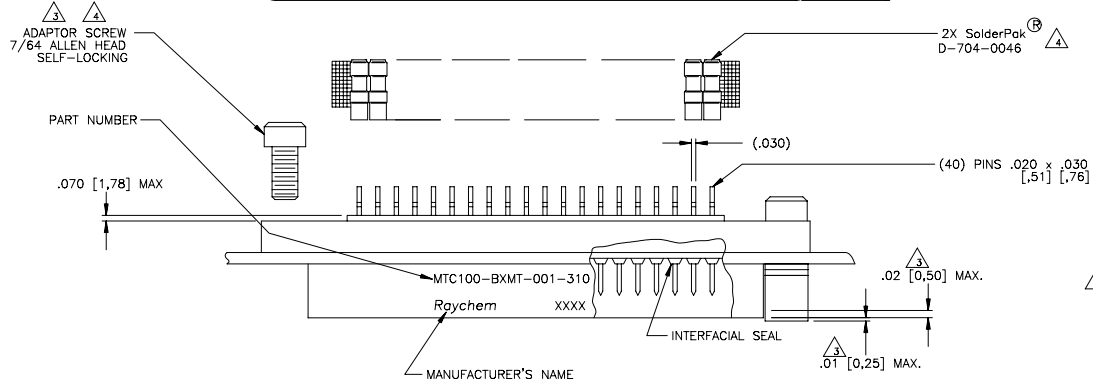
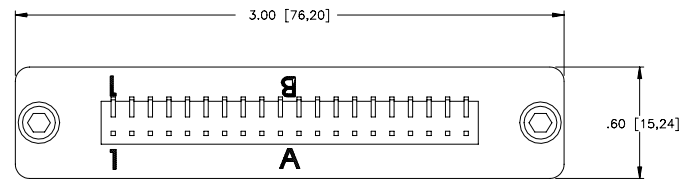

- NOTES:
- 1. BOX MOUNTED RECEPTACLE MATES WITH MTC PLUG MTC100-JH2-PXX CONTAINING SOCKET INSERTS MTC100-JXX-XXX. REFER TO RAYCHEM SPECIFICATION CONTROL DRAWING FOR DETAILS.
 - 2. FOR KEYING INFORMATION, REFER TO SHEET 2, TABLE I.
 - 3. BOX MOUNTED RECEPTACLE IS PANEL MOUNTED BY REMOVING AS MANY PANEL WASHERS AS REQUIRED TO ACCOMMODATE THE THICKNESS OF PANEL BEING USED. USE ONLY ADAPTOR SCREWS SUPPLIED. ADAPTOR NUT TO BE FLUSH TO FRONT OF PART WITHIN TOLERANCE INDICATED.
 - 4. THE FOLLOWING ITEMS ARE SUPPLIED UNASSEMBLED:

- ADAPTOR NUT (2)
- PANEL WASHER (6)
- ADAPTOR SCREW (2)
- KEYING PIN (2)
- PANEL SEAL (1)
- SolderPak (2)

5. DIMENSIONS SHOWN ARE FOR PLUG WITHOUT THE CABLE CLAMP. ADD .30 IF PLUG WITH CABLE CLAMP IS USED.

SPECIFICATION CONTROL DRAWING © Raychem Corporation 1994

UNLESS OTHERWISE SPECIFIED DIMENSIONS ARE IN INCHES. METRIC DIMENSIONS ARE IN BRACKETS.	DRAWN		2-7-94	Raychem	RAYCHEM CORPORATION 300 CONSTITUTION DRIVE MENLO PARK, CALIFORNIA 94025	
	CHECKED	D.C.P.	2-7-94		TITLE	CONNECTOR, RECEPTACLE, BOXMOUNT, 2" .020 X .030 TERMINATION POST, CAD, PLT ("B" ROW POSTS BENT 77° TO "B" SIDE) (SolderPak [®] INCLUDED, WITH Sn63) MTC100 SERIES
DECIMALS .XXX ± .005 [0,13mm] .XX ± .02 [0,51mm]	APPROVED	P.D.	2-7-94	SIZE	CODE IDENT. NO.	REV
ANGLES .X ±	CAD NAME	008080-1.DWG		C	06090	B
WEIGHT lbs [g]	THIRD ANGLE PROJECTION			DWG. NO. MTC100-BXMT-001-310		DO NOT SCALE THIS DRAWING
				SHEET 1 OF 2		

4

3

2

1

SHEET 1
DWG NO. MTC100-BXMT-001-310

4

3

2

1

SPECIFICATION

REFER TO RAYCHEM SPECIFICATION D6012 FOR DETAILED PERFORMANCE REQUIREMENTS AND TEST PROCEDURES. REQUIREMENTS AND PROCEDURES ARE IDENTICAL TO THOSE FOR D6012 CONNECTORS UNLESS OTHERWISE SPECIFIED HEREIN.

MATERIALS:

- A. HOUSING SHELL ALUMINUM ALLOY PER QQ-A-591
- B. ADAPTOR SCREW STAINLESS STEEL PER QQ-S-783, 300 SERIES
- C. ADAPTOR NUT STAINLESS STEEL PER QQ-S-783, 300 SERIES
- D. PANEL WASHER STAINLESS STEEL PER QQ-S-783, 300 SERIES
- E. DIELECTRIC INSERT INSERT MATERIAL HIGH GRADE POLYARYLENE THERMOPLASTIC
- F. FACE SEAL AND PANEL SEAL SILICONE ELASTOMER PER ZZ-R-765
- G. KEYING PIN POLYARYLENE THERMOPLASTIC, MOLDED
- H. PIN CONTACT COPPER ALLOY PER QQ-B-750
- J. SolderPak ® SEE RAYCHEM DRAWINGS D-704-0046, AND D-128-0031 FOR DETAIL INFORMATION (PARTS ARE SUPPLIED AS TWO (2) STRIPS OF TWENTY (20) PIECES EACH OF D-128-0031).

FINISH:

- A. HOUSING SHELL CADMIUM PLATED PER QQ-P-416 OVER NICKEL UNDERPLATE
- B. ADAPTOR SCREW CADMIUM PLATED PER QQ-P-416
- C. ADAPTOR NUT CADMIUM PLATED PER QQ-P-416
- D. PANEL WASHER CADMIUM PLATED PER QQ-P-416
- E. PIN CONTACT FINISH ON MATING END: GOLD PLATED PER MIL-C-45204, TYPE I, GRADE C, CLASS I
FINISH ON TERMINATION END: SUITABLE FOR Sn96 SOLDER TERMINATION

DESIGN AND CONSTRUCTION: (REF PARA 3.5)

THE CONNECTORS SPECIFIED HEREIN ARE PANEL MOUNTED RECEPTACLES WITH FIXED (NON REMOVABLE) PIN INSERTS AND CONTACTS. THE CONTACTS ARE SOLDER TAILS WITHOUT PROVISIONS FOR CABLE CLAMPS OR TERMINATION SEALS.

PERFORMANCE: (REF PARA 3.6)

PERFORMANCE SHALL BE IN ACCORDANCE WITH D6012 EXCEPT AS FOLLOWS:

HUMIDITY	PARA 3.6.17
ALTITUDE IMMERSION	PARA 3.6.18
ALTITUDE-LOW TEMPERATURE	PARA 3.6.19
FLUID IMMERSION	PARA 3.6.23

SOLDER TAILS MUST BE SUITABLY PROTECTED FROM THE ENVIRONMENT.

RATING:

TEMPERATURE	-65°C +150°C
VOLTAGE (AC)	375 V
CURRENT	5A

WEIGHT:

.056 LBS.

NOTES:

1. TWO KEYING PINS ARE SUPPLIED, NOT INSTALLED, WITH EACH RECEPTACLE. USER TO PRESS INTO PROPER KEYING POSITION (SEE TABLE I)

2. KEYING POSITION CODE DOES NOT FORM A PART OF THE RAYCHEM PART NUMBER AND SHOULD BE OMITTED WHEN ORDERING.

REVISIONS			
LTR	DESCRIPTION	DATE	APPROVED
	REFER TO SHEET 1 FOR REVISIONS		

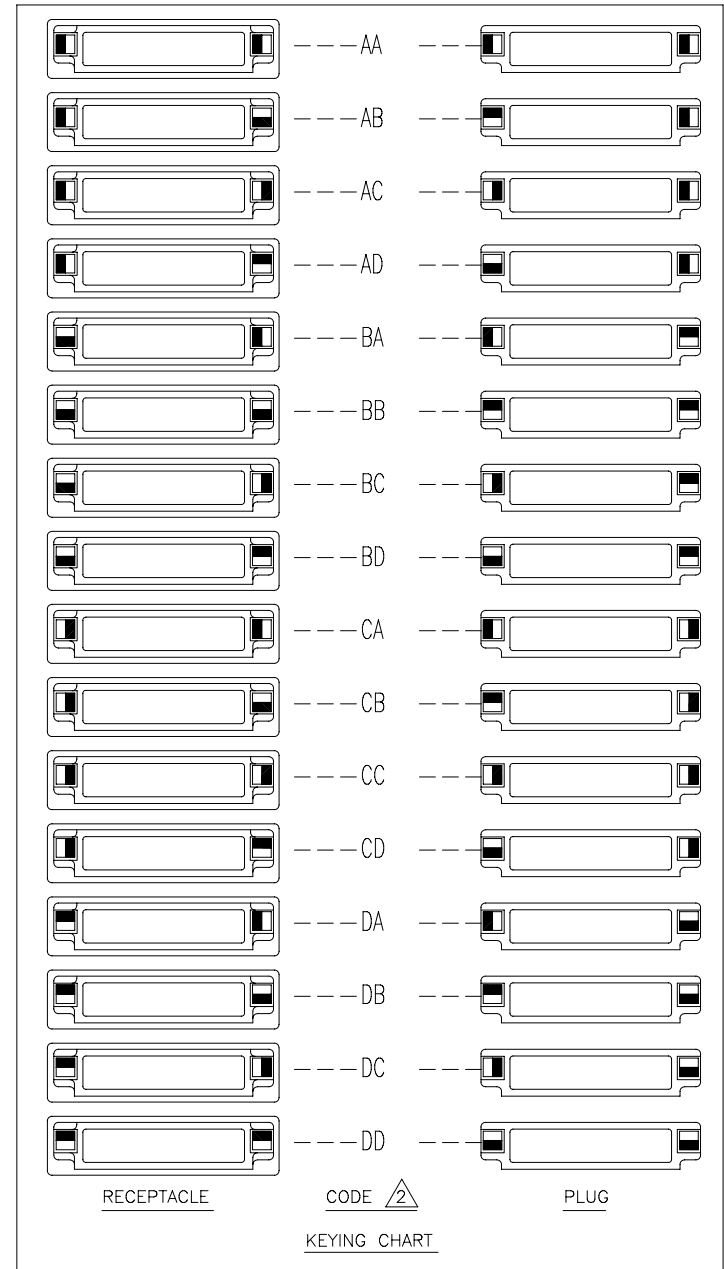

**If this document is printed it becomes uncontrolled.
Check with the web for latest revision.**

SIZE	CODE IDENT. NO.	DWG. NO.	REV
C	06090	MTC100-BXMT-001-310	B
DO NOT SCALE THIS DRAWING		CAD NAME: 008080-2.DWG	SHEET 2 OF 2

DWG NO. MTC100-BXMT-001-310 SHEET 2