

TIWI-UB2 EM BOARD

User Guide



Last updated

February 11, 2016

The information in this document is subject to change without notice.

Table of Contents

User Guide 1

1	Introduction	3
1.1	<i>Purpose & Scope.....</i>	3
1.2	<i>Applicable Documents.....</i>	3
1.3	<i>Revision History.....</i>	3
2	TiWi-uB2 Module Description.....	4
3	TiWi-uB2 EM Board Hardware.....	5
3.1	<i>Antenna</i>	5
3.2	<i>Connectors</i>	5
3.3	<i>Required Signals between EM Board and Host Device</i>	6
3.4	<i>Connecting EM Board to Host Platform</i>	7
3.5	<i>Power Supply.....</i>	7
3.6	<i>Serial Interfaces.....</i>	7
3.7	<i>HCI UART.....</i>	8
3.8	<i>PCM Interface.....</i>	8
3.9	<i>Option 1: Using EM Connectors.....</i>	8
3.10	<i>Option 2: Using Single Row Headers.....</i>	11
3.11	<i>Using J7 with USB to Serial Converter.....</i>	12
4	Schematic.....	13
4.1	<i>Bill Of Material (BOM).....</i>	14
5	Application Development.....	15
5.1	<i>Overview.....</i>	15
5.2	<i>Development Tools.....</i>	15
6	Contacting LS Research	20

1 Introduction

1.1 Purpose & Scope

The purpose of this document is to provide details regarding the setup and use of the TiWi-uB2 module on an EM board. This document covers a description of the EM board and its features and a brief tutorial on how to operate the module EM board.

1.2 Applicable Documents

- *TiWi-uB2 Datasheet (330-0100)*
- *TiWi-uB2 Antenna Design Guide (330-0106)*

1.3 Revision History

Date	Change Description	Revision
2/19/2012	Initial release	1.0
5/28/2013	Updated Figure 8 TiWi-uB2 EM Board Schematic	1.1

Table 1 Revision History

3 TiWi-uB2 EM Board Hardware

3.1 Antenna

The TiWi-uB2 EM Board contains an on board chip antenna which is modular certified for FCC 15.247 and IC RSS-210, as well as compliant to the RF requirements for ETSI EN 300 328 and ETSI EN 301 489. The antenna layout and circuitry on the EM Board can be replicated on a custom designed PCB assembly. Assuming the design/layout is followed exactly as that which is on the EM Board, the custom PCB will retain the modular certification. Below are details on the certifications.

FCC ID: TFB-BT1, 15.247

IC ID: 5969A-BT1, RSS 210

3.2 Connectors

There are two primary connectors on the TiWi-uB2 EM Board (J1 & J2). These provide a standard interface to Texas Instruments development platforms (See Section 3.9).

Two additional non populated connectors (J4 & J5) provide access to all of the significant signals on the module on a standard, single row 2mm pitch header.

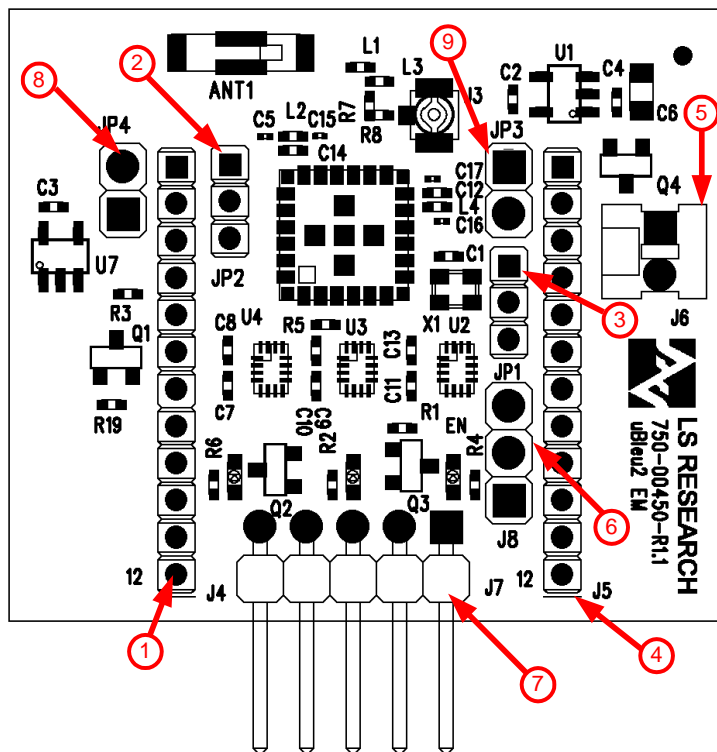

The information in this document is subject to change without notice.

Figure 3 TiWi-uB2 EM Board Top Side Connectors

Numbered Item	Connector	Description
1	J4	This is a non-populated connector that exposes signals from the module. Refer to Table 6 for more details.
2	JP2	This jumper is used to configure the audio PCM interface as a master or slave by switching the direction of the level shifter for the AUD_CLK and FSYNC signals.
3	JP1	This jumper is used to select the onboard 32kHz slow clock or external 32kHz slow clock.
4	J5	This is a non-populated connector that exposes signals from the module. Refer to Table 7 for more details.
5	J6	This connector is not populated by default. It can be used to power the EM board.
6	J8	This connector is not populated by default. It give the user access to 1.8V, GND, and SLOW_CLK_IN
7	J7	This connector is not populated by default. It is designed to be used with an external USB to Serial module. See section 3.11
8	JP4	This jumper is used to break 1.8V to the Module for VIO current measurements.
9	JP3	This jumper is used to break 3.3V to the Module for VBAT current measurements.

Table 2 TiWi-uB2 EM Board Top Side Connectors

3.3 Required Signals between EM Board and Host Device

In addition to power and ground, there are three signals required for connecting a TiWi-uB2 module to a host device. See Table 3 below for details on these connections.

Signal Name	Description
VCC	Power to the module (2.2 to 4.8 Volts)
GND	Ground
/SHUT_DN	Active low module reset which is an input to the module and an output from the host device.
HCI_TX	HCI UART transmit pin which is an output from the module and an input to the host device.
HCI_RX	HCI UART receive pin which is an input to the module and an output from the host device.

Table 3 TiWi-uB2 Required Connections

The information in this document is subject to change without notice.

3.4 Connecting EM Board to Host Platform

The TiWi-uB2 EM Board is intended to allow for evaluation of and early development with a TiWi-uB2 module. The EM Board has two “EM” connectors on the bottom of the board that allows for easy connection to various Texas Instruments microcontroller development platforms. The primary development platform is the MSP430F5438 Experimenter Board.

It is also possible to adapt the TiWi-uB2 EM Board to work with microcontroller platforms that do not have support for the EM connectors. Sections 3.9 and 3.10 describe the two options for adapting an EM Board to work with other microcontroller platforms.

3.5 Power Supply

3.5.1 VBAT

VBAT requires a 3.0V to 4.8V DC power supply.

3.5.2 VDD_IO

VDD_IO requires a 1.8V DC power supply.

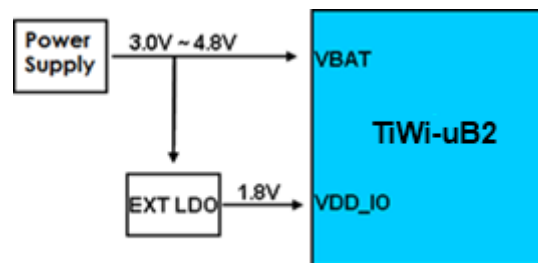

Figure 4 Power Supply

3.6 Serial Interfaces

There are two serial interfaces to the module, HCI UART and PCM. Each interface is described below.

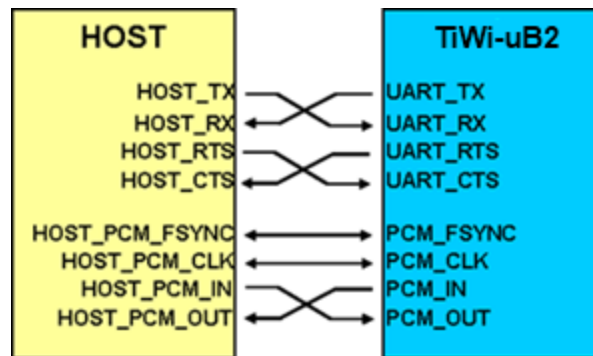

Figure 5 Serial Interfaces

3.7 HCI UART

This is the main interface between the host microcontroller and the module. The Bluetooth UART may also be used to download external patches from the host to the TiWi-uB2. The UART interface supports baud rates from 9600bps to 4Mbps.

BT debug pin: The debug interface (TX_DBG) helps customers to debug the HW/SW issues for their application (not pictured).

3.8 PCM Interface

The PCM Interface can connect to linear PCM Codec devices in master or slave mode. In master mode, the TiWi-uB2 generates the PCM_CLK and PCM_SYNC signals, and in slave mode, these signals are provided by another master on the PCM interface and are inputs to the TiWi-uB2.

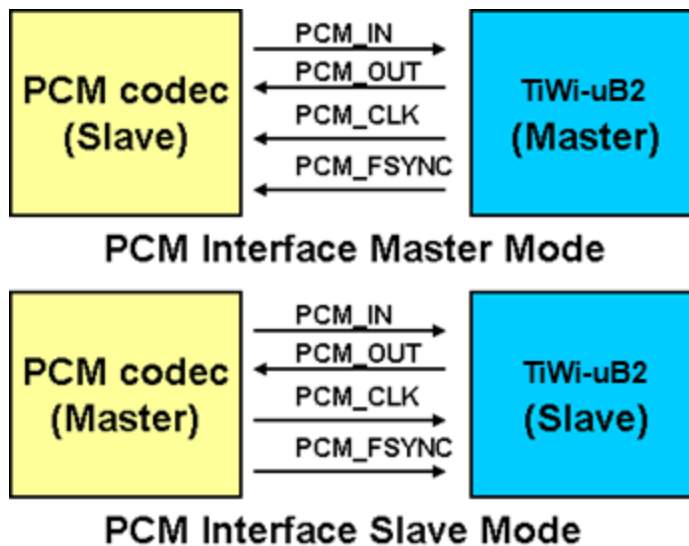

Figure 6 PCM Interface

3.9 Option 1: Using EM Connectors

Either build a PCB which has the EM Board mating connectors which will allow for plugging the TiWi-uB2 EM Board into, or solder wires to EM Board mating connectors that can then be wired into whatever development platform is being used.

Below are two suggestions for the mating EM connectors.

Through hole connector: Samtec TFM-110-01-S-D-WT

Surface Mount connector: Samtec SFM-110-02-L-D-A

If building a PCB that has the mating EM Board connectors, the connectors need to be lined up and spaced 1.2" apart as shown in Figure 7.

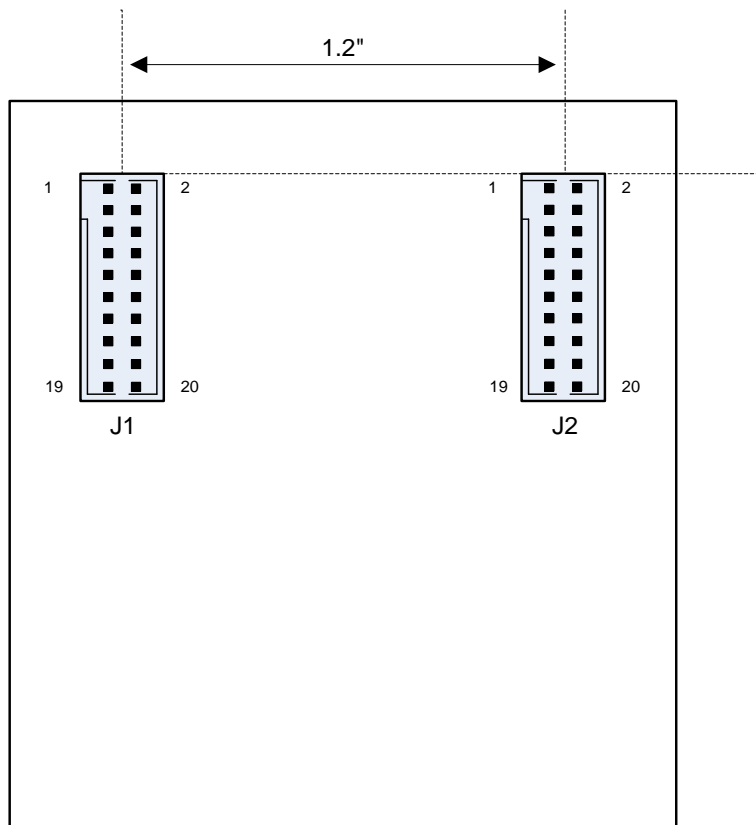

Figure 7 Host PCB EM Mating Connector Arrangement (Top View)

Refer to Table 4 and Table 5 below for details on the signals brought out to the EM connectors J1 and J2.

J1 Pin Number	Pin Name	Module Pin Type	Description
1, 19	GND		Ground
3	HCI_CTS	DI	HCI UART CTS pin. This should be controlled by the host UART RTS pin. (VCC logic level)
5	SLOW_CLK	DI	External slow clock input. If the user does not want to use the 32kHz clock on the EM board, an external clock can be supplied on this pin. (VCC logic level)
7	HCI_RX	DI	HCI UART receive pin. This should be connected to the host UART transmit pin. (VCC logic level)
9	HCI_TX	DO	HCI UART transmit pin. This should be connected to the host UART receive pin. (VCC logic level)

Table 4 EM Connector J1

The information in this document is subject to change without notice.

J2 Pin Number	Pin Name	Module Pin Type	Description
2	GND		Ground
7, 9	VCC	PI	Power to the module.
8	AUD_OUT	DO	PCM data output (VCC logic level)
10	AUD_IN	DI	PCM data input (VCC logic level)
11	FSYNC	DIO	PCM frame sync (VCC logic level)
17	AUD_CLK	DIO	PCM clock (VCC logic level)
18	HCI_RTS	DO	HCI UART RTS pin. This should be connected to the host UART CTS pin. (VCC logic level)
19	/SHUT_DN	DI	Module shutdown pin (active low, VCC logic level)

Table 5 EM Connector J2

DI = Digital Input; DO = Digital Output; DIO = Digital Input/Output; PI = Power Input

3.10 Option 2: Using Single Row Headers

Solder single row 12 pin 2mm headers into locations J4 and J5 on the EM Board, and then build a wiring harness between the headers on the EM Board and the microcontroller development platform of interest.

Below is a suggestion for the 12 pin 2mm headers.

Sullins NRPN121PAEN-RC

Refer to Table 6 and Table 7 below for details on the signals brought out to the single row headers J4 and J5.

J4 Pin Number	Pin Name	Module Pin Type	Description
1	NC		No Connect, leave this pin unconnected.
2	HCI_CTS	DI	HCI UART CTS input (VCC logic level). Connect to host UART RTS pin.
3	HCI_RTS	DO	HCI UART RTS output (VCC logic level). Connect to host UART CTS pin.
4	HCI_TX	DO	HCI UART transmit pin (VCC logic level). Connect to host UART receive pin.
5	HCI_RX	DI	HCI UART receive pin (VCC logic level). Connect to host UART transmit pin.
6	NC		No Connect, leave this pin unconnected.
7	GND		Ground
8	/SHUT_DN	DI	Active low module shut down (VCC logic level) that should be controlled by the host device.
9	/SHUT_DN_1.8V	DI	Active low module shut down (1.8V side of level shifter).
12	GND		Ground

Table 6 Single Row Header J4

DI = Digital Input; DO = Digital Output; PI = Power Input

J5 Pin Number	Pin Name	Module Pin Type	Description
1	FSYNC	DIO	PCM frame sync (VCC logic level)
2	AUD_CLK	DIO	PCM clock (VCC logic level)
3	AUD_OUT	DIO	PCM data output (VCC logic level)
4	AUD_IN	DIO	PCM data input (VCC logic level)
5	VCC	PI	2.2 to 3.6 Volts
6	NC		No Connect, leave this pin unconnected.
7	GND		Ground
8	SLOW_CLK_3.3V	DO	External 32.768kHz clock input (VCC logic level)
9	TX_DBG	DO	Debug UART. Internal use only. (VCC logic level)
10	VIO	PI	1V8 VIO supply
11	1V8_PG	PI	1V8 power good signal. Used to enable level shifters.
12	GND	GND	Ground

Table 7 Single Row Header J5

DI = Digital Input; DO = Digital Output; DIO = Digital Input/Output; PI = Power Input

3.11 Using J7 with USB to Serial Converter

J7 is provided for interfacing the TiWi-uB2 Module to a USB-to-Serial converter, or similar serial device capable of providing 1.8V logic level data.

J7 Pin Number	Pin Name	Module Pin Type	Description
1	1.8V	PI	1.8V DC from EM board
2	NC		No Connect, leave this pin unconnected.
3	GND	GND	System Ground
4	HCI_TX_1.8V	DO	UART TX 1.8V Logic Level. Connect to host UART receive pin.
5	HCI_RX_1.8V	DI	UART RX 1.8V Logic Level. Connect to host UART transmit pin.

Table 8 Single Row Header J7

DI = Digital Input; DO = Digital Output; DIO = Digital Input/Output; PI = Power Input;

4.1 Bill Of Material (BOM)

Reference	Pop Opt	Part Number	Description
ANT1		2450AT43B100	CHIP ANTENNA 2.4GHz
C1-4 C7-11 C13		GRM155R71C104KA88	0402 SIZE SMT CERAMIC CAPACITOR
C12 C14	NP	GRM155R71C104KA88	0402 SIZE SMT CERAMIC CAPACITOR
C5 C15 C17	NP	250R05L0R3AV4T	0201 SIZE SMT CERAMIC CAPACITOR
C6		GRM21BR71C105KA01L	CAP CER 1.0UF 16V 20% X7R 0805
C16		250R05L2R4BV4T	0201 SIZE SMT CERAMIC CAPACITOR
J1 J2		SFM-110-02-L-D-A	SOCKET STRIP,.050" (1.27mm) PITCH, SMT
J3		U.FL-R-SMT(01)	MINIATURE COAXIAL RECEPTACLE
J4 J5	NP	NRPN121PAEN-RC	12 PIN 2MM HEADER
J6	NP	640456-2	2 PIN 0.1" POLARIZED FRICTION LOCK
J7	NP	PTC05SGBN	5 PIN 0.1" HEADER
J8	NP	PBC03SAAN	3 PIN 0.1" HEADER
JP1 JP2		NRPN031PAEN-RC	3 PIN 2MM HEADER
JP3 JP4		PBC02SAAN	2 PIN 0.1" HEADER
JMP1 JMP2		M22-1900005	2.0 mm SHUNT JUMPER
JMP3 JMP4		M7567-05	.1" SHUNT JUMPER
L1		L-07C2N7SV6T	MONOLITHIC 0402 SIZE SMT INDUCTOR
L2		ERJ-2GE0R00X	RES 0.0 OHM 1/10W 0402 SMD
L3		L-07C2N2SV6T	MONOLITHIC 0402 SIZE SMT INDUCTOR
L4		L-07C5N6KV6T	MONOLITHIC 0402 SIZE SMT INDUCTOR
LED1		APTD1608CGCK	LIGHT EMITTING DIODE, 0603 SMT, GREEN
LED2		APTD1608SYCK	LIGHT EMITTING DIODE, 0603 SMT, YELLOW
LED3		APTD1608QBC/D	LIGHT EMITTING DIODE, 0603 SMT, BLUE
MOD1		450-0104	TiWi-uB2 Module
MOD2	NP	DLP-TXRX-G	USB to Serial Adapter
Q1-3		FDV301N	N-CHANNEL LOGIC LEVEL ENHANCEMENT
Q4		FDN340P	P-CHANNEL POWER TRENCH MOSFET
R1 R3		ERJ-2GEJ104X	THICK FILM 0402 SMT RESISTOR
R2		ERJ-2RKF4020X	THICK FILM 0402 SMT RESISTOR
R4 R6		ERJ-2GEJ271X	THICK FILM 0402 SMT RESISTOR
R5 R19		ERJ-2GEJ103X	THICK FILM 0402 SMT RESISTOR
R7		ERJ-2GE0R00X	RES 0.0 OHM 1/10W 0402 SMD
R8	NP	ERJ-2GE0R00X	RES 0.0 OHM 1/10W 0402 SMD
R9 - R18			0402 SMT RESISTOR PLACE Holder
U1		TPS73118MDBVREP	150mA LOW DROPOUT LINEAR REGULATOR
U2 U3 U4		SN74AVC4T245RSVR	4-BIT DUAL SUPPLY BUS TRANSCEIVER
U7		NCP303LSN09T1G	VOLTAGE DETECTOR
X1		ASDK2-32.768KHZ-LRT	CRYSTAL OSCILLATOR

Table 9 TiWi-uB2 EM Board BOM

The information in this document is subject to change without notice.

5 Application Development

5.1 Overview

The TiWi-uB2 EM Board used in conjunction with a Bluetooth stack running on TI's MSP430BT5438 or Stellaris LM3S9B96 microcontroller (MCU) will reduce design barriers and provides a highly flexible platform to enable customer's early prototyping capabilities of embedded Bluetooth applications. The ready-to-go wireless platforms simplify the development process of pre-integrated and pre-validated Bluetooth serial link on an MSP430BT5438 or LM3S9B96 system.

For an overview of development platforms and software examples see [CC256x Bluetooth](#).

5.2 Development Tools

5.2.1 MSP430 Hardware

Hardware required for initial evaluation and development include:

- 2 - TiWi-uB2 EM Boards



- 1 - TI [MSP430 USB Debugging Interface](#)



- 2 - TI [MSP430F5438 Experimenter Boards](#)

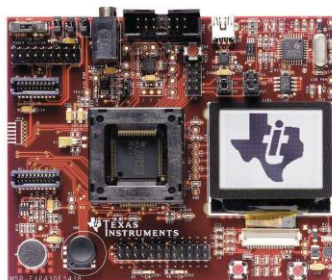

MSP-EXP430F5438
MSP430F5438 Experimenter Board

The information in this document is subject to change without notice.

5.2.2 Stellaris Hardware

- 1 - TiWi-uB2 EM Board



- 1 - TI [MSP430 USB Debugging Interface](#)



- 1 - TI [Stellaris LM3S9B96 EM2 Expansion Board](#)



- 1 - TI [DK-LM3S9D96](#)



5.2.3 Software

Software required for initial evaluation and development include:

Stellaris

- [Bluetopia®+LE SDK](#)
- [CC256x Bluetopia Stack](#)
- [Stellaris DK-LM3S9B96 SDK](#)

Integrated BT Profiles

- Classic Bluetooth
 - SPP
 - A2DP



Figure 9 TiWi-uB2 EM Board with Stellaris DK-LM3S9B96

MSP430

Bluetopia

- [Bluetopia®+LE SDK](#)
- [CC256x Bluetopia Stack](#)
- [CC256x MSP430 Bluetopia Basic Demo APPS](#)

Integrated BT Profiles

- Classic Bluetooth
 - SPP
- Bluetooth Low Energy
 - GATT
 - ANP
 - HRP
 - HTP
 - PASP

This Bluetooth software solution is licensed from Stonestreet One. The Bluetopia®+LE SDK is comprised of Single Mode and Dual Mode offering implementing the Bluetooth 4.0 specification. Bluetopia®+LE stack is built upon the solid foundation of the Bluetopia protocol stack that is currently being used in millions of consumer and industrial devices and that was first qualified in 2000`

[TiWi-uB2 + MSP430 Bluetopia Basic Demo APPS](#) allows users to evaluate TI's CC256x Bluetooth device by using the TiWi-uB2 EM board and the MSP-EXP430F5438 board. The CC256x+MSP430 Bluetooth sample applications code are provided to enable a rich out-of-box experience to the user. The application allows the user to use a console to send Bluetooth commands, setup a Bluetooth Device to accept connections, connect to a remote Bluetooth device and communicate over Bluetooth.

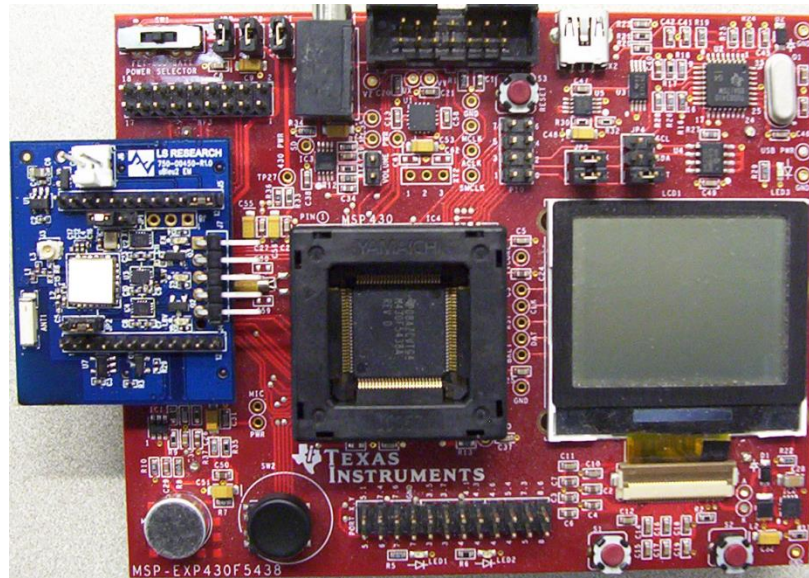

Figure 10 TiWi-uB2 EM Board with MSP430F5438 Experimenter Board

6 Contacting LS Research

Headquarters	LS Research, LLC W66 N220 Commerce Court Cedarburg, WI 53012-2636 USA Tel: 1(262) 375-4400 Fax: 1(262) 375-4248
Website	www.lsr.com
Wiki	www.lsr.com/products-wiki
Technical Support	www.lsr.com/products-forum
Sales Contact	sales@lsr.com

The information in this document is provided in connection with LS Research (hereafter referred to as “LSR”) products. No license, express or implied, by estoppel or otherwise, to any intellectual property right is granted by this document or in connection with the sale of LSR products. EXCEPT AS SET FORTH IN LSR’S TERMS AND CONDITIONS OF SALE LOCATED ON LSR’S WEB SITE, LSR ASSUMES NO LIABILITY WHATSOEVER AND DISCLAIMS ANY EXPRESS, IMPLIED OR STATUTORY WARRANTY RELATING TO ITS PRODUCTS INCLUDING, BUT NOT LIMITED TO, THE IMPLIED WARRANTY OF MERCHANTABILITY, FITNESS FOR A PARTICULAR PURPOSE, OR NON-INFRINGEMENT. IN NO EVENT SHALL LSR BE LIABLE FOR ANY DIRECT, INDIRECT, CONSEQUENTIAL, PUNITIVE, SPECIAL OR INCIDENTAL DAMAGES (INCLUDING, WITHOUT LIMITATION, DAMAGES FOR LOSS OF PROFITS, BUSINESS INTERRUPTION, OR LOSS OF INFORMATION) ARISING OUT OF THE USE OR INABILITY TO USE THIS DOCUMENT, EVEN IF LSR HAS BEEN ADVISED OF THE POSSIBILITY OF SUCH DAMAGES. LSR makes no representations or warranties with respect to the accuracy or completeness of the contents of this document and reserves the right to make changes to specifications and product descriptions at any time without notice. LSR does not make any commitment to update the information contained herein. Unless specifically provided otherwise, LSR products are not suitable for, and shall not be used in, automotive applications. LSR’s products are not intended, authorized, or warranted for use as components in applications intended to support or sustain life.

The information in this document is subject to change without notice.