

THIS DRAWING IS UNPUBLISHED. RELEASED FOR PUBLICATION ,19 .  
 © COPYRIGHT 19 BY AMP INCORPORATED. ALL INTERNATIONAL RIGHTS RESERVED.

LOC	DIST	P	F	ZONE	LTR	DESCRIPTION	DATE	APPD
G	14				B	REV / 0610-0026-99	12FEB99	MLE SU

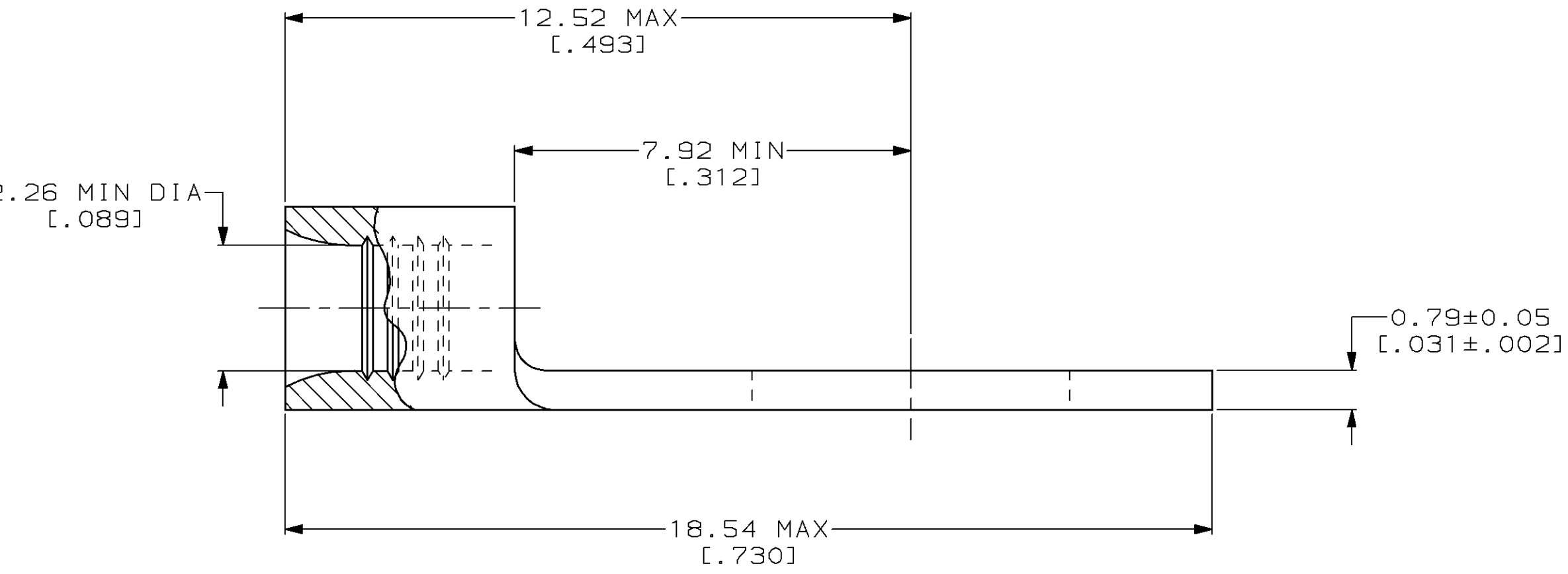
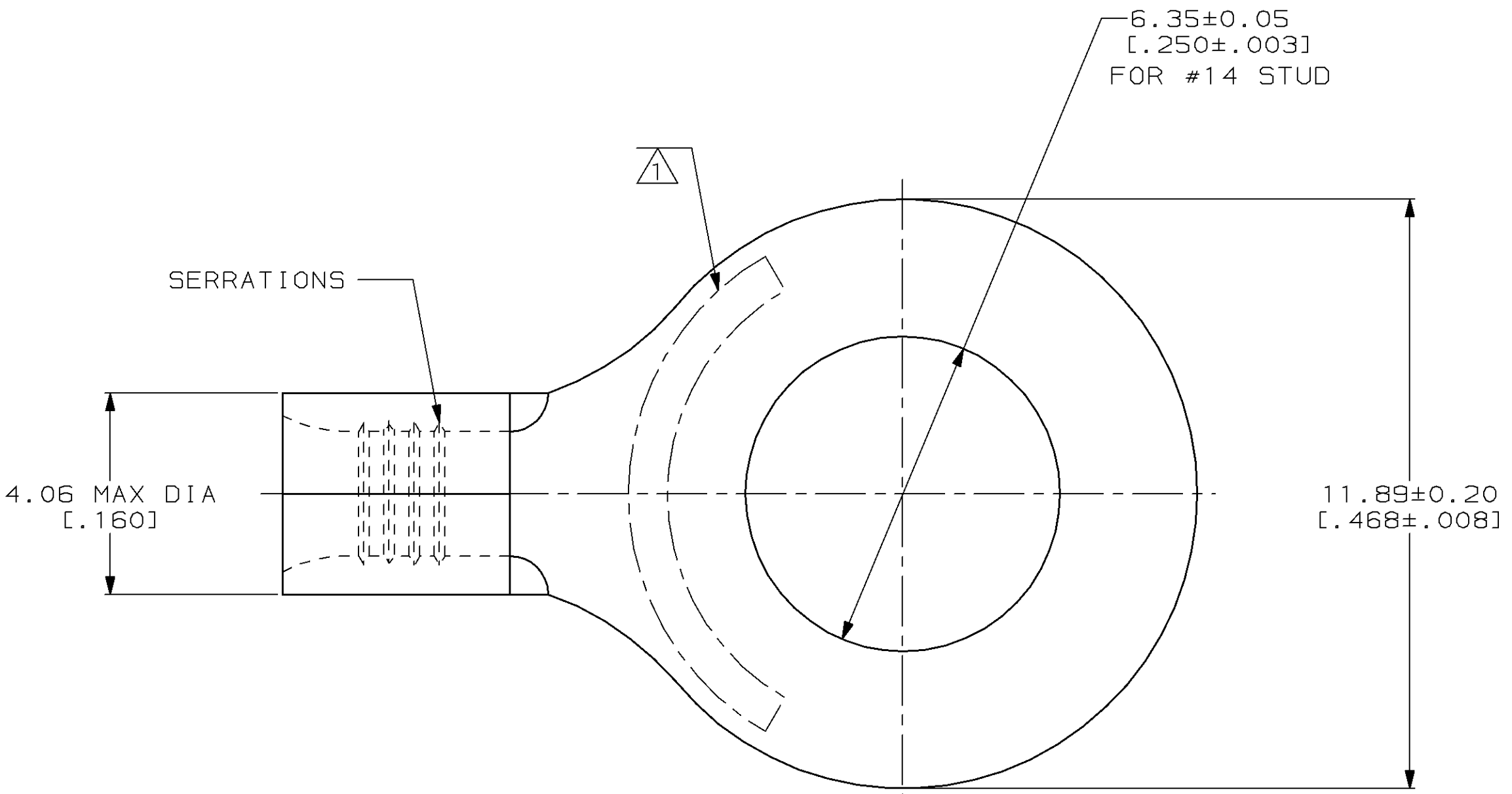

<b>AMP</b> WIRE RANGE	<b>UL</b> E13288 Listed
16-14 AWG STRANDED	16-14 AWG STRANDED
<b>CS</b> LR7189 Certified	MILITARY P/N AND CLASS
NOT CERTIFIED	NOT APPLICABLE

① STAMP AMP 16-14\* APPROX AS SHOWN

AMP INCORPORATED CUSTOMER SERVICE SYSTEMS		MAX RECOMMENDED OPERATING TEMPERATURE: 170°C MAX	DO NOT SCALE PRINT. UNLESS SPECIFIED DIMENSIONS IN mm [INCHES] TOLERANCES ON: 2 PLC DEC ± - 3 PLC DEC ± - ANGLES ± -	DR 2-5-93 TA BRINKMAN	<b>AMP</b> AMP Incorporated Harrisburg, PA 17105-3608
FOR ADDITIONAL PRODUCT INFORMATION OR COPIES OF DRAWINGS AND TECHNICAL DOCUMENTS	PRODUCT INFORMATION CENTER 1-800-522-6752	VOLTAGE RATING: NOT APPLICABLE	MATERIAL COPPER PER ASTM B-152 ANNEALED	CHK 2-5-93 DA PATTERSON	
FOR APPLICATION TOOLING INFORMATION	TOOLING ASSISTANCE CENTER 1-800-722-1111	WIRE CROSS SECTIONAL AREA RANGE: 1.04-2.62mm <sup>2</sup> [2,050-5,180] CIR MILS STRANDED	FINISH TIN PLATE 0.00254[.000100] MIN THK PER ASTM B-545	APPD 2-5-93 DE MILLER	NAME TERMINAL, RING TONGUE, BUDGET
FOR ORDER ENTRY	1-800-526-5142	THIS DRAWING IS A CONTROLLED DOCUMENT FOR AMP INCORPORATED. IT IS SUBJECT TO CHANGE AND THE CONTROLLING ENGINEERING ORGANIZATION SHOULD BE CONTACTED FOR THE LATEST REVISION.		APPD 2-5-93 JL MECKLEY	PRODUCT SPEC -
				APPLICATION SPEC -	SIZE C 00779
				WEIGHT -	DRAWING NO C=34896
					SCALE 10:1
					SHEET 1 OF 1