

THIS DRAWING IS UNPUBLISHED. RELEASED FOR PUBLICATION
 © COPYRIGHT - By - ALL RIGHTS RESERVED.

REVISIONS					
P	LTR	DESCRIPTION	DATE	DWN	APVD
B1		REVISED PER ECO-16-004800	12SEP2016	NK	MZ

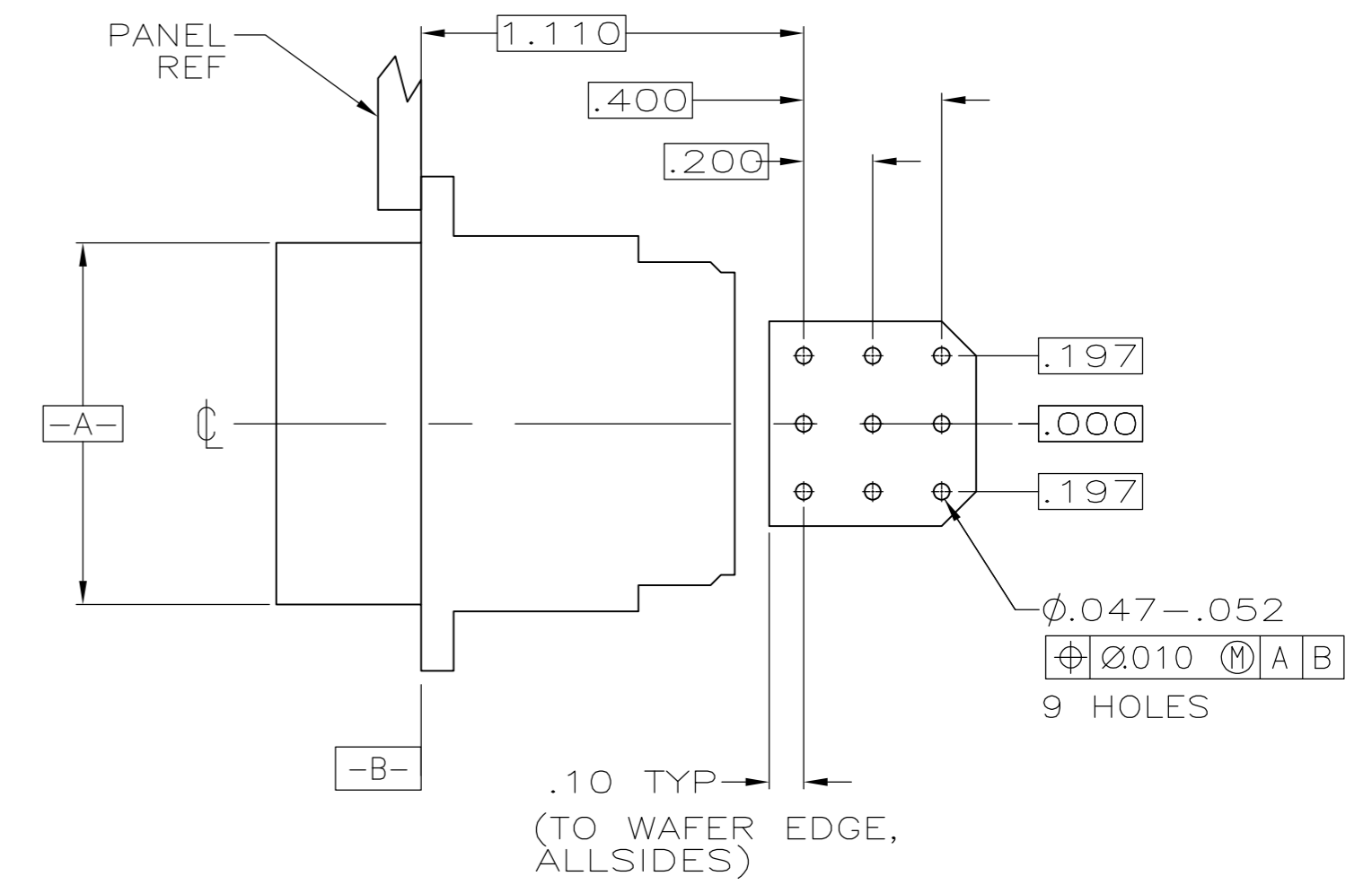

VIEW A-A \triangle
 RECOMMENDED PC BOARD LAYOUT

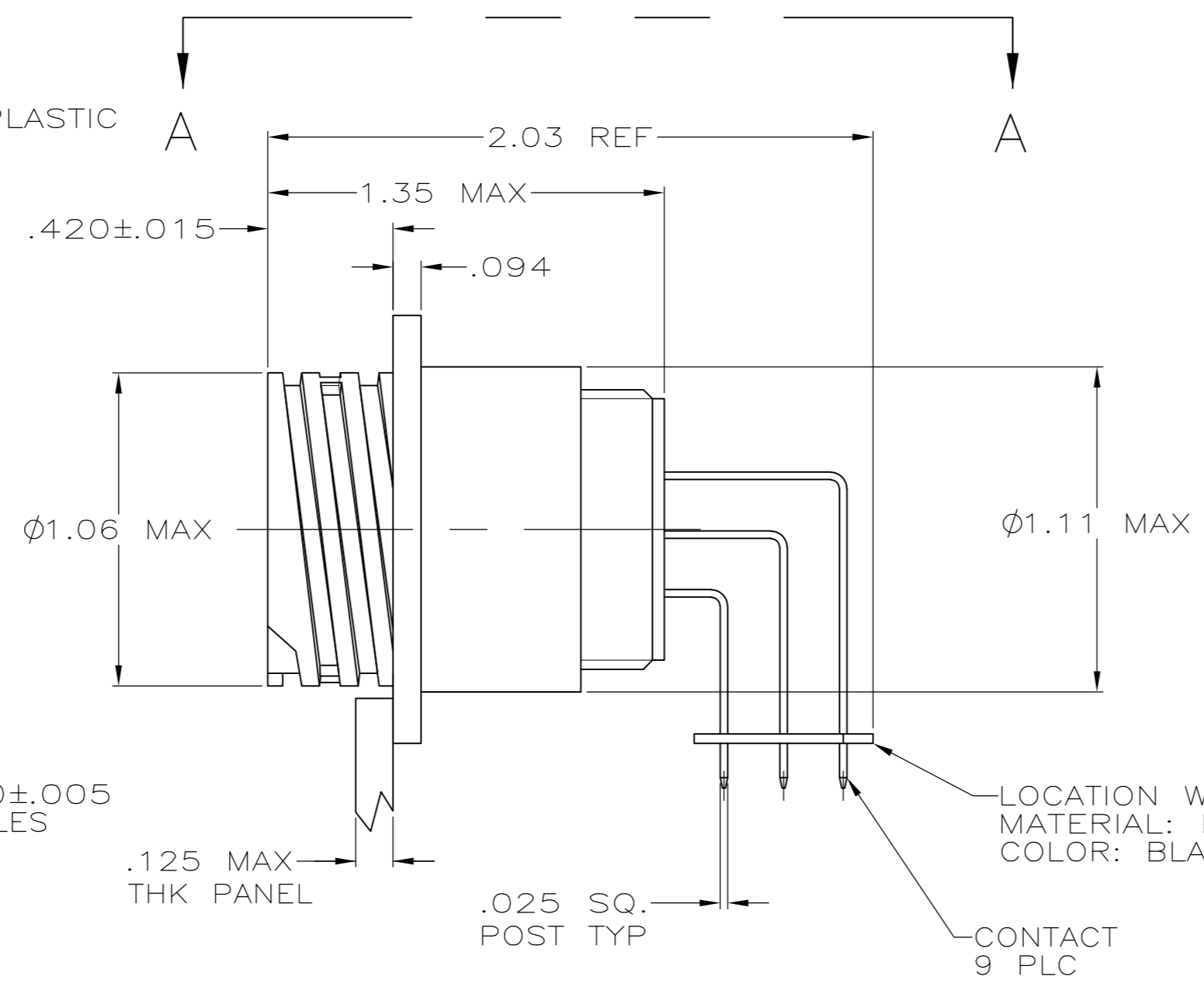
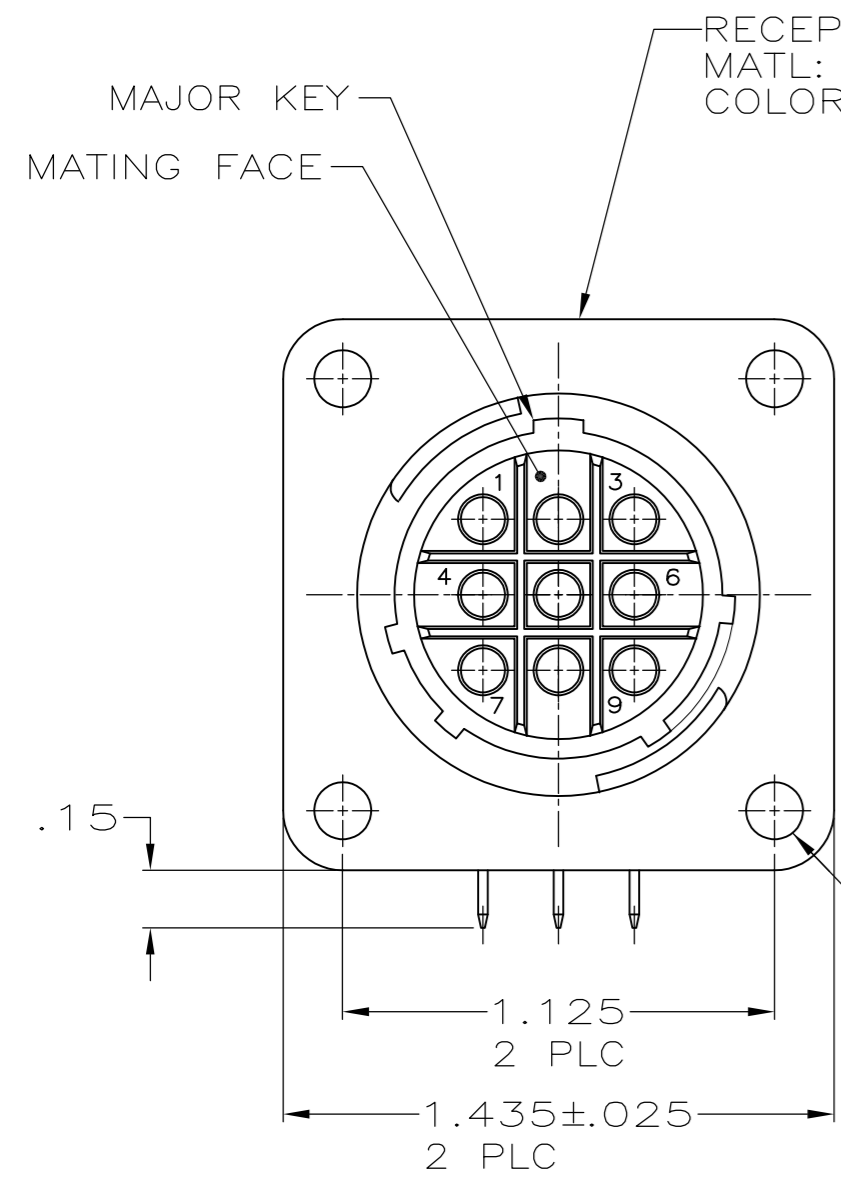
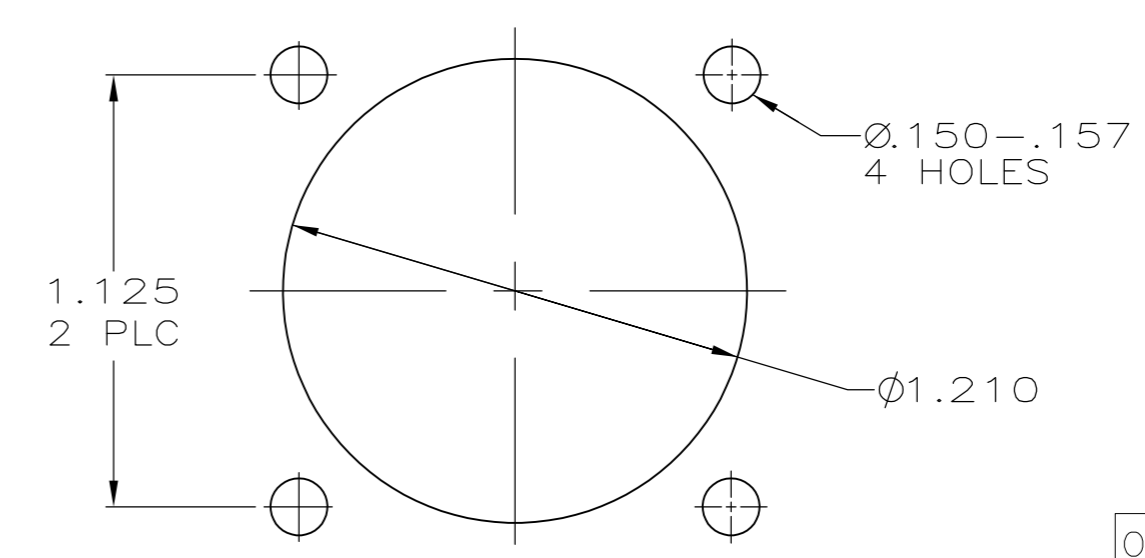

RECOMMENDED
 PANEL CUTOUT

- 1 CONTACT CAVITIES IDENTIFIED BY CHARACTERS ON FRONT AND REAR FACES OF CONNECTOR.
- 2 #6 FASTENER RECOMMENDED FOR MOUNTING.
- \triangle 3 CONTACT BODY: .000030 MIN GOLD FOR A LENGTH OF .250 MIN FROM MATING END, WITH REMAINDER TO BE GOLD FLASH, BOTH OVER .000050 MIN NICKEL.
CONTACT POST: .000100 MIN TIN-LEAD OVER .000100 MIN COPPER.
- \triangle 4 PC BOARD HOLE PATTERN IS DEFINED RELATIVE TO CONNECTOR C.L. AND PANEL MOUNTING FACE INDICATED.
- \triangle 5 CONTACT BODY: .000030 MIN GOLD FOR A LENGTH OF .250 MIN FROM MATING END, WITH REMAINDER TO BE GOLD FLASH, BOTH OVER .000050 MIN NICKEL.
CONTACT POST: .000100 MIN TIN OVER .000100 MIN COPPER.

OBSOLETE	\triangle 5	-1-796497-1
	\triangle 3	796497-1
	CONTACT FINISH	PART NUMBER

THIS DRAWING IS A CONTROLLED DOCUMENT.		DWN HAMMER 4-13-00	TE Connectivity	
DIMENSIONS: INCHES		CHK M.CHACKO 4-18-00	NAME	
TOLERANCES UNLESS OTHERWISE SPECIFIED:		APVD M.CHACKO 4-18-00	RECEPTACLE ASSY, POSTED, RT ANGLE, STD SEX, SIZE 17-9, SERIES 1, CPC	
0 PLC ± -		PRODUCT SPEC	SIZE	RESTRICTED TO
1 PLC ± -		APPLICATION SPEC	CAGE CODE	
2 PLC ± .03			DRAWING NO	
3 PLC ± .010			A2 00779	
4 PLC ± -			C=796497	
ANGLES ± -		WEIGHT	SCALE	SHEET
FINISH		CUSTOMER DRAWING	2:1	1 OF 1
			REV	B1