

THIS DRAWING IS UNPUBLISHED. RELEASED FOR PUBLICATION .19  
 © COPYRIGHT 19 BY AMP INCORPORATED, HARRISBURG, PA. ALL INTERNATIONAL RIGHTS RESERVED. AMP PRODUCTS MAY BE COVERED BY U.S. AND FOREIGN PATENTS AND/OR PATENTS PENDING.

LOC	DIST	REVISIONS						
		P	F	ZONE	LTR	DESCRIPTION	DATE	APPROVED
AF	50			M		REVISED AF-7561	8/8/91	JR/RB

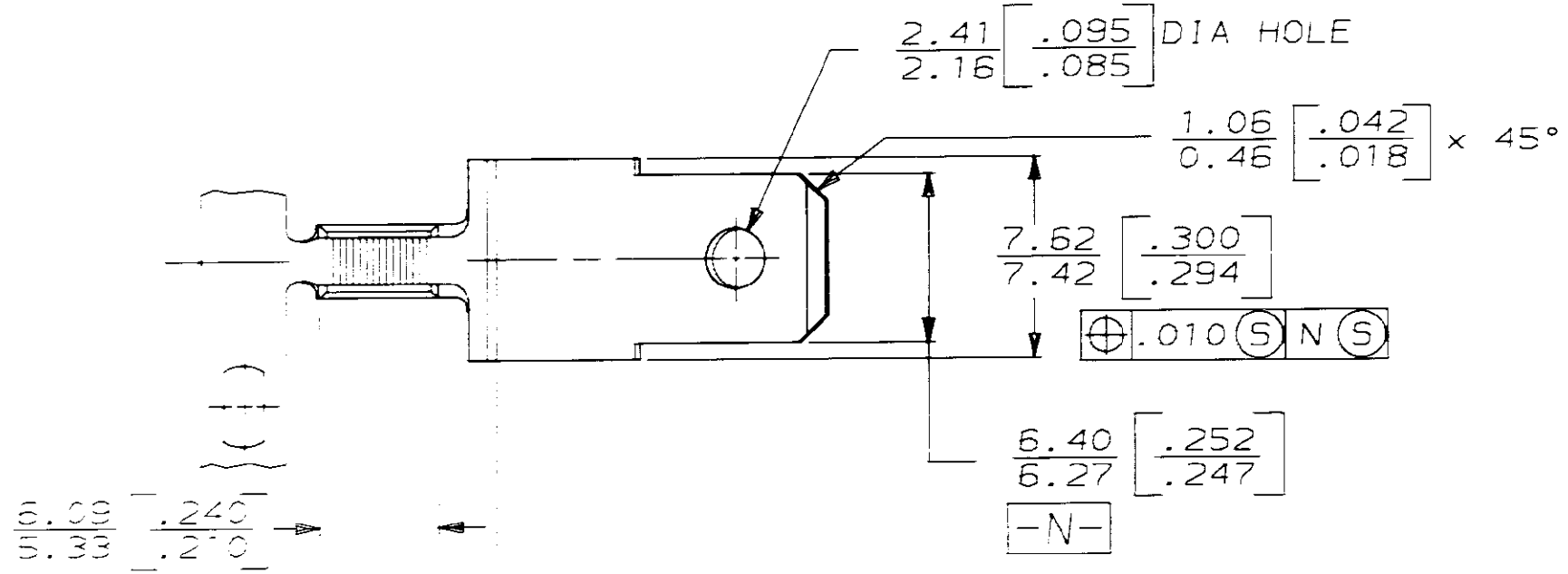

1- DIMENSIONS IN BRACKETS ARE IN INCHES.  
 2- CONTINUOUS STRIP ON REELS.

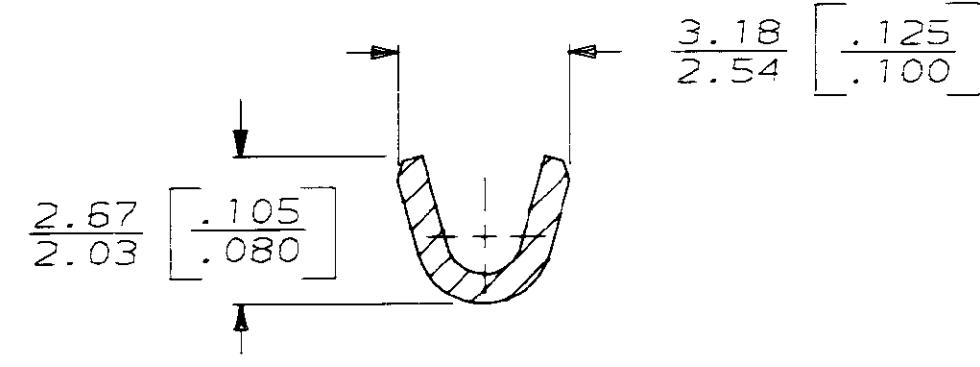

SECTION A-A

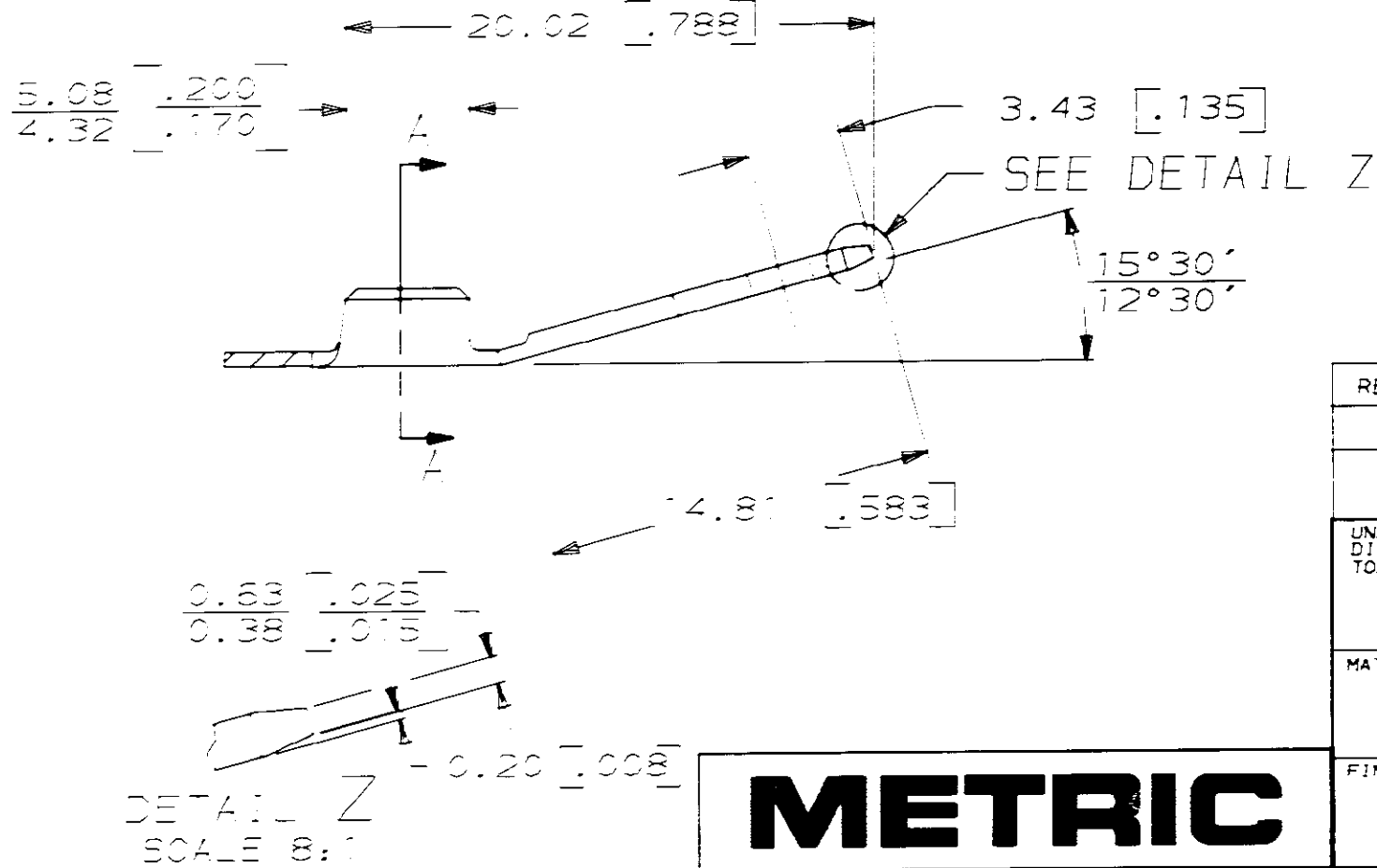

REVERSE REEL	0.81 ±0.025 [.032] ±.001 PRE-MILLED TO 0.51 ±0.025 [.020] ±.001	0.91-0.57 MM DIA [19-23]	63165-2 63165-1
REELING	MATERIAL	WIRE BARREL	PART NO
UNLESS OTHERWISE SPECIFIED DIMENSIONS ARE IN INCHES TOLERANCES ON: 2 PL DEC ± _____ 3 PL DEC ± .010 ANGLES ± _____		AMP INCORPORATED Harrisburg, Pa. 17105	
MATERIAL	DR JR RUTH 3-21-86 CHK G YETTER 3-21-86 APPD C MEYERS 3-21-86 APPD R KUZO 3-21-86	NAME .250 FASTON AMPLIVAR TAB	
FINISH	PRODUCT SPEC APPLICATION SPEC	SIZE B	FSCM NO 00779 DRAWING NO 63165
	TIN	SCALE NTS	SHEET 1 OF 1

**METRIC**

CUSTOMER DRAWING