

REVISIONS

NO	DESCRIPTION	DATE	APPD
1	REVISED PER 0720-0230-93	2/28/94	DAP

**METRIC**  
 DIMENSIONS LISTED IN MM [ INCHES ]

<b>AMP</b> WIRE RANGE	<b>UL</b> E13288 Listed
22-16 AWG STRANDED	22-16 AWG STRANDED
<b>LR7189</b> Certified	MILITARY P/N AND CLASS
NOT CERTIFIED	NOT APPLICABLE

STAMP AMP 22-18\* APPROX AS SHOWN  
 22-16 TERMINALS ARE STAMPED 22-18 IN  
 ACCORDANCE WITH MILITARY SPECIFICATION  
 MIL-T-7928, COMMERCIAL WIRE RANGE IS 22-16

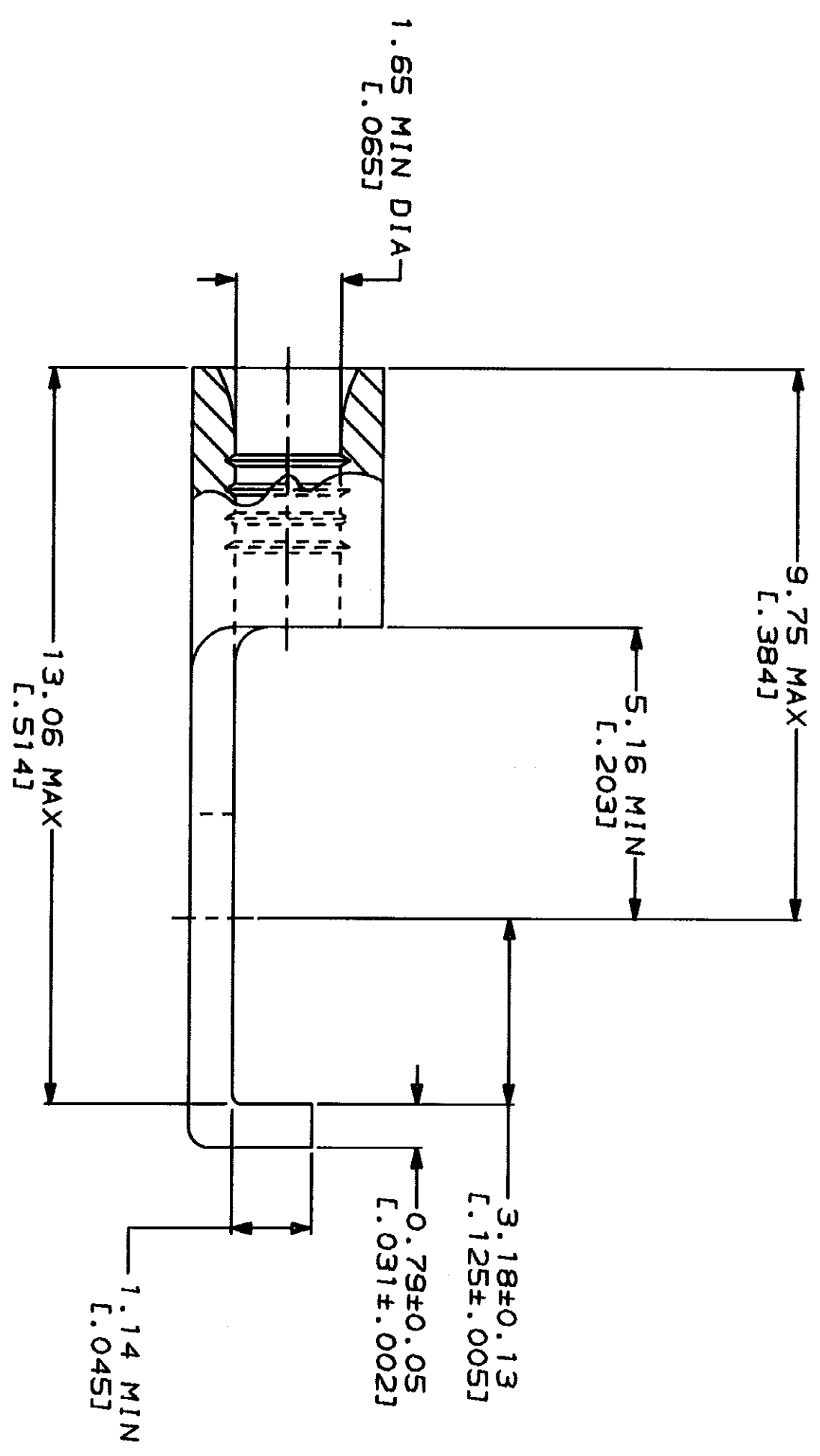
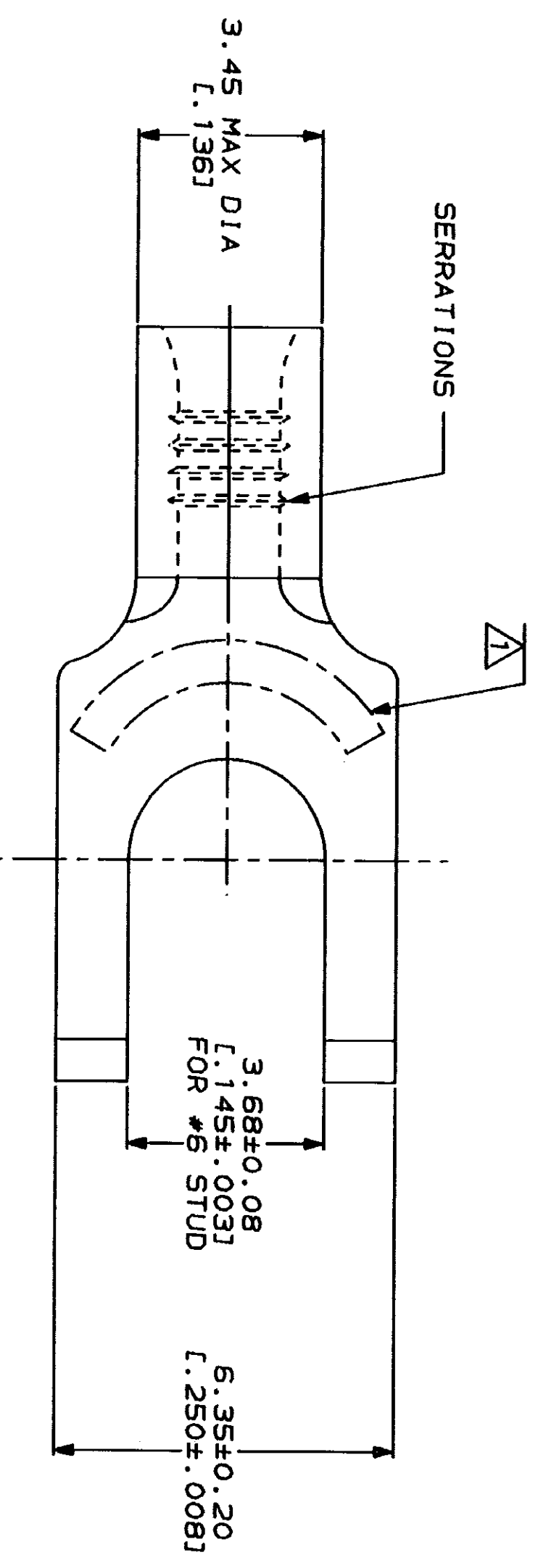

AMP INCORPORATED  
 CUSTOMER SERVICE SYSTEMS

FOR ADDITIONAL PRODUCT INFORMATION OR COPIES OF DRAWINGS AND TECHNICAL DOCUMENTS  
 FOR APPLICATION TOOLING INFORMATION  
 FOR ORDER ENTRY

PRODUCT INFORMATION CENTER  
 1-800-522-6752

TOOLING ASSISTANCE CENTER  
 1-800-722-1111

1-800-526-5142

MAX RECOMMENDED OPERATING TEMPERATURE: 170°C MAX

VOLTAGE RATING: NOT APPLICABLE

WIRE CROSS SECTIONAL AREA RANGE: 0.26-1.65mm<sup>2</sup> [509-3,260] CIR MILS STRANDED

DO NOT SCALE PRINT. UNLESS SPECIFIED OTHERWISE DIMENSIONS IN MILLIMETERS. TOLERANCES ON: 1. ANGLES 2. PLC DEC 3. PLC DEC

MATERIAL: COPPER PER ASTM B-152 ANNEALED

FINISH: TIN PLATE 0.00254L [0.00100] MIN THK PER MIL-T-10727

DR 3-2-93 TA BRINKMAN	NAME	<b>AMP</b> AMP Incorporated Harrisburg, PA 17105-3508
CHK 3-2-93 DA PATTERSON	PRODUCT SPEC	TERMINAL, FLANGED SPADE, BUDGET
APPD 3-2-93 DE MILLER	APPLICATION SPEC	SIZE CAGE CODE DRAWING NO C 00779 C-322776
APPD 3-2-93 JL NECKLEY	WEIGHT	SCALE 10:1 SHEET 1 OF 1