

Customer Information Sheet

DRAWING No.: H2088-01

SHEET 2 OF 2

IF IN DOUBT - ASK

©

NOT TO SCALE

THIRD ANGLE PROJECTION

ALL DIMENSIONS IN mm

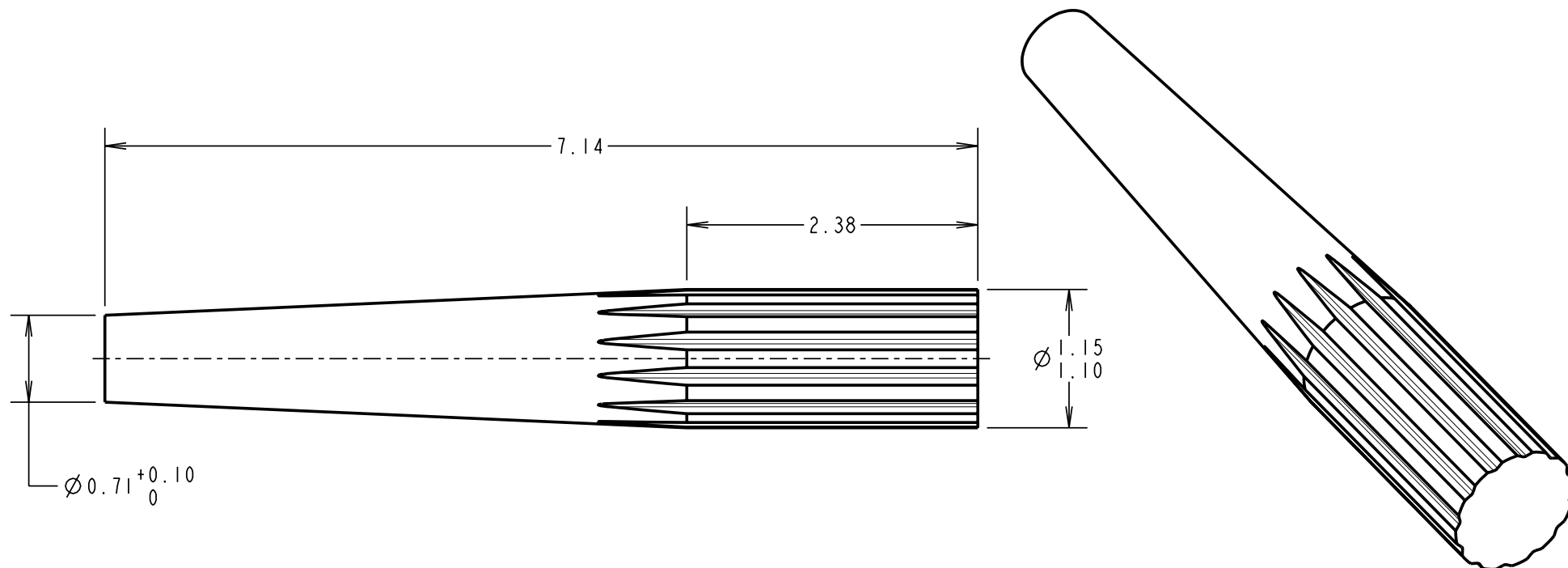

NOTES:

1. RECOMMENDED PANEL THICKNESS = 1.6/2.4mm.
2. RECOMMENDED MOUNTING HOLE SIZE FOR PAPER-BASED PANEL = $\varnothing 1.00$
RECOMMENDED MOUNTING HOLE SIZE FOR EPOXY-GLASS PANEL = $\varnothing 1.05$
3. PUNCH & DIE TOOL PART No. = Z2088-00

MGP	15	13.02.07	9697
NAME	ISS.	DATE	C/NOTE
APPROVED: MGP			
CHECKED: NJBC			
DRAWN: PETER COLLINS			
CUSTOMER REF.:			
ASSEMBLY DRG:			

HARWIN

THIS DRAWING AND ANY INFORMATION OR DESCRIPTIVE MATTER SET OUT HEREON ARE CONFIDENTIAL AND COPYRIGHT PROPERTY OF THE HARWIN GROUP AND MUST NOT BE DISCLOSED, LOANED, COPIED OR USED FOR MANUFACTURING, TENDERING OR FOR ANY OTHER PURPOSE WITHOUT THEIR WRITTEN PERMISSION.

TOLERANCES
X. = ± 1 mm
X.X = ± 0.25 mm
X.XX = ± 0.10 mm
X.XXX = ± 0.01 mm
ANGLES = $\pm 5^\circ$
UNLESS STATED

MATERIAL:
BRASS CW614N M
TO BS EN 12164 (CuZn39Pb3)
FINISH: 100% TIN OVER NICKEL
S/AREA: mm²

TITLE:
TERMINAL PIN
DRAWING NUMBER:
H2088-01

HARWIN USA
TEL: 603 893 5376
FAX: 603 893 5396
mis@harwin.com

HARWIN Europe (UK)
TEL: 023 9231 4545
FAX: 023 9231 4590
mis@harwin.co.uk

HARWIN Asia
TEL: +65 6 779 4909
FAX: +65 6 779 3868
mis@harwin.com.sg

SHT
2 OF 2