

INTRODUCTION:

Adam Tech Right Angle .318" footprint PCB D-Sub connectors are a popular interface for many I/O applications. Offered in 9, 15, 25 and 37 positions they are a good choice for a low cost industry standard connection. These connectors are manufactured with precision stamped contacts offering a choice of contact plating and a wide selection of mating and mounting options.

FEATURES:

Industry standard compatibility
Durable metal shell design
Precision formed bifurcated contacts
Variety of Mating and mounting options

MATING CONNECTORS:

Adam Tech D-Subminiatures and all industry standard D-Subminiature connectors.

SPECIFICATIONS:

Material:

Insulator: PBT, 30% glass reinforced, rated UL94V-0
Insulator color: Black
Contacts: Phosphor Bronze
Shell: Steel, Tin or Zinc plated
Hardware: Brass, Nickel plated

Contact Plating:

Gold Flash (15 and 30 μ in Optional) over Nickel underplate.

Electrical:

Operating voltage: 250V AC / DC max.
Current rating: 5 Amps max.
Contact resistance: 20 m Ω max. initial
Insulation resistance: 5000 M Ω min.
Dielectric withstanding voltage: 1000V AC for 1 minute

Mechanical:

Insertion force: 0.75 lbs max
Extraction force: 0.44 lbs min

Temperature Rating:

Operating temperature: -65°C to +125°C

PACKAGING:

Anti-ESD plastic trays

APPROVALS AND CERTIFICATIONS:

UL Recognized File No. E224053
CSA Certified File No. LR1578596

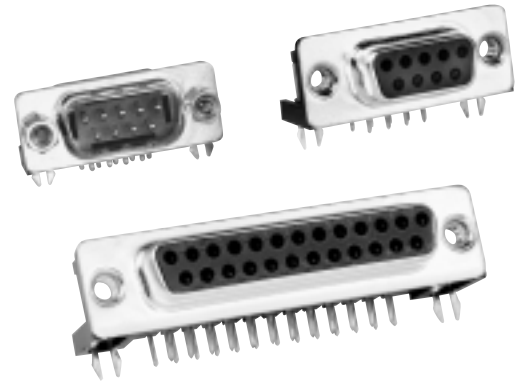
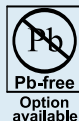

ORDERING INFORMATION

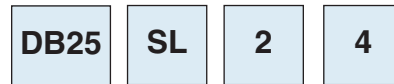

SHELL SIZE/ POSITIONS

DE09 = 9 Position
DA15 = 15 Position
DB25 = 25 Position
DC37 = 37 Position

CONTACT TYPE

PL = Plug, .318"
Footprint
SL = Socket, .318"
Footprint

MATING FACE MOUNTING OPTIONS

3 = #4-40 jackscrews
4 = #4-40 flush threaded
inserts
5 = #4-40 flush threaded
inserts with removable
jackscrews installed
6 = .120" non-threaded
mounting holes

BOARD MOUNTING OPTIONS

1 = Wrap around ground
straps with holes
2 = Forked board locks
3 = Top side only ground
straps with holes
4 = Top side only ground
straps with #4-40
threaded screw holes



OPTIONS:

Add designator(s) to end of part number
30 = 30 μ in gold plating in contact area
EMI = Ferrite filtered version for EMI/RFI suppression
LPJ = Loose packed jackscrews
F = Superior retention 4 prong boardlocks
HT = Hi-Temp insulator for Hi-Temp soldering processes
R = Round jackscrews
RC = RoHS compliant lead-free product with Hi-Temp insulator
PF = Press fit pins

PLUG

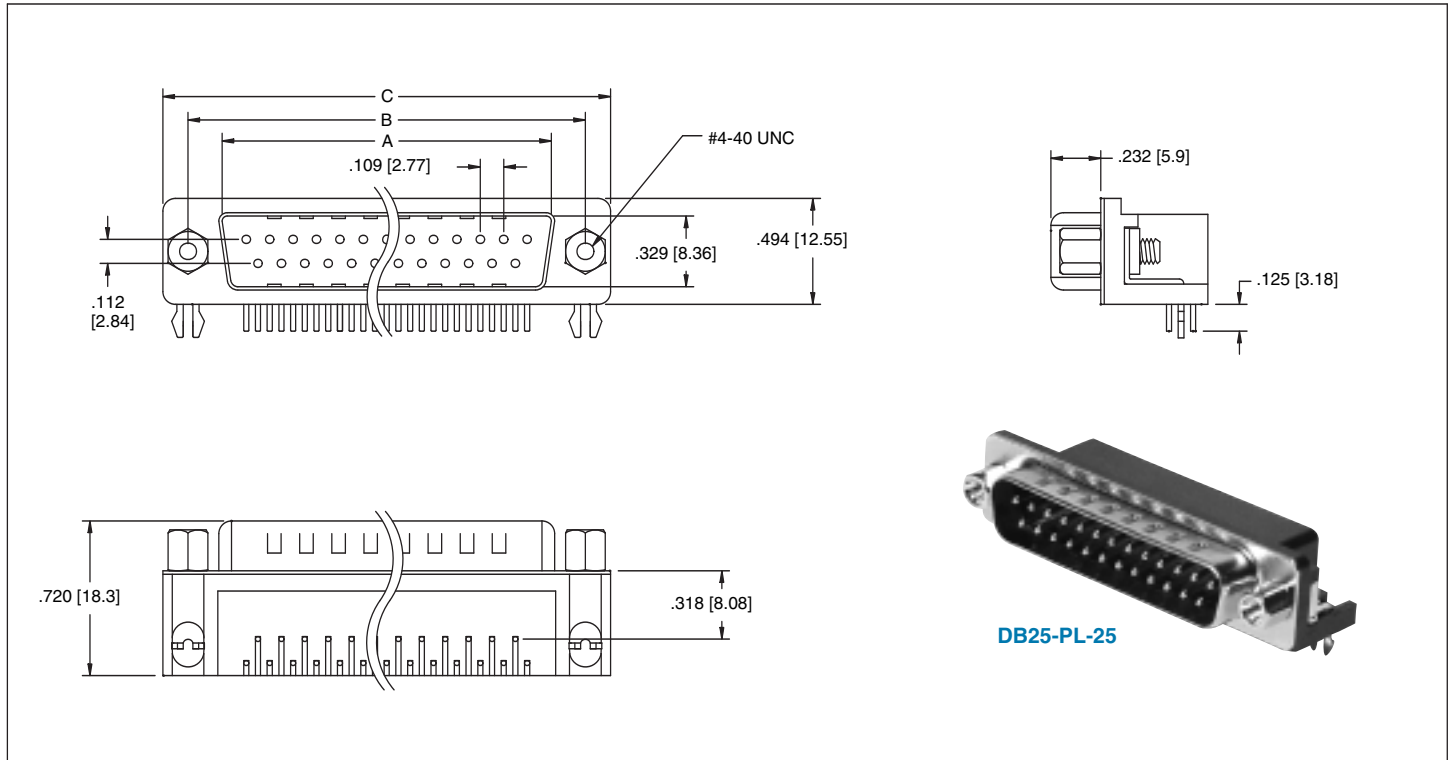

SOCKET

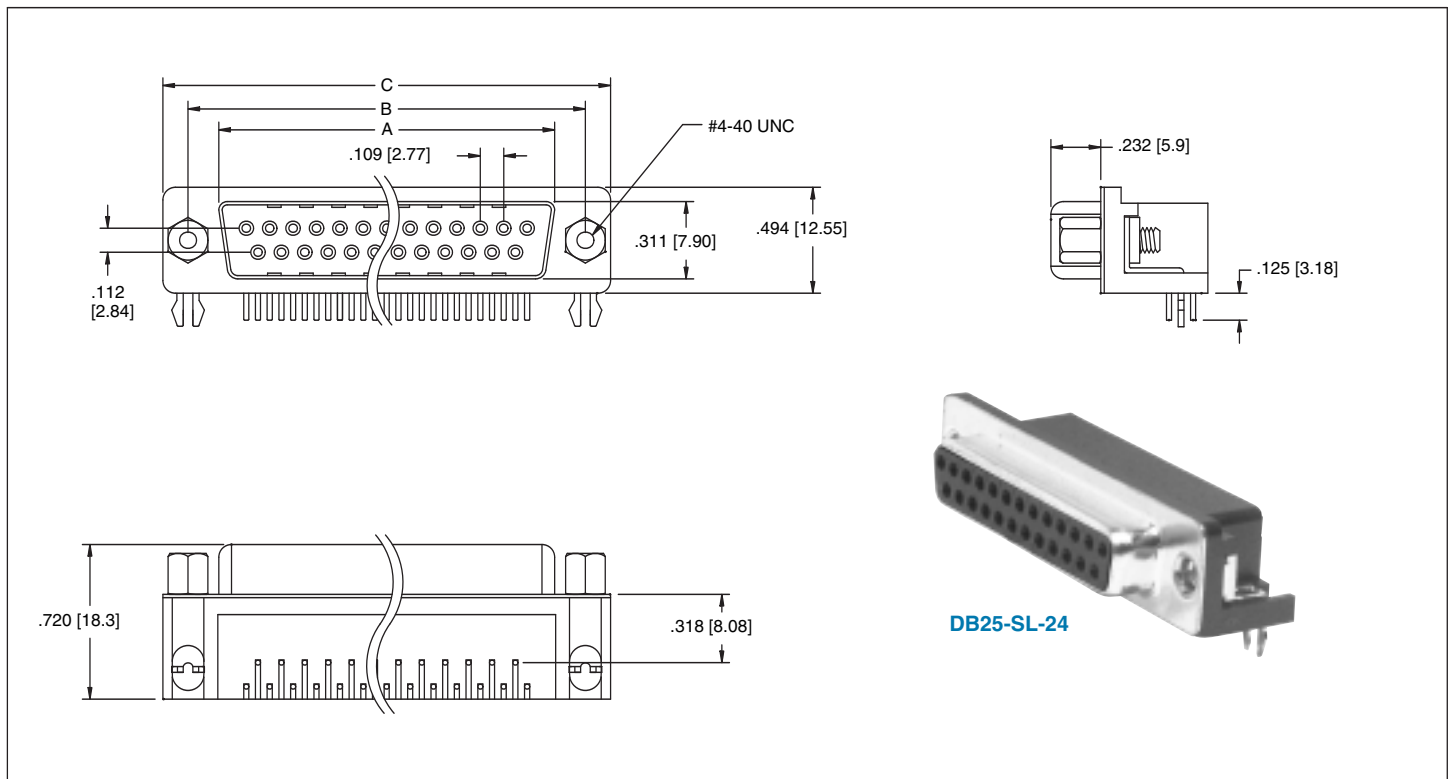

MATING FACE MOUNTING OPTIONS

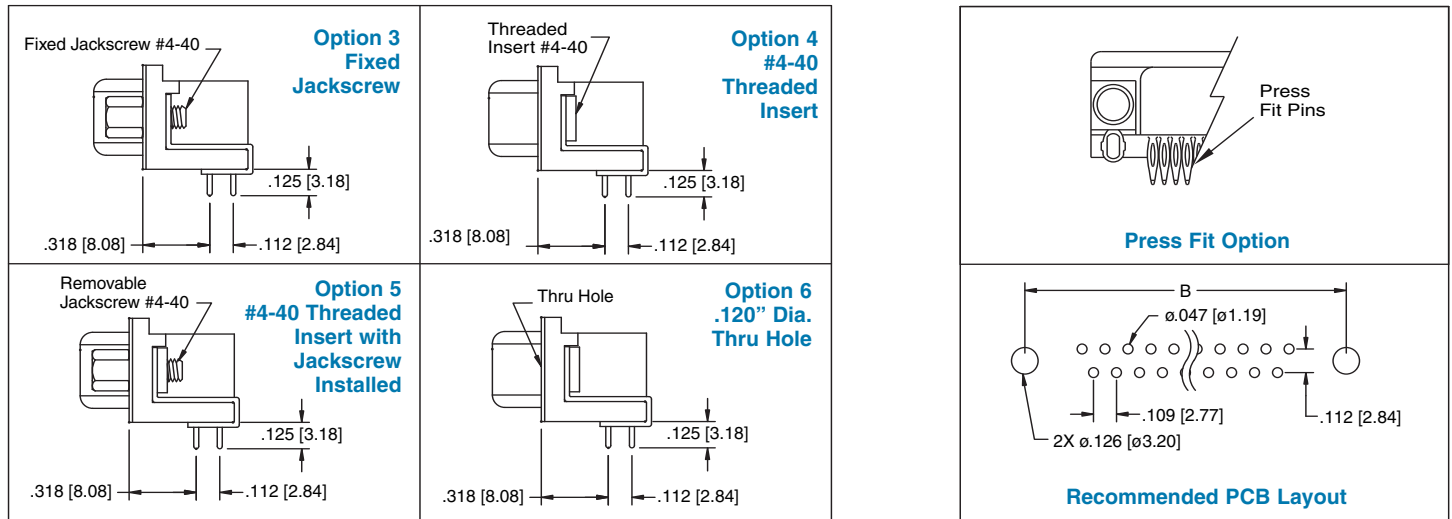

PC BOARD MOUNTING OPTIONS

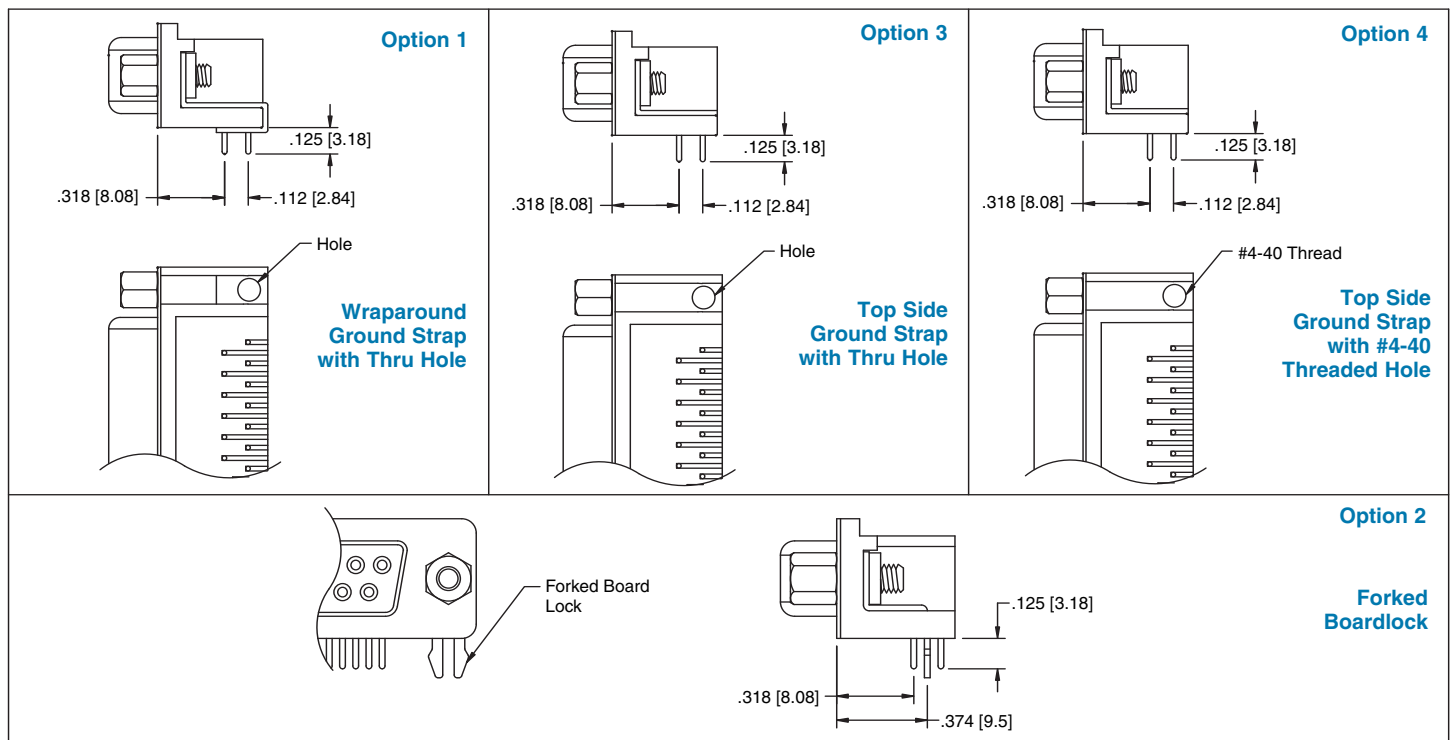

Unit: Inch / mm

POSITIONS	Socket Dimensions			POSITIONS	Plug Dimensions		
	A	B	C		A	B	C
9	.643 (16.33)	.984 (24.99)	1.213 (30.81)	9	.666 (16.92)	.984 (24.99)	1.213 (30.81)
15	.971 (24.66)	1.312 (33.32)	1.541 (39.14)	15	.994 (25.25)	1.312 (33.32)	1.541 (39.14)
25	1.511 (38.38)	1.852 (47.04)	2.088 (53.04)	25	1.534 (38.96)	1.852 (47.04)	2.088 (53.04)
37	2.159 (54.84)	2.500 (63.50)	2.729 (69.32)	37	2.182 (55.42)	2.500 (63.50)	2.729 (69.32)