

NOTES:

1. MATERIALS AND FINISHES:
 BODY, FERRULE AND BAYONET SLEEVE - BRASS, NICKEL PLATING
 OUTER CONTACT - BeCu, NICKEL PLATING
 CONTACT - PHOSPHOR BRONZE, GOLD PLATING
 INSULATOR - PTFE, NAUTRAL
2. ELECTRICAL:
 A. IMPEDANCE: 75 OHM
 B. FREQUENCY RANGE: DC - 3 GHz
 C. RETURN LOSS: 30 dB MIN @ 3 GHz
 D. DIELECTRIC WITHSTANDING VOLTAGE: 1000 VRMS, MIN.
 E. INSULATION RESISTANCE: 10,000 MΩ MIN
3. MECHANICAL:
 A. DURABILITY: 500 CYCLES MIN.
 B. TEMPERATURE RANGE: -65° C TO +165° C
4. ENVIRONMENTAL:
 A. THERMAL SHOCK PER MIL-STD-202 METHOD 107
 TEST CONDITION B (EXCEPT HIGH TEMP @200°C)
 B. VIBRATION: MIL-STD-202 METHOD 204 TEST CONDITION B
 C. SHOCK: MIL-STD-202 METHOD 213 TEST CONDITION B
 D. CORROSION: MIL-STD-202 METHOD 101
 TEST CONDITION B 5% SALT SOLUTION
5. PACKAGING:
 A. QUANTITY: SINGLE PACK
 B. MARKING: BAG TO BE MARKED:
 "AMPHENOL RF, 34-1017-300 DATE CODE
 U.S. PATENT NO. 7,553,177"
6. HIGH DENSITY INSTALLATION/REMOVAL TOOL: 227-T2000-1694A.
7. CABLE ASSEMBLY INSTRUCTIONS:
 A. TRIM CABLE AS SHOWN.
 B. CRIMP CONTACT TO CABLE CENTER CONDUCTOR
 WITH .042" SQUARE DIE
 C. CRIMP FERRULE WITH .278" INCH HEX

8 SHOWS CABLE ENTRY DIMENSIONS.

INTERFACE PER
 349-50820
 SERIES : HD-BNC PLUG

THIRD ANGLE PROJ.

REVISIONS

REV	DESCRIPTION	DATE	ECO	APPR
A	RELEASED TO MFG	02-Jun-10	48161	TD
B	NOTE 5-B WAS CHANGED	23-Feb-11	48437	SH
C	COUPLING MECHANISM UPDATED	20-Aug-12	49196	SH

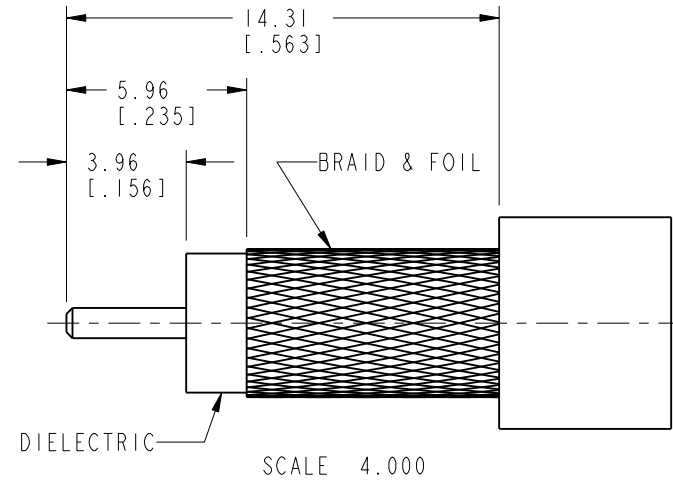

RECOMMENDED CABLE STRIPPING DIMENSIONS

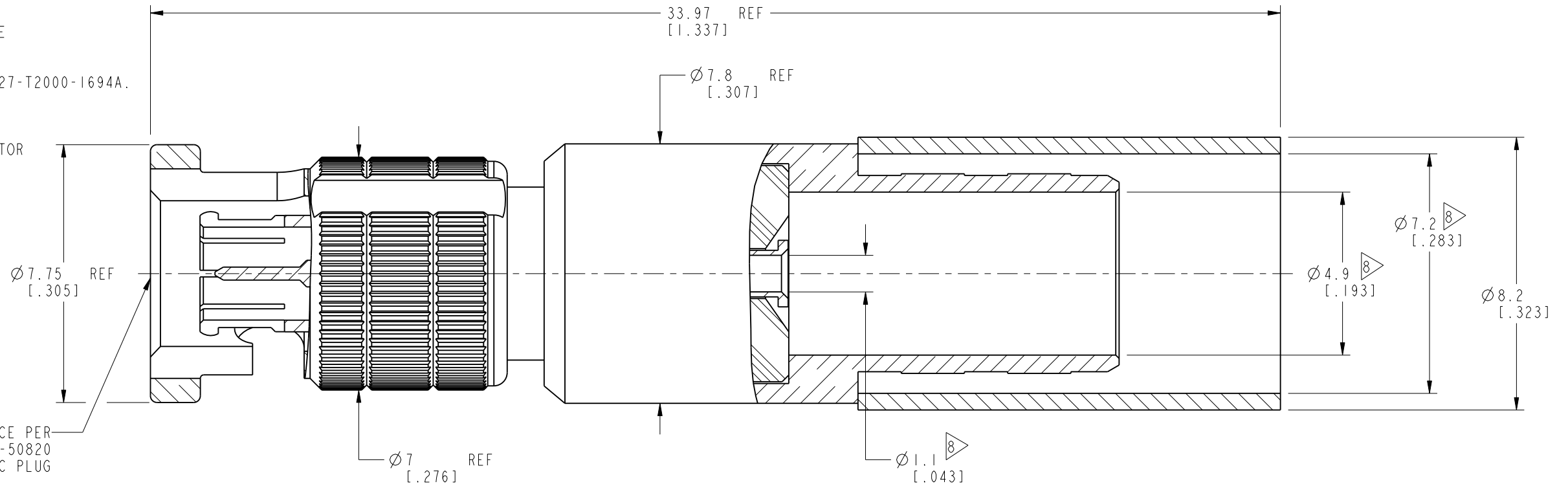
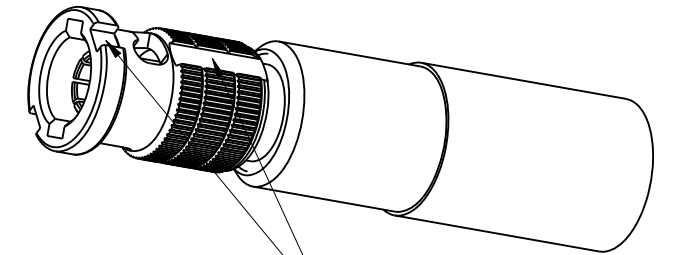

PROTECTED UNDER U.S. PATENT # 7,553,177

CUSTOMER OUTLINE DRAWING

ALL OTHER SHEETS ARE FOR INTERNAL USE ONLY

UNLESS OTHERWISE SPECIFIED, DIMENSIONS ARE IN METRIC AND TOLERANCES ARE: <0.5mm ±0.05mm 0.5 - 6mm ±0.1mm 6 - 30mm ±0.2mm 30 - 120mm ±0.3mm ANGLES ±1°	MATERIAL	DRAWN T. DENG	DATE 20-Aug-12	TITLE HD-BNC STR PLUG FOR 1694A 9.50 MM PITCH	Amphenol RF Danbury CT USA, Tainan, Taiwan, Shenzhen, China www.amphenolrf.com
	REFERENCE EAR # 3897	ENGINEER A ARUN PRABU	DATE 10-Mar-10		
	CONFIGURATION LEVEL:	APPROVED S. HSIEH	DATE 20-Aug-12	SHEET 2 OF 2	ITEM NO. 34-1017-300
	FINISH	CAD FILE	DWG SIZE B	REV C	PART NO. 34-1017-300

NOTICE - These drawings, specifications, or other data (1) are, and remain the property of Amphenol corp. (2) must be returned upon request; and (3) are confidential and not to be disclosed to any person other than those to whom they are given by Amphenol Corp. the finishing of these drawings, specifications, or other data by Amphenol Corp., or to any other person to anyone for any purpose is not to be regarded by implication or otherwise in any manner licensing, granting rights to permitting such holder or any other person to manufacture, use or sell any product, process or design, patented or otherwise, that may in any way be related to or disclosed by said drawings, specifications, or other data.

ASSEMBLY INSTRUCTIONS

AmphenolRF

HD - BNC CRIMP PLUGS

REV - 1

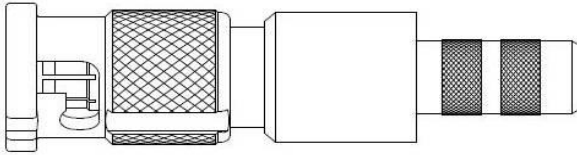

PLUG BODY ASSEMBLY



MALE CONTACT



OUTER FERRULE

AMPHENOL NUMBER	CABLE	HEX CRIMP DATA			STRIPPING DIMENSIONS, INCHES (MM)		
		CAVITY FOR CONTACT	CAVITY FOR OUTER FERRULE	CTL SERIES TOOL NUMBER	A	B	C
34-1026	1855A, T8550A	0.042 (1.1) □	0.178 (4.6) ◊	CTL-15	0.156 (3.96)	0.233 (5.92)	0.562 (14.27)
34-1037	1855ENH, 0.6/2.8	0.042 (1.1) □	0.197 (5.0) ◊	-	0.156 (3.96)	0.250 (6.35)	0.594 (15.09)
34-1037-100	1855ENH, IMAGE 360, 1.0/4.8	0.042 (1.1) □	0.197 (5.0) ◊	-	0.156 (3.96)	0.250 (6.35)	0.594 (15.09)
34-1033	TFC HD 210	0.042 (1.1) □	0.213 (5.4) ◊	-	0.156 (3.96)	0.233 (5.92)	0.562 (14.27)
34-1027	1695A	0.042 (1.1) □	0.255 (6.5) ◊	CTL-14	0.156 (3.96)	0.235 (5.97)	0.564 (14.33)
34-1025	1505A, T5050A, IMAGE 720, 0.8/3.7	0.042 (1.1) □	0.255 (6.5) ◊	CTL-14	0.156 (3.96)	0.235 (5.97)	0.564 (14.33)
34-1017-300	1694A, T6940A, IMAGE 1000	0.042 (1.1) □	0.278 (7.1) ◊	-	0.156 (3.96)	0.235 (5.97)	0.564 (14.33)

STEP 1

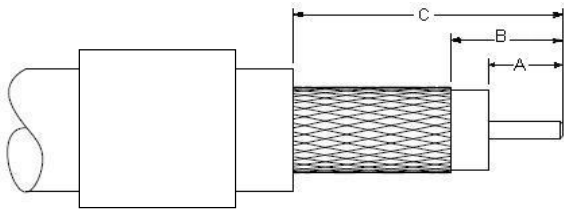

Step 1 - Strip cable jacket, braid, and dielectric to dimensions in table above. All cuts are to be sharp and square. Important : Do not nick braid dielectric and center conductor. Slide outer ferrule onto cable as shown.

STEP 2

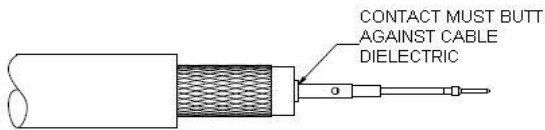

Step 2 - Flare slightly end of cable braid to facilitate insertion of inner ferrule. Place contact on cable center conductor so that it butts against cable dielectric. Crimp contact in place using die set cavity indicated in table above.

STEP 3

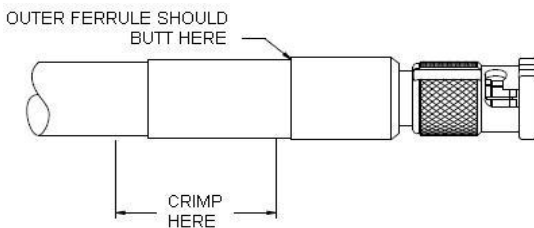

Step 3 - Install cable assembly into body assembly so that inner ferrule portion slides under braid. Push cable assembly forward until contact snaps into place in insulator. Slide outer ferrule over braid and up against connector body. Crimp outer ferrule using die set cavity specified in table above.

Use tool 227-T2000 (1 ft long) or 227-T2000-2FT (2 ft long) for installation and removal of the HD-BNC plug.