

NOTES:

1. MATERIALS AND FINISHES:
 BODY - NICKEL PLATED ZINC DIE CAST
 INSULATOR - WHITE NORYL
 CENTER CONTACT - GOLD PLATED PHOSPHOR BRONZE
 MOUNTING PINS - BRIGHT TIN PLATED BRASS
 TERMINALS - TIN PLATED COPPER WIRE
2. ACCOMMODATES UP TO .125 THICK PC BOARD AND .188 PANEL THICKNESS.
3. DIELECTRIC WITHSTANDING VOLTAGE: 1500VRMS MAX.
4. INSULATION RESISTANCE: 5000MΩ MIN.
5. NOMINAL IMPEDANCE: 50 OHMS.
6. DO NOT SCALE THIS DRAWING.
7. UNLESS OTHERWISE SPECIFIED, ALL DIMENSIONS ARE AFTER PLATING.

31-5633-1010		REVISIONS			
DRAWING NO.	REV	DESCRIPTION	DATE	ECO	APPR
THIRD ANGLE PROJ.	A	OFFICIAL ENG. RELEASE TO MFG.	12/10/92	39213	JM/DR
	C	SEE SHEET 1 FOR REVISIONS	4/26/96	41291	CPM/
	D	SEE SHEET 1 FOR REVISIONS	2/3/05	45255	CPM/

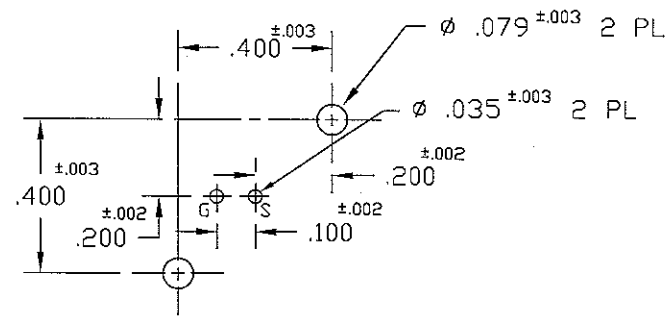

PC HOLE MOUNTING

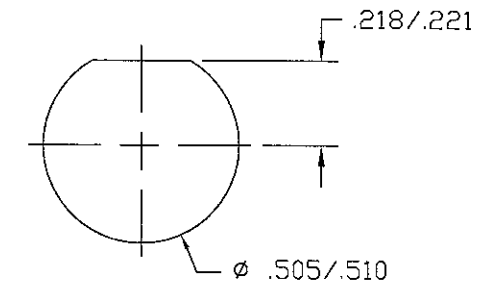
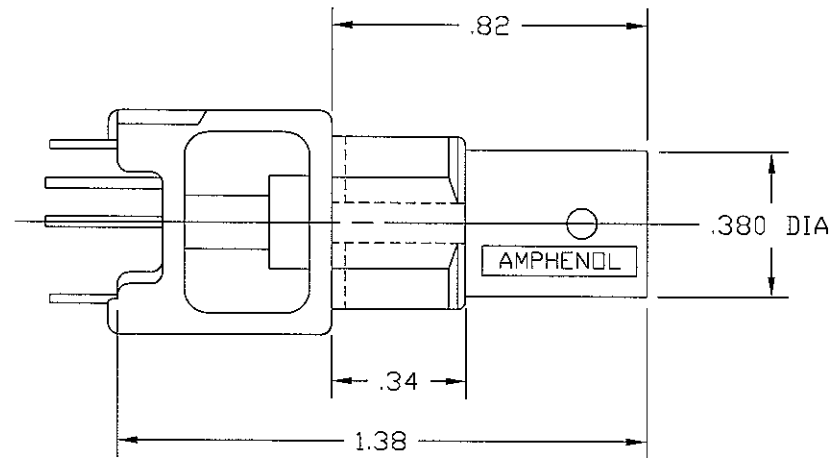

PANEL CUT-OUT

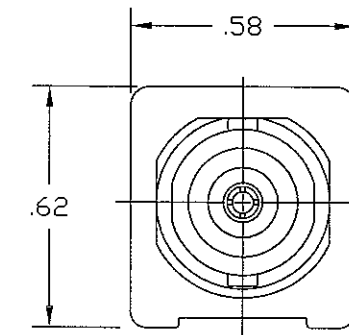
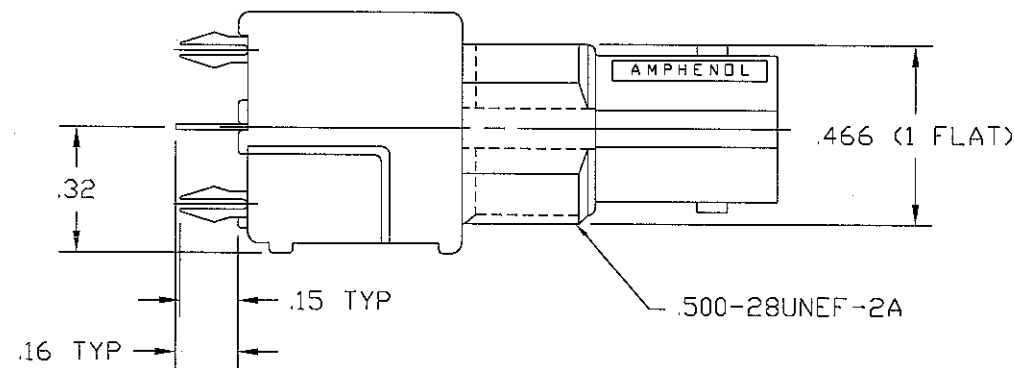
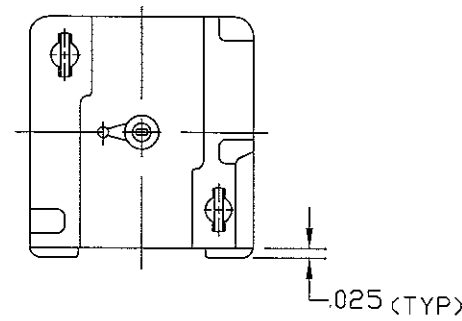

CUSTOMER OUTLINE DWG.

UNLESS OTHERWISE SPECIFIED, DIMENSIONS ARE IN INCHES AND TOLERANCES ARE: 2 PLACE DECIMAL ±.015 (0,381 mm) 3 PLACE DECIMAL ±.005 (0,127 mm) ANGLES ± 1°	MATERIAL	DRAWN J. MULVEY	DATE 8/26/92	TITLE BNC JACK VERT. PCB MOUNT ZINC DIE CAST		Amphenol Amphenol Corporation RF/Microwave Operations Danbury, Conn. U.S.A. 06810	
	REFERENCE EAR 962338-2	ENGINEER R. VACCARD	DATE 12/6/92				
NOTICE - These drawings, specifications, or other data (1) are, and remain the property of Amphenol Corp. (2) must be returned upon request; and (3) are confidential and not to be disclosed to any person other than those to whom they are given by Amphenol Corp. The furnishing of these drawings, specifications, or other data by Amphenol Corp., or to any other person to anyone for any purpose is not to be regarded by implication or otherwise in any manner licensing, granting rights or permitting such holder or any other person to manufacture, use or sell any product, process or design, patented or otherwise, that may in any way be related to or disclosed by said drawings, specifications, or other data.		APPROVED J. MULVEY	DATE 8/26/92	SCALE: 2:1	SHEET 2 OF 2		ISSUE D
		CAD FILE H:\DEPT611\BNC\031\ASSY\5633\1010SH2.DWG	CODE ID 74868	DWG SIZE B	DRAWING NO. 31-5633-1010		