

NOTES:

- MATERIALS AND FINISHES:
 - BODY, REAR BODY - BRASS, NICKEL PLATING
 - CONTACT - BERYLLIUM COPPER, GOLD PLATING.
 - INSULATOR - PTFE
 - INSULATOR REAR - ULTEM
 - HEX NUT - BRASS, NICKEL PLATING
 - LOCK WASHER - BRASS, NICKEL PLATING
 - GASKET, O-RING - SILICONE RUBBER
 - FERRULE - SEAMLESS COPPER TUBE, NICKEL PLATING
 - HEAT SHRINK TUBING - CROSSLINKED POLYOLEFIN

- ELECTRICAL:
 - A. IMPEDANCE: 50 OHM
 - B. FREQUENCY RANGE: DC - 6 GHz
 - C. DIELECTRIC WITHSTANDING VOLTAGE: 1000 VRMS, MIN.

- MECHANICAL:
 - A. DURABILITY: 500 CYCLES MIN.
 - B. TEMPERATURE RANGE: -65° C TO +85° C

- PACKAGING:
 - A. QUANTITY: SINGLE PACK
 - B. MARKING: BAG TO BE MARKED "AMPHENOLRF, 31-6368, AND DATE CODE"

- RECOMMENDED CABLE ASSEMBLY INSTRUCTIONS:
 - A. TRIM CABLE AS SHOWN.
 - B. SLIDE HEAT SHRINK TUBING, FERRULE AND INSULATOR REAR ONTO CABLE.
 - C. SOLDER CABLE CENTER CONDUCTOR TO CONTACT.
 - D. INSERT CABLE WITH FOIL ENTERING CONNECTOR AND BRAID OVER KNURL.
 - E. CRIMP FERRULE OVER BRAID WITH 0.213" HEX DIE.
 - F. APPLY HEAT SHRINK TUBING OVER FERRULE.
 - G. HEAT SHRINK TUBING SHOULD FULLY (360 DEG) COVER THE BUMP ON BODY AND END WITHIN AREA "A"

- CAP ASSEMBLY INSTRUCTIONS:
 - A. PLACE O-RING ON CAP AS SHOWN.
 - B. ASSEMBLE CAP TO BODY WITH 6-10 IN-LBS TORQUE.

- RECOMMENDED TORQUE APPLIED ON HEX NUT: 7-10 IN-LBS.

- SHOWS CABLE ENTRY DIMENSIONS.

THIRD ANGLE PROJ.

REVISIONS

REV	DESCRIPTION	DATE	ECO	APPR
A	RELEASE TO MFG.	29-Mar-12	48952	DD

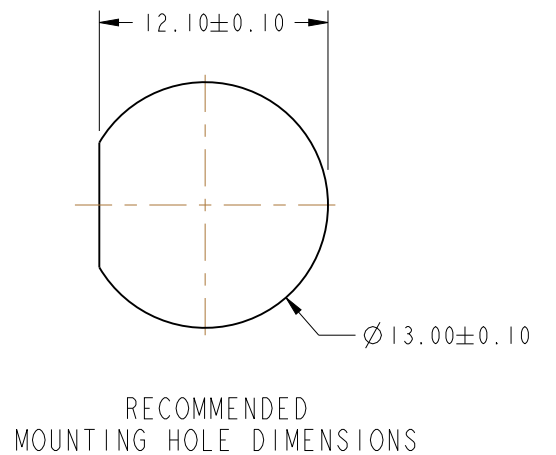
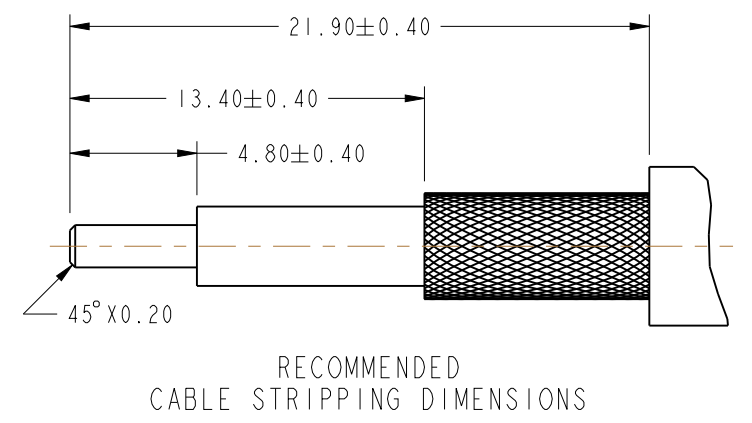
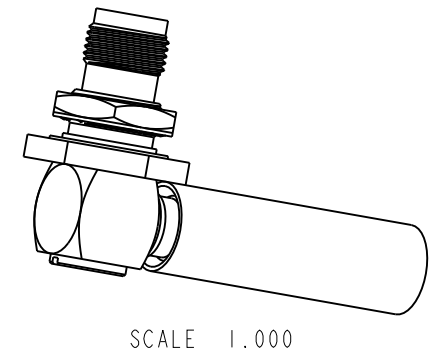
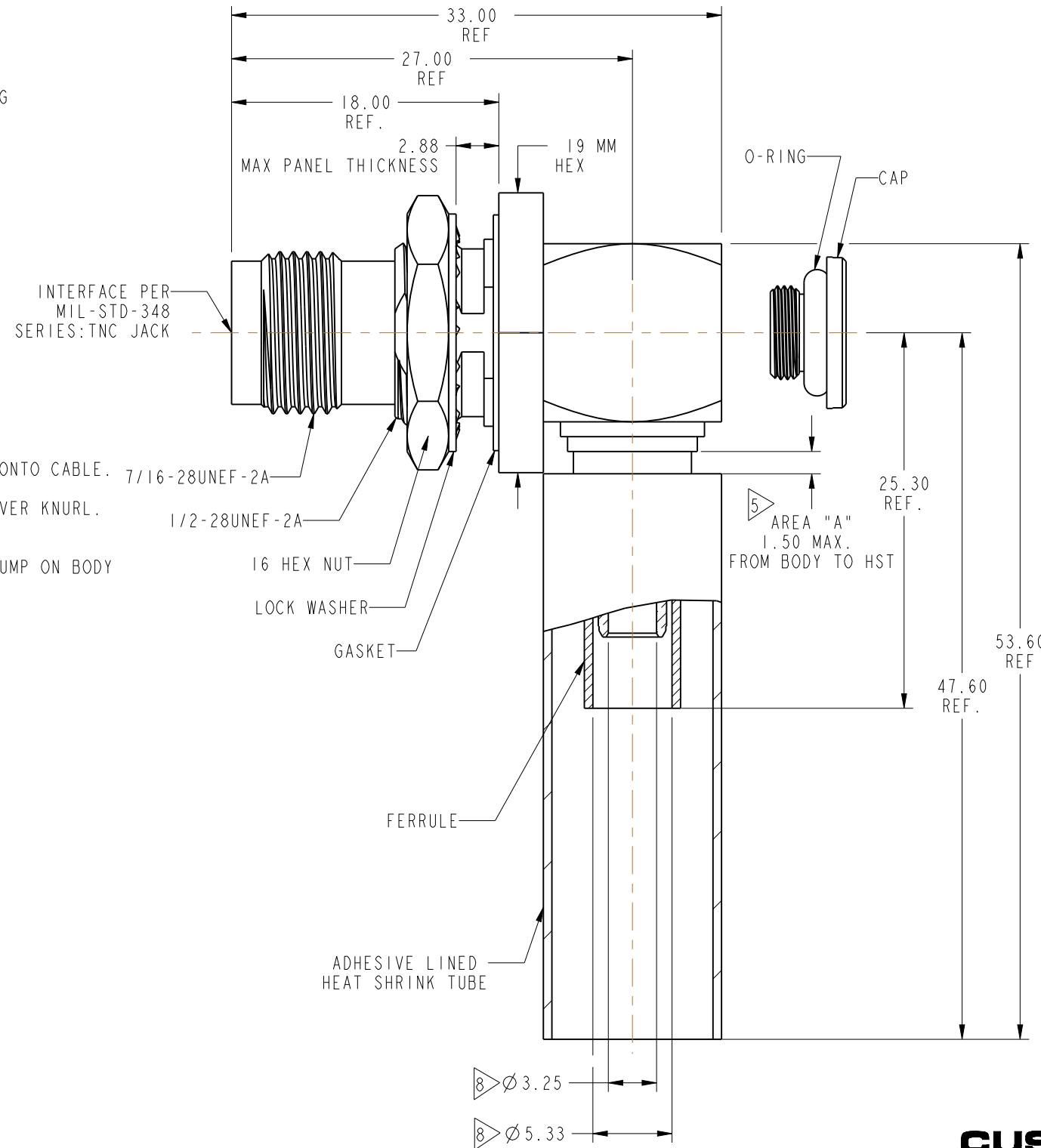

CUSTOMER OUTLINE DRAWING
ALL OTHER SHEETS ARE FOR INTERNAL USE ONLY

UNLESS OTHERWISE SPECIFIED, DIMENSIONS ARE IN METRIC AND TOLERANCES ARE: 0.5 - 6mm ±0.1mm 6 - 30mm ±0.2mm 30 - 120mm ± 0.3mm ANGLES ±1°	MATERIAL	DRAWN	DATE	TITLE TNC R/A BHD JACK IP-67 FOR LMR 200 CABLE		Amphenol RF Danbury CT USA, Tainan, Taiwan, Shenzhen, China www.amphenolrf.com	
	SEE NOTES	D.DAVE	08-Sept-11				
NOTICE - These drawings, specifications, or other data (1) are, and remain the property of Amphenol corp. (2) must be returned upon request; and (3) are confidential and not to be disclosed to any person other than those to whom they are given by Amphenol Corp. the furnishing of these drawings, specifications, or other data by Amphenol Corp., or to any other person to anyone for any purpose is not to be regarded by implication or otherwise in any manner licensing, granting rights to permitting such holder or any other sperson to manufacture, use or sell any product, process or design, patented or otherwise, that may in any way be related to or disclosed by said drawings, specifications, or other data.	REFERENCE	ENGINEER	DATE	SCALE: 2.6:1.0 SHEET 2 OF 2		DRAWING NO. 31-6509 ITEM NO. 31-6509	
		D.DAVE	08-Sept-11				
	CONFIGURATION LEVEL: <input type="checkbox"/> <input type="checkbox"/> <input type="checkbox"/>	APPROVED	DATE		DWG SIZE	CODE ID	REV
FINISH	Root Folder/TNC/31-6509			B	74868	A	