

NOTES:

1. MATERIALS AND FINISHES:
 OUTER CONTACT- PHOSPHOR BRONZE, NICKEL PLATING (.0001 THICK)
 FRONT BODY - ZINC ALLOY, NICKEL PLATING (.00015 THICK)
 CRIMP CONTACT - BRASS, GOLD PLATING (.00005 THICK)
 INSULATOR - PTFE
2. ELECTRICAL:
 A. IMPEDANCE: 75 OHM
 B. FREQUENCY RANGE: DC - 3 GHz
 C. VSWR(RETURN LOSS): 1.10 UP TO 2 GHz(-26.44 dB), 1.16 UP TO 3 GHz(-22.61 dB)
 D. DIELECTRIC WITHSTANDING VOLTAGE: 1500 VRMS, MIN.
 E. WORKING VOLTAGE: 500 VAC PEAK
3. MECHANICAL:
 A. DURABILITY: 500 CYCLES MIN.
 B. TEMPERATURE RANGE: -40° C TO +85° C
4. PACKAGING:
 A. QUANTITY: SINGLE PACK
 B. MARKING: BAG TO BE MARKED
 "AMPHENOL, PN:5, AND DATE CODE"
5. FOR CABLE STRIPPING AND ASSEMBLY INSTRUCTIONS SEE AMPHENOL SPEC 349-50756.
 FERRULE TO BE CRIMPED WITH A .255 HEX DIE.
 CONTACT TO BE CRIMPED WITH A .042 SQUARE DIE
 OR A 8 PT CRIMPER AMPHENOL NUMBER CTL-TI200

31-80904		REVISIONS			
DRAWING NO.	REV	DESCRIPTION	DATE	ECO	APPR
THIRD ANGLE PROJ.	A	RELEASE TO MFG.	8/17/06	46206	GSA
	B	NOTE 5 '8 PT CRIMPER AMPHENOL NUMBER CTL-TI200'	8/6/07	46681	TC

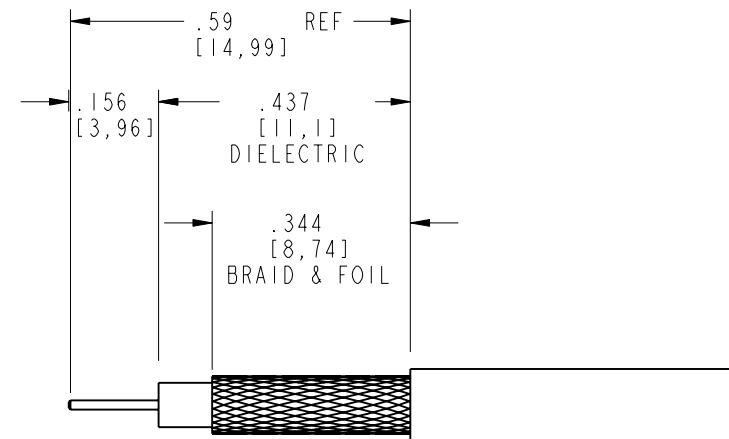
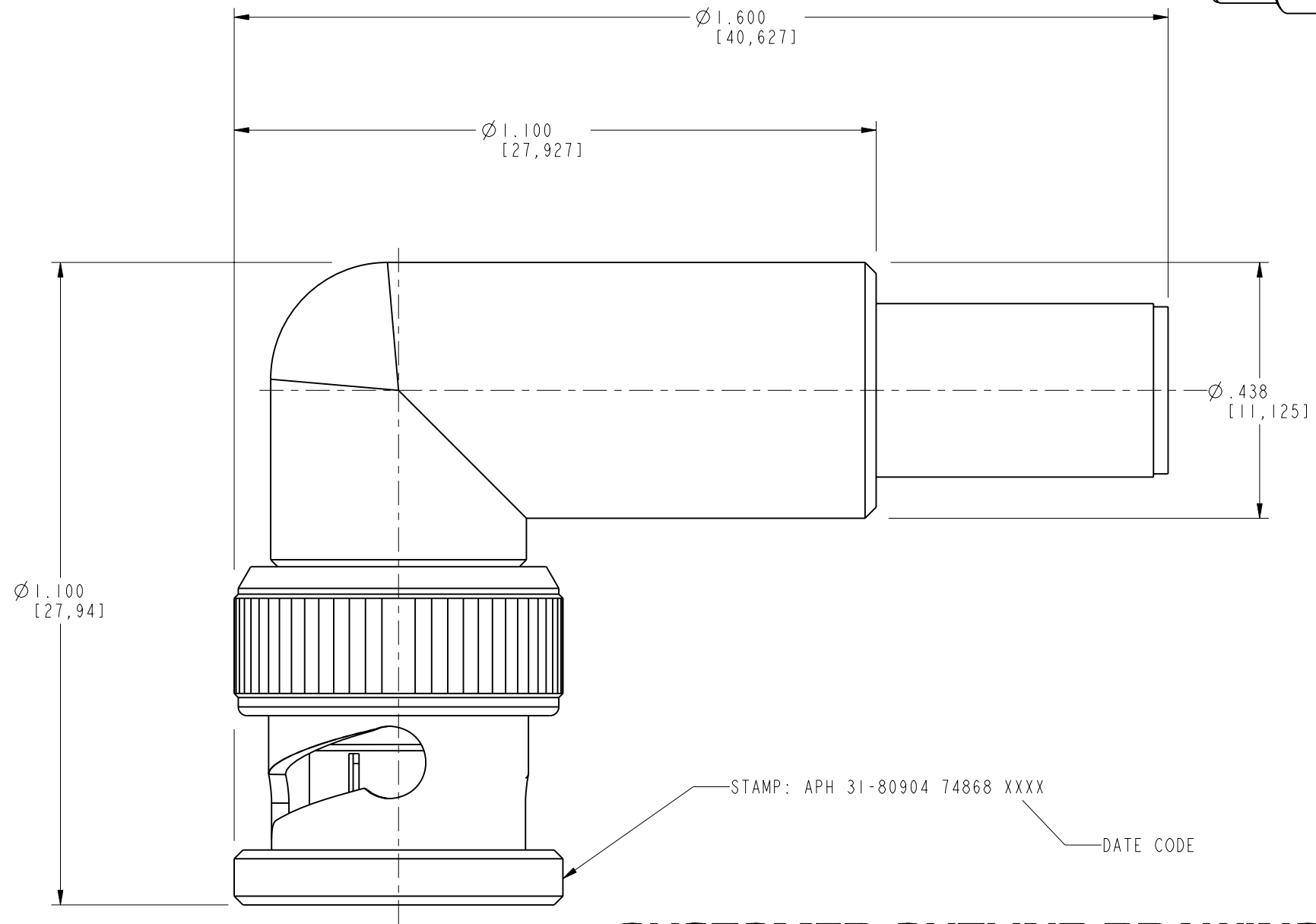
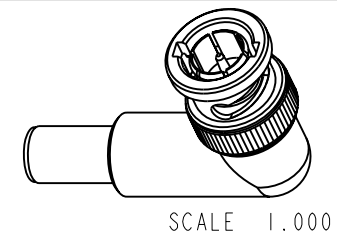

RECOMMENDED CABLE STRIPPING DIMENSIONS

SCALE 3.000

CUSTOMER OUTLINE DRAWING
 ALL OTHER SHEETS ARE FOR INTERNAL USE ONLY

UNLESS OTHERWISE SPECIFIED, DIMENSIONS ARE IN INCHES AND TOLERANCES ARE: 2 PLACE DECIMAL $\pm .015$ (0,381 mm) 3 PLACE DECIMAL $\pm .005$ (0,127 mm) ANGLES $\pm 1^\circ$	MATERIAL	DRAWN G. ANTONINI	DATE 29-Mar-05	TITLE BNC 90° ANGLE PLUG FOR AT&T 734 CABLE		Amphenol RF Danbury, CT, USA Tainan, Taiwan Shenzhen, China www.amphenolrf.com	
	REFERENCE	ENGINEER G. ANTONINI	DATE 29-Mar-05				
NOTICE - These drawings, specifications, or other data (1) are, and remain the property of Amphenol Corp. (2) must be returned upon request; and (3) are confidential and not to be disclosed to any person other than those to whom they are given by Amphenol Corp. The furnishing of these drawings, specifications, or other data by Amphenol Corp., or to any other person to anyone for any purpose is not to be regarded by implication or otherwise in any manner licensing, granting rights or permitting such holder or any other person to manufacture, use or sell any product, process or design, patented or otherwise, that may in any way be related to or disclosed by said drawings, specifications, or other data.		APPROVED O. BARTHELMES	DATE 8/17/06	CODE ID 74868	DWG SIZE B	DRAWING NO. 31-80904	SCALE: 4.0:1
		CAD FILE I:\BNC\31-80904					SHEET 2 OF 2
							REV B