

NOTES:

- MATERIALS AND FINISHES:
 BODY AND BAYONET SLEEVE - BRASS, NICKEL PLATING
 OUTER CONTACT - BeCu, NICKEL PLATING
 CONTACT - PHOSPHOR BRONZE, GOLD PLATING
 FERRULE - COPPER, NICKEL PLATING
 INSULATOR - PTFE
- ELECTRICAL:
 A. IMPEDANCE: 75 OHM
 B. FREQUENCY RANGE: DC - 3 GHz
 C. RETURN LOSS: 30 dB MIN @ 3 GHz
 D. DIELECTRIC WITHSTANDING VOLTAGE: 1000 VRMS, MIN.
 E. INSULATION RESISTANCE: 10,000 MΩ MIN
- MECHANICAL:
 A. DURABILITY: 500 CYCLES MIN.
 B. TEMPERATURE RANGE: -65° C TO +165° C
- ENVIRONMENTAL:
 A. THERMAL SHOCK PER MIL-STD-202 METHOD 107
 TEST CONDITION B (EXCEPT HIGH TEMP @200°C)
 B. VIBRATION: MIL-STD-202 METHOD 204 TEST CONDITION B
 C. SHOCK: MIL-STD-202 METHOD 213 TEST CONDITION B
 D. CORROSION: MIL-STD-202 METHOD 101
 TEST CONDITION B 5% SALT SOLUTION
- PACKAGING:
 A. QUANTITY: SINGLE PACK
 B. MARKING: BAG TO BE MARKED:
 "AMPHENOLRF, 34-1042 DATE CODE
 U.S. PATENT NO. 7,553,177"
- HIGH DENSITY INSTALLATION/REMOVAL TOOL: 227-T2000
- CABLE ASSEMBLY INSTRUCTIONS:
 A. TRIM CABLE AS SHOWN.
 B. SOLDER CONTACT TO CABLE CENTER CONDUCTOR
 C. CRIMP FERRULE WITH .128" HEX.

8 SHOWS CABLE ENTRY DIMENSIONS.

THIRD ANGLE PROJ.

REVISIONS

REV	DESCRIPTION	DATE	ECO	APPR
A	RELEASE TO MFG.	8/15/12	49135	MG

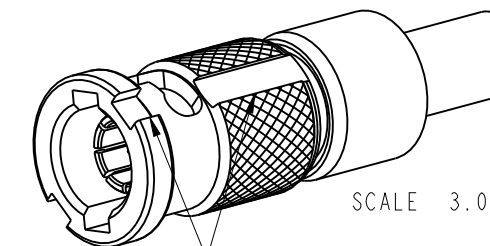
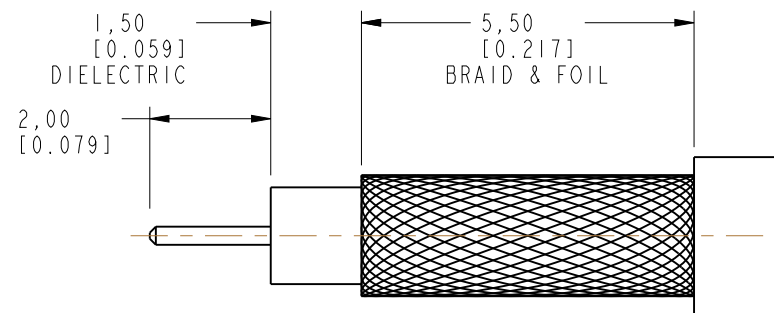

RECOMMENDED CABLE STRIPPING DIMENSIONS

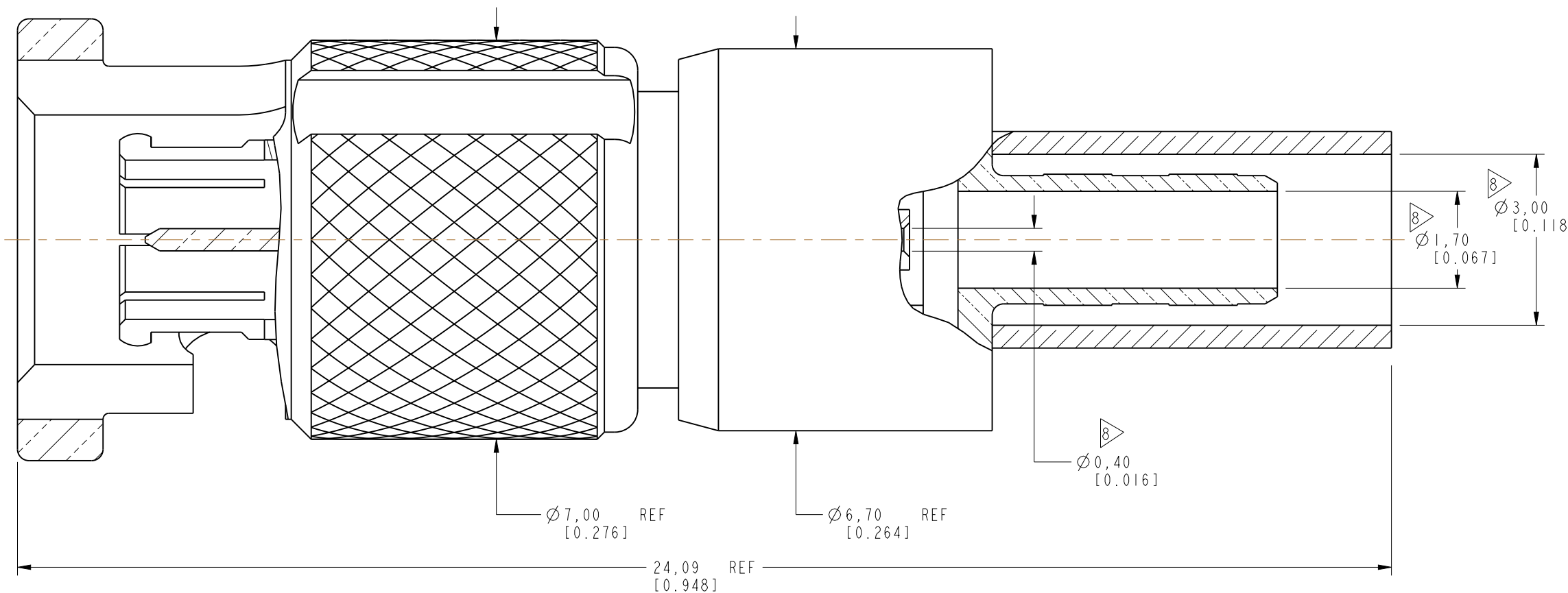

PROTECTED UNDER U.S. PATENT # 7,553,177

CUSTOMER OUTLINE DRAWING

ALL OTHER SHEETS ARE FOR INTERNAL USE ONLY

UNLESS OTHERWISE SPECIFIED, DIMENSIONS ARE IN METRIC AND TOLERANCES ARE:
 <0.5mm ±0.05mm 0.5 - 6mm ±0.1mm 6 - 30mm ±0.2mm 30 - 120mm ±0.3mm ANGLES ±1°

NOTICE - These drawings, specifications, or other data (1) are, and remain the property of Amphenol corp. (2) must be returned upon request; and (3) are confidential and not to be disclosed to any person other than those to whom they are given by Amphenol Corp. the furnishing of these drawings, specifications, or other data by Amphenol Corp., or to any other person to anyone for any purpose is not to be regarded by implication or otherwise in any manner licensing, granting rights to permitting such holder or any other person to manufacture, use or sell any product, process or design, patented or otherwise, that may in any way be related to or disclosed by said drawings, specifications, or other data.

MATERIAL SEE NOTES	DRAWN A ARUN PRABU	DATE 23-Jan-12	TITLE HD-BNC STR PLUG FOR BELDEN 179DT/ RG 179 CABLE	Amphenol RF www.amphenolrf.com
REFERENCE EAR # 4690	ENGINEER A ARUN PRABU	DATE 23-Jan-12		
CONFIGURATION LEVEL: In Work	APPROVED K. CAPOZZI	DATE 8/15/12	SCALE: 11.0:1.0 SHEET 2 OF 2	DRAWING NO. 34-1042
FINISH	CAD FILE	DWG SIZE B	REV A	ITEM NO. 34-1042
				PART NO. 34-1042