

NOTES:

1. MATERIALS AND FINISHES:  
 BODY - BRASS, SILVER PLATING  
 CONTACT - BRASS, GOLD PLATING  
 INSULATOR - PTFE
2. MECHANICAL:  
 A. DURABILITY: 500 CYCLES MIN.  
 B. TEMPERATURE RANGE: -65° C TO +165° C
3. PACKAGING:  
 A. QUANTITY: SINGLE PACK  
 B. MARKING: BAG TO BE MARKED  
 "AMPHENOLRF, 82-4352, AND DATE CODE"
4. ASTERISK (\*) SHOWS CABLE ENTRY DIMENSIONS
5. RECOMMENDED ASSEMBLY PROCEDURES:  
 A. ITEMS CLAMP NUT, GASKET, CLAMP NUT, WASHER, INSULATOR & WASHER ARE ASSEMBLED TO CABLE PRIOR TO SOLDERING OF CENTER CONTACT.  
 B. CUSTOMER NOTE: SOLDER CONTACT TO CABLE.  
 C. ASSEMBLE INSULATOR ONTOCONTACT & THEN INSERT THE PRE-ASSEMBLED CABLE TERMINATION ASSY INTO THE PLUG BODY. SECURE BY TIGHTENING THE CABLE CLAMP NUT.

THIRD ANGLE PROJ.

REVISIONS

REV	DESCRIPTION	DATE	ECO	APPR
--	RELEASED TO MFG.	-----	-----	-----
H	REDRAWN IN PRO E, ADD COD	1/14/13	48616	RAK
J	ADD STAMPING TO COD	3/6/13	49452	CPM

# MIL-C-39012 INSPECTION

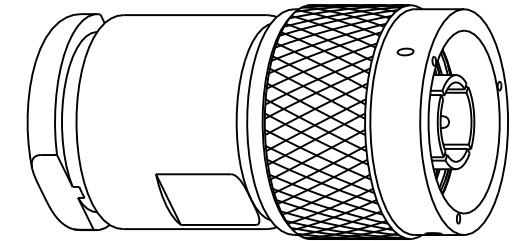

SCALE 1.500

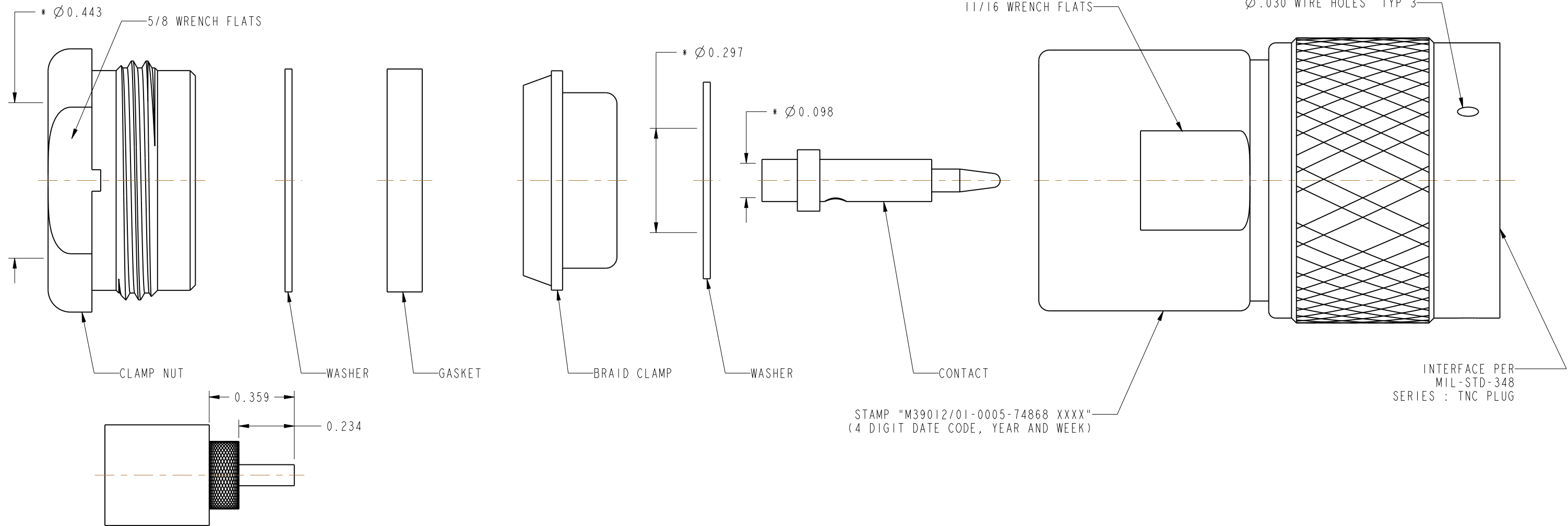

### RECOMMENDED CABLE STRIPPING DIMENSIONS

### CUSTOMER OUTLINE DRAWING

ALL OTHER SHEETS ARE FOR INTERNAL USE ONLY

UNLESS OTHERWISE SPECIFIED, DIMENSIONS ARE IN INCHES AND TOLERANCES ARE: 2 PLACE DECIMAL 3 PLACE DECIMAL ANGLES $\pm .015$ (0,381 mm) $\pm .005$ (0,127 mm) $\pm 1^\circ$	MATERIAL	DRAWN ABHAYA KISHORE	DATE 01-Jun-11	TITLE TYPE 'N' PLUG (CATEGORY A) CAPTIVATED CONTACT FOR RG 213,214 & 225 CABLES		Amphenol RF www.amphenolrf.com	
	REFERENCE DRAWING NO. : EPA 802207 M39012/01-0005	ENGINEER ABHAYA KISHORE	DATE 01-Jun-11				
	CONFIGURATION LEVEL: In Work	APPROVED K. CAPOZZI	DATE 1/14/13	SCALE: 3.5:1.0	SHEET 2 OF 2	ITEM NO.82-4352	
	FINISH	CAD FILE		DWG SIZE B	REV J	PART NO.82-4352	

NOTICE - These drawings, specifications, or other data (1) are, and remain the property of Amphenol corp. (2) must be returned upon request; and (3) are confidential and not to be disclosed to any person other than those to whom they are given by Amphenol Corp. the furnishing of these drawings, specifications, or other data by Amphenol Corp., or to any other person to anyone for any purpose is not to be regarded by implication or otherwise in any manner licensing, granting rights to permitting such holder or any other person to manufacture, use or sell any product, process or design, patented or otherwise, that may in any way be related to or disclosed by said drawings, specifications, or other data.