

Product Searches

- [7/16](#)
- [1.0/2.3](#)
- [1.6/5.6](#)
- [AFI](#)
- [AMC](#)
- [BNC / RP-BNC](#)
- [C](#)
- [FAKRA SMB](#)
- [FME](#)
- [HN](#)
- [MCX](#)
- [Mini BNC](#)
- [Mini-UHF](#)
- [Mini 75 Ohm](#)
- [SMB](#)
- [MMCX](#)
- [Precision \(APC\)](#)
- [QMA](#)
- [QWS](#)
- [SC](#)
- [SMA / RP-SMA](#)
- [SMB](#)
- [SMC](#)
- [SMP](#)
- [SSMB](#)
- [TNC / RP-TNC](#)
- [Triax](#)
- [Twin BNC](#)
- [Twinax](#)
- [Type F](#)
- [Type G](#)
- [Type N](#)
- [UHF](#)
- -----
- [Adapters](#)
- [Cable Assemblies](#)
- [Tools](#)
- [Accessories](#)
- -----
- [Product Search](#)
- -----
- [Inventory Search](#)

product details

← back



Please note: Images are for reference only

Amphenol Part Number:	082-5376-RFX
Description:	Type N RG58, 141, 142 Straight Plug
Product Series:	Type N
Product Type:	Connectors » Cable
Connector Body Style:	Straight
Gender:	Jack
Impedance:	50 Ohm
RoHS Compliant:	Yes

NOTES:

1. MATERIALS OF CONSTRUCTION:
 BODY & BARREL = BRASS, NICKEL PLATED
 FERRULE = COPPER, NICKEL PLATED
 CONTACT PIN = PHOSPHOR BRONZE, GOLD PLATED
 INSULATOR = TEFLON, MIL-P-19468
2. ELECTRICAL:
 A. IMPEDANCE: 50 OHM
3. MECHANICAL:
 A. TEMPERATURE RANGE: -65° C TO +165° C
4. PACKAGING:
 A. QUANTITY: SINGLE PACK
 B. MARKING: BAG TO BE MARKED
 "AMPHENOL, 82-5376-RFX, AND DATE CODE"

82-5376-RFX		REVISIONS			
DRAWING NO.	REV	DESCRIPTION	DATE	ECO	APPR
THIRD ANGLE PROJ.	A	RELEASE TO MFG.	9/13/00	43503	CPM
	C	RE-RELEASED AT WRONG REVISION LEVEL	9/28/00	43531	CPM
	D	TITLE WAS PLUG; ADD NOTES 2 THRU 4	6/19/06	46127	CPM

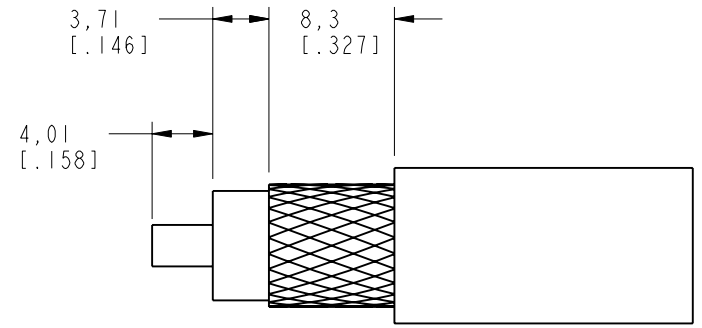

RECOMMENDED CABLE STRIPPING DIMENSIONS
SCALE 2.000

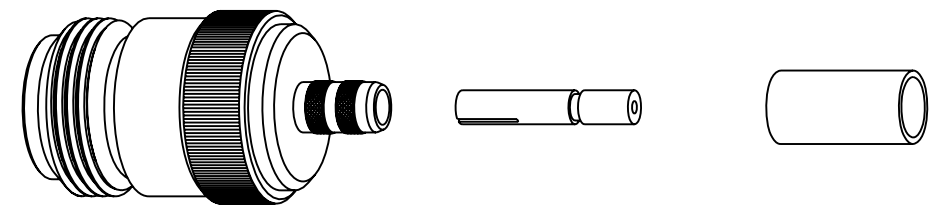

SCALE 1.500

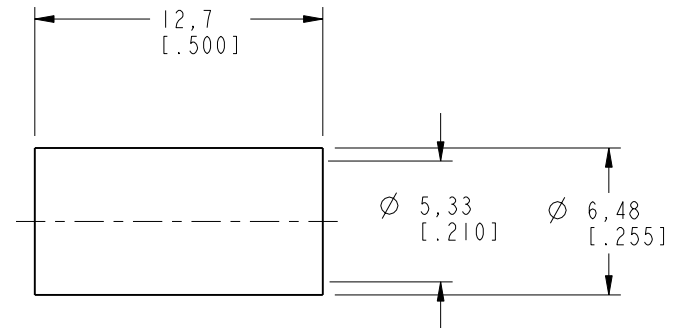
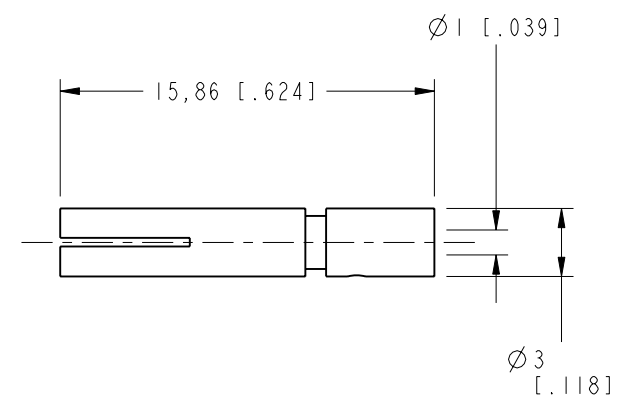
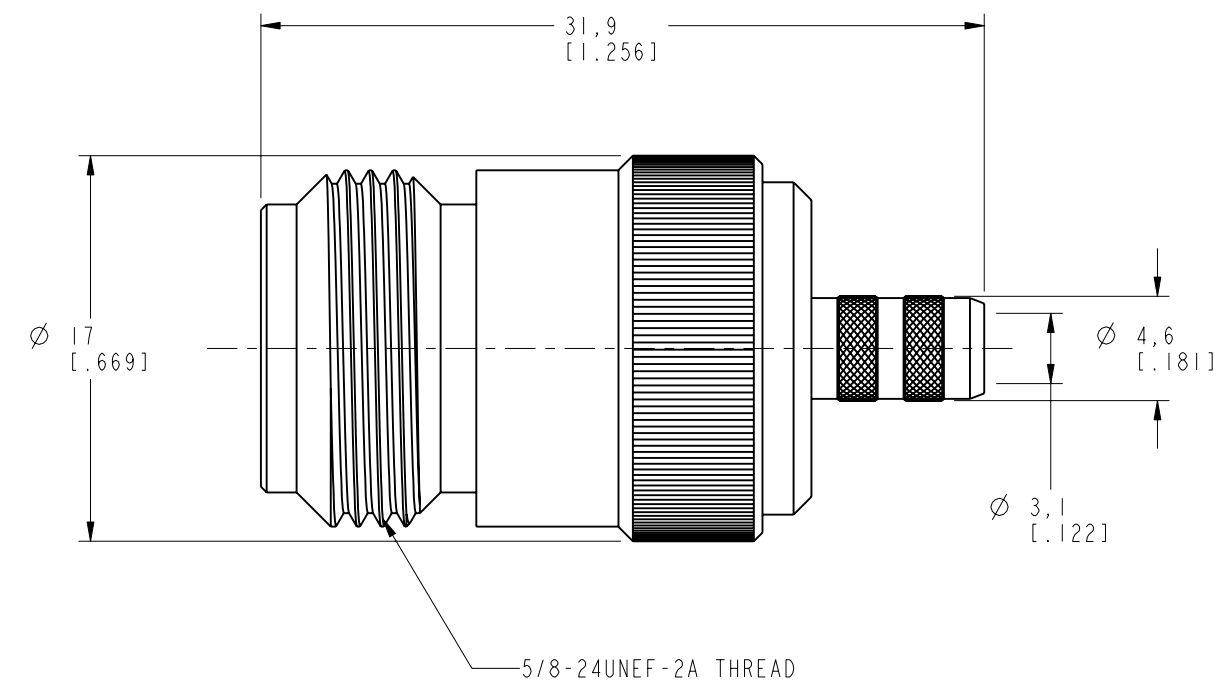

CUSTOMER OUTLINE DRAWING
ALL OTHER SHEETS ARE FOR INTERNAL USE ONLY

UNLESS OTHERWISE SPECIFIED, DIMENSIONS ARE IN MM (INCHES) AND TOLERANCES ARE: 0.5 - 6mm ±0.2mm 6 - 30mm ±0.4mm 30 - 120mm ±0.6mm	MATERIAL	DRAWN C. McGRATH	DATE 31-Aug-00	TITLE 'N' CRIMP CRIMP JACK FOR RG-58, 141 & 142 CABLES, 50 OHM	Amphenol Amphenol Corporation Communication and Network Products Division Danbury, CT U.S.A. 06810
	REFERENCE GEN# 82-5376-RFX_ASSY	ENGINEER T. AUBIN	DATE 31-Aug-00		
NOTICE - These drawings, specifications, or other data (1) are, and remain the property of Amphenol Corp. (2) must be returned upon request; and (3) are confidential and not to be disclosed to any person other than those to whom they are given by Amphenol Corp. The furnishing of these drawings, specifications, or other data by Amphenol Corp., or to any other person to anyone for any purpose is not to be regarded by implication or otherwise in any manner licensing, granting rights or permitting such holder or any other person to manufacture, use or sell any product, process or design, patented or otherwise, that may in any way be related to or disclosed by said drawings, specifications, or other data.		APPROVED T. AUBIN	DATE 9/27/00	CODE ID 74868	DWG SIZE B
				DRAWING NO. 82-5376-RFX	REV D

Description

Named for Paul Neill of Bell Labs and developed in the 1940's. The Type N offered the first true microwave performance.

Type N connector was developed to satisfy the need for a durable, weatherproof medium size RF connector with consistent performance through 11 GHz.

There are two families of Type N connectors:

- Standard N (Coaxial Cable)
- Helical N (Corrugated Cable)

Primary applications are the termination of medium to miniature size coaxial cable:

RG-8 and RG-225

RG-58 and RG-141

Features/Benefits

- Accommodates a wide range of medium to miniature sized RG coaxial cables in a rugged medium size design. Provides customer flexibility in their design and manufacturing with a durable connector.
- Broad line of Military (M39012 prefix), Industrial (UG prefix), and Commercial Grade (RFX suffix) products available. Gives customer choices in weighing cost versus performance benefits.
- Available in many styles: Plugs (Straight and Right Angle) and Jacks (Panel Mount, Bulkhead Mount, Receptacle). Meets many customer application demands.

Application

- Antennas
- Base Stations
- Broadcast
- Cable Assemblies
- Components
- Instrumentation
- Mil-Aero
- Radar
- Radios
- Satcom
- Surge Protection
- WLAN



Type N

Specifications	226
Cable Plugs	227
Right Angle Plugs	228
Jacks	229-232
Receptacles, Accessories	234-235
Adapters	236

Helical N Corrugated Cable Connectors

Specifications	239
Plugs	240-241
Jacks	242-243

ELECTRICAL

Impedance	50 ohms
Frequency range	0-11 GHz
Voltage rating	1,500 volts peak
Dielectric withstanding voltage	2,500 volts rms.
VSWR (MIL-C-39012 cable connectors)	M39012 straight connectors: 1.3 max. 0-11 GHz M39012 right angle: 1.35 max. 0-11 GHz
Other	Contact resistance: center contact 1.0 milliohm outer contact 0.2 milliohm RF leakage: -90 dB minimum at 3 GHz Insertion loss: .15 dB maximum at 10 GHz Insulation resistance: 5000 megohms minimum

MECHANICAL

Mating	5/8-24 threaded coupling
Cable affixment (braid or jacket)	All crimps: hex braid crimp. Clamps: screw-thread nut and braid clamp
Cable affixment (center conductor)	Crimp: crimp or solder All others: solder only
Captivated contact	All crimps. Others, where specified.
Cable retention	Crimps: 60-120 lbs. Clamps: 30-70 lbs.

MATERIAL

Contacts	Male: brass; Female: phosphor bronze or beryllium copper. Silver or gold plated
Other metal parts	Brass: ASTROplate® finish except M39012 silver.
Insulators	TFE, copolymer of styrene or glass-TFE (hermetic seal)
Weatherproof gaskets	Silicone rubber or synthetic rubber
Crimp ferrule	Copper

ENVIRONMENTAL

Temperature range	TFE -65°C to + 165°C Copolymer of Styrene: - 55°C to + 85°C
Weatherproof	All series N with gaskets are weatherproof
Hermetic seals	Pass helium leak test of 2×10^{-8} cc/sec
Pressurized Shock	Compression seal MIL-Std. 202 method 213
Vibration	MIL-Std. 202 method 204 (test cond. B)
Moisture resistance	MIL-Std. 202 method 106
Corrosion	MIL-Std. 202 method 101 (test cond. B)
Temperature cycling	MIL-Std. 202 method 102 (test cond. C)
Altitude	MIL-Std. 202 method 105 (test cond. C)

MILITARY SPECIFICATIONS

MIL-C-39012 & MIL-A-55339	Where applicable
---------------------------	------------------

NOTE: These characteristics are typical and may not apply to all connectors.

PLUG

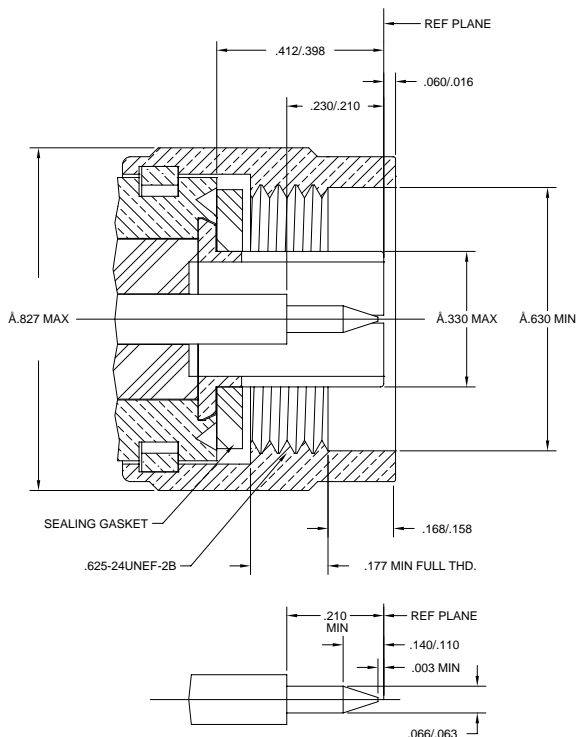

JACK

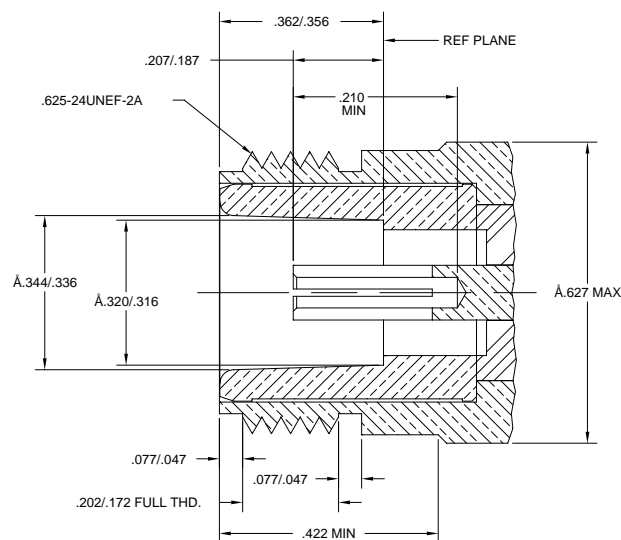

Type N Straight Jacks

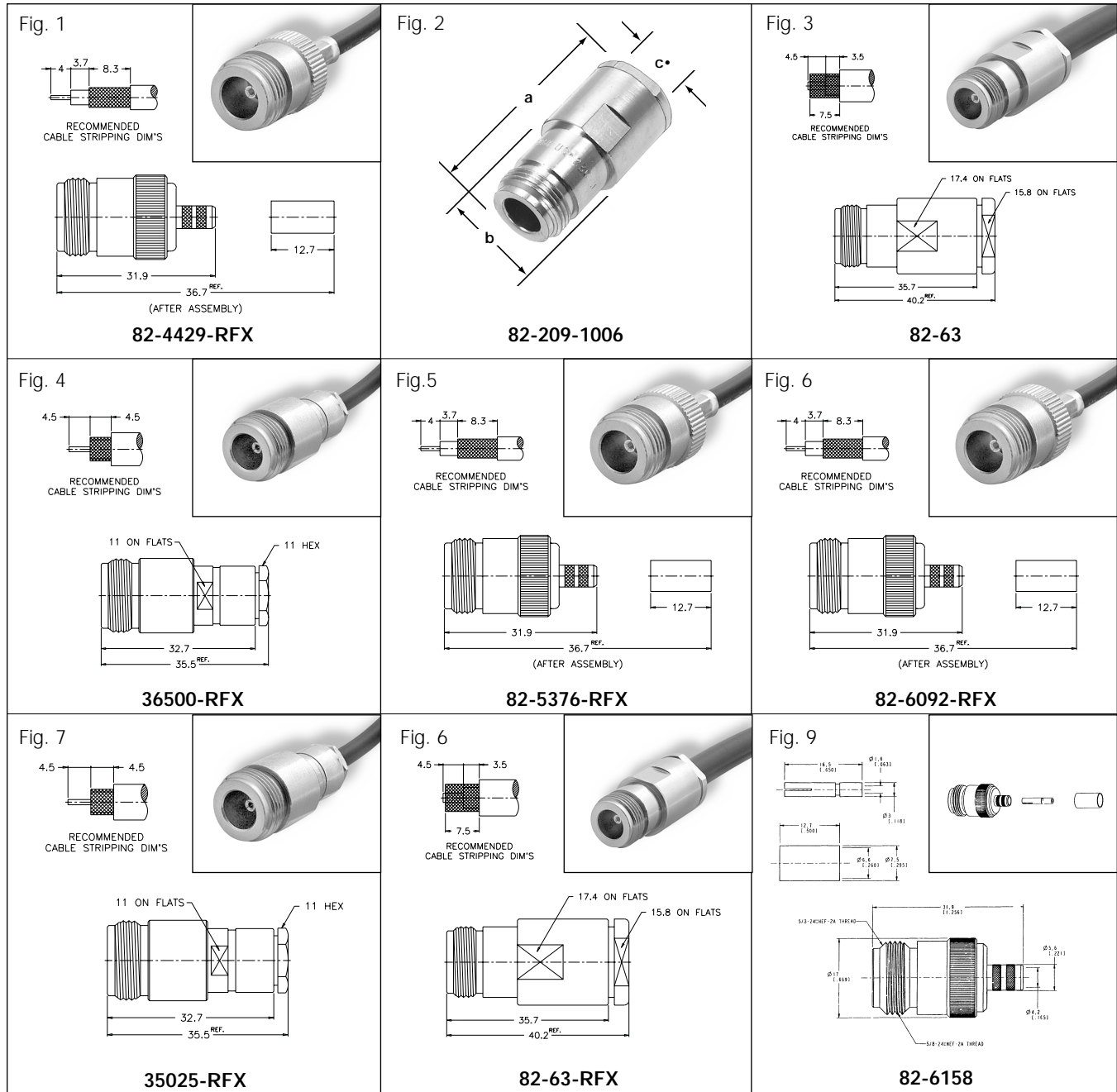

N STRAIGHT JACKS

Cable RG-/U	Conn. Type	Cable Attachment		Dimensions, inches (millimeters)					Notes			Military Number	Amphenol Number	Fig	
		Outer	Inner	a	b	c •	d	e	CAI	Plt.	Ins.				
8, 9, 87A, 144, 165, 213, 214, 216, 225	Str.	Clamp	Solder	1.56(39.7)	.750(19.1)	.440(11.2)	—	—	C8	P1	D1	UG-23B/U	82-63	3	▲
B9913, Times AA-6146	Str.	Clamp	Solder	1.56(39.6)	.750(19.1)	.443(11.3)	—	—	C8	P1	D9	—	82-209-1006	2	
59, 62	Str.	Crimp	Crimp	1.44 (36.7)	.866 (22)	.210 (5.3)	.866 (22)	.250 (64)	—	P7	D1	—	82-5376-RFX	5	
59	Str.	Crimp	Crimp	1.44 (36.7)	—	—	—	—	—	P7	D1	—	82-6092-RFX	6	▲
58, 141	Str.	Clamp	Solder	1.90 (35.5)	.630 (16)	.212 (5.4)	—	—	—	P7	D1	—	35025-RFX	7	▲
8, 213, 214	Str.	Clamp	Solder	1.58 (40.2)	.750 (19)	.437 (11.1)	—	—	—	P7	D1	—	82-63-RFX	8	
59, 62	Str.	Clamp	Solder	.96 (24.5)	.827 (21)	.143 (3.6)	—	—	—	P7	D1	—	36500-RFX	4	
LMR240, 8X	Str.	Clamp	Solder	.96 (24.5)	.827 (21)	.143 (3.6)	—	—	—	P7	D1	—	82-6158	9	
213	Str.	Crimp	Crimp	1.44 (36.6)	.669 (17)	.440 (11.2)	—	—	—	P7	D1	—	82-4429-RFX	1	

• accommodates cable diameter ■ Captivated contact ★ IBM6028495 ▼ max. panel when rear mounted thru panel ▲ Distributor stocked