

NOTES:

1. MATERIALS AND FINISHES:
 BODY - BRASS, SILVER PLATING (.000200 MIN THICK)
 INNER AND OUTER CONTACT -BRASS, GOLD PLATING (.000050 MIN THICK)
 BRAID CLAMP- BRASS, SILVER PLATING (.000200 MIN THICK)
 INNER FERRULE- BRASS, SILVER PLATING (.000200 MIN THICK)
 OUTER FERRULE- COPPER, SILVER PLATING (.000200 MIN THICK)
 CLAMP NUT- BRASS, SILVER PLATING (.000200 MIN THICK)
 GASKET- SILICON RUBBER
 INSULATOR - PTFE
2. ELECTRICAL:
 A. IMPEDANCE: 50 OHM
 B. FREQUENCY RANGE: DC - 11 GHz
 C. VSWR(RETURN LOSS): 1.35 MAX.
 D. DIELECTRIC WITHSTANDING VOLTAGE: 1500 VRMS, MIN.
3. MECHANICAL:
 A. TEMPERATURE RANGE: -65° C TO 165° C
4. PACKAGING:
 A. QUANTITY: SINGLE PACK
 B. MARKING: BAG TO BE MARKED
 "AMPHENOL, 82-5773-1, AND DATE CODE"

THIRD ANGLE PROJ.

REVISIONS

REV	DESCRIPTION	DATE	ECO	APPR
A	OFFICIAL ENG. RELEASE TO MFG.	6/19/86	32906	PM
D	McAIR SPEC WAS "REV. A"; ADDED CABLE ENTRY DIMS.; ADDED NOTES 6, 7, & 8	7/27/92	38907	DL/RV
E	ADDED DATE CODE 'YYWW' TO STAMP; REMOVED NOTES 3, 5; BOEING-ST. LOUIS SPEC WAS "McAIR, REV. D"	8/2/11	48686	MJS

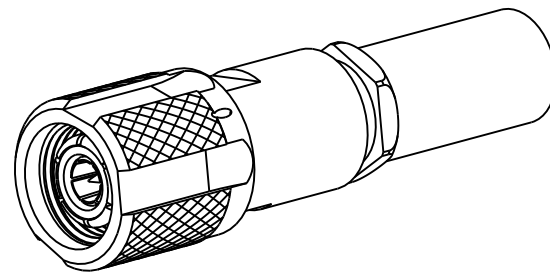

SCALE 1.500

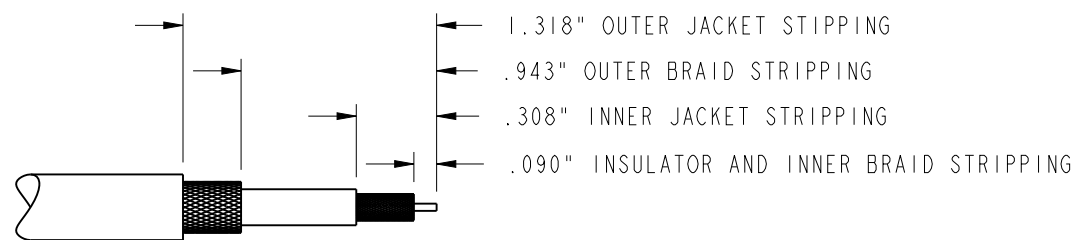
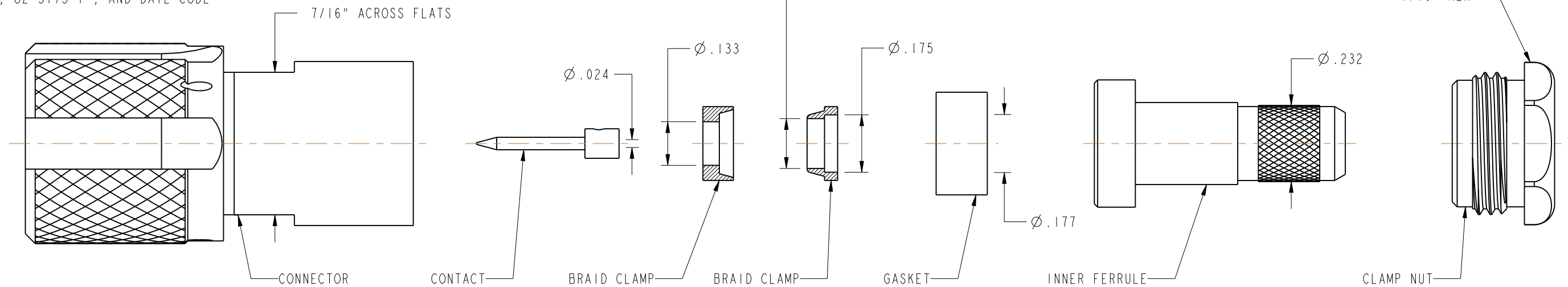

RECOMMENDED STRIPPING DIMENSIONS

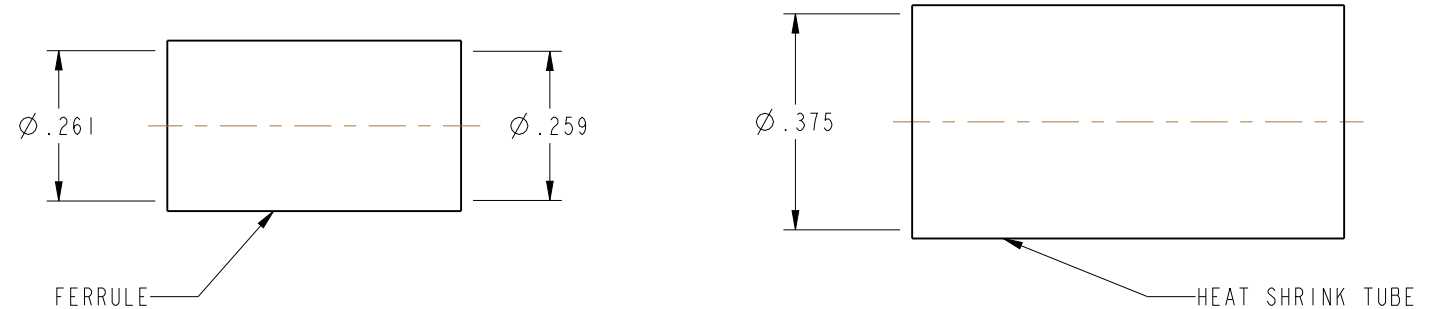

CUSTOMER OUTLINE DRAWING

ALL OTHER SHEETS ARE FOR INTERNAL USE ONLY

UNLESS OTHERWISE SPECIFIED, DIMENSIONS ARE IN METRIC AND TOLERANCES ARE: <0.5mm ±0.05mm 0.5 - 6mm ±0.1mm 6 - 30mm ±0.2mm 30 - 120mm ±0.3mm ANGLES ±1°	MATERIAL	---	DRAWN	P. MATULA	DATE	4/29/86	TITLE TNC STRAIGHT TRIAX PLUG	Amphenol RF www.amphenolrf.com
	REFERENCE	BOEING-ST. LOUIS 5M2497 S I I,	ENGINEER	D. ROYCE	DATE	6/12/86		
	FINISH		APPROVED	K. CAPOZZI	DATE	7/22/11	SCALE: 3.0:1.0 SHEET 2 OF 2	ITEM NO.82-5773-1
			CAD FILE		DWG SIZE	B	REV	E

NOTICE - These drawings, specifications, or other data (1) are, and remain the property of Amphenol corp. (2) must be returned upon request; and (3) are confidential and not to be disclosed to any person other than those to whom they are given by Amphenol Corp. the furnishing of these drawings, specifications, or other data by Amphenol Corp., or to any other person to anyone for any purpose is not to be regarded by implication or otherwise in any manner licensing, granting rights to permitting such holder or any other person to manufacture, use or sell any product, process or design, patented or otherwise, that may in any way be related to or disclosed by said drawings, specifications, or other data.