

REV.	DATE	DESCRIPTION
A	06/05/03	UPDATE DRAWING FORMAT

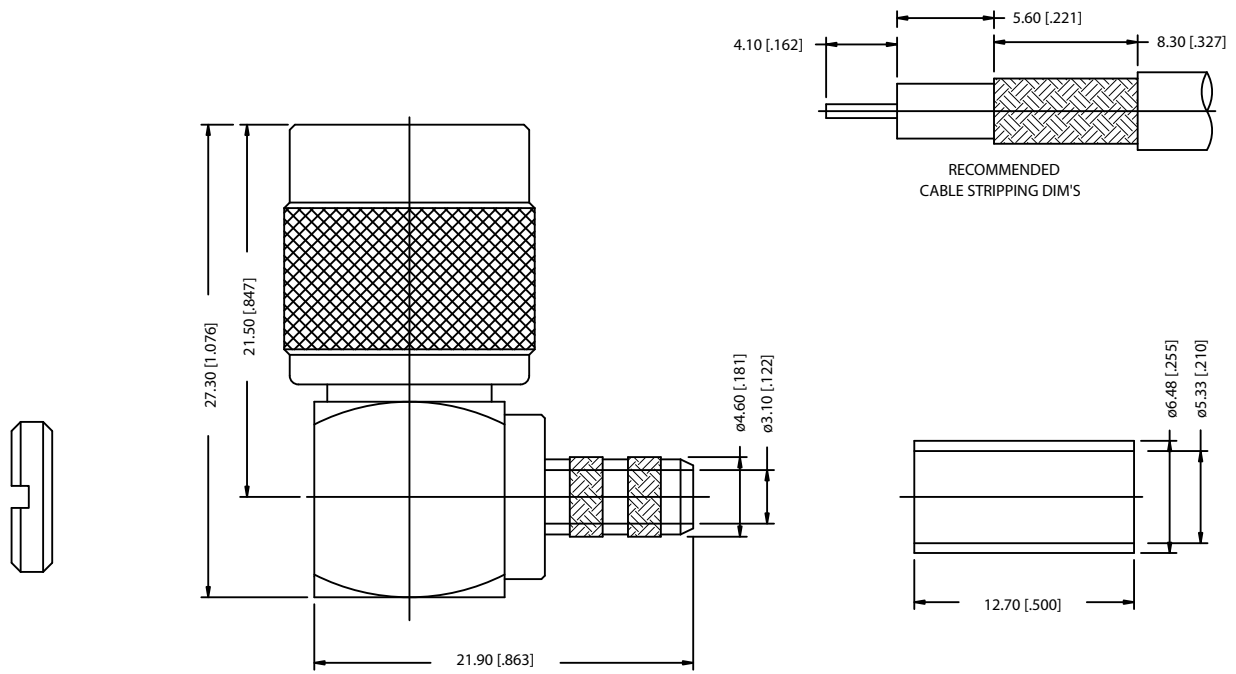

8				
7				
6				
5	NUT	BRASS	NICKEL	1
4	FERRULE	COPPER	NICKEL	1
3	CONTACT PIN	BRASS	GOLD	1
2	INSULATOR	DELTRIN	NATURAL	1
1	BODY	BRASS	NICKEL	1
	DESCRIPTION	MATERIAL	FINISH	QTY

UNLESS OTHERWISE SPECIFIED DIMENSIONS ARE IN MILLIMETERS. DIMENSIONS IN [ ] ARE IN INCHES AND FOR CUSTOMER REFERENCE ONLY.

UNLESS OTHERWISE SPECIFIED TOLERANCES FOR MILLIMETERS ARE:  
0.5 - 8mm ± 0.20mm  
8 - 30mm ± 0.40mm  
30 - 120mm ± 0.50mm

UNLESS OTHERWISE SPECIFIED TOLERANCES FOR INCHES ARE:  
.020 - .315 = ± 0.007"  
.315 - 1.180 = ± 0.015"  
1.180 - 4.724 = ± 0.020"

DO NOT SCALE DRAWING

APPROVALS	DATE
DRAWN G.R.S.	06/05/03
CHECKED	
ISSUED	
SHEET 1 OF 1	
CAD FILE	
C:/122/122140.DWG	

<h1>Amphenol - Connex</h1>	
PART DESCRIPTION TNC R/A CRIMP PLUG (FOR RG-58/u, 58C/u, 141/u CABLE)	
PART NO. 122140	
DWG. NO.	122140.DWG
REV.	A
SIZE	A
SCALE	NA