

REV.	DATE	DESCRIPTION
A	01/10/04	UPDATE DRAWING FORMAT

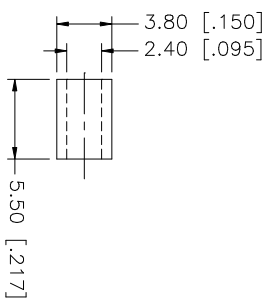
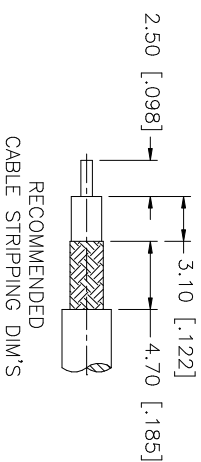
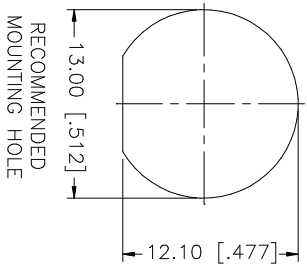
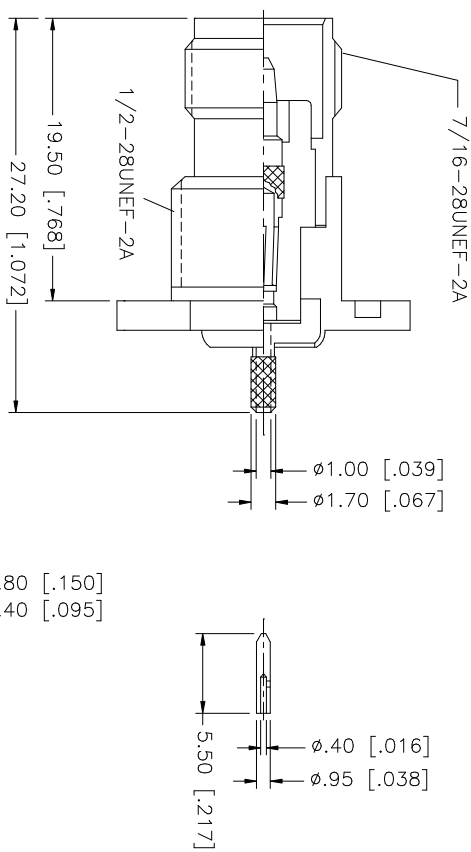
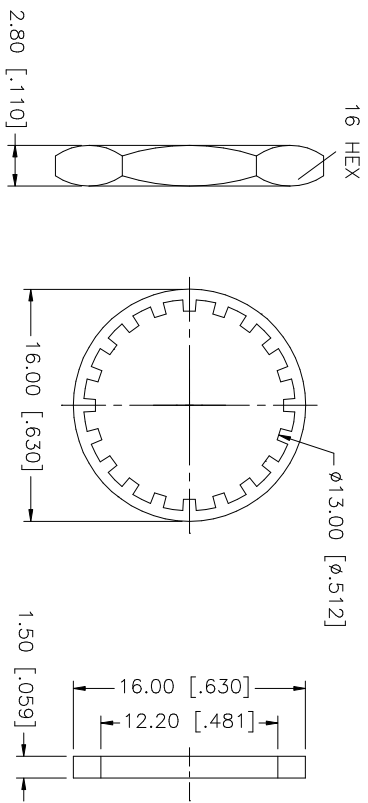

CRIMP NOTES:

1. CRIMPED FERRULE
HEX CRIMP SIZE .128"
2. CRIMPED CONTACT PIN
SQ. CRIMP SIZE .7mm
3. MAX. PANEL THICKNESS = 5.5mm

QTY	DESCRIPTION	MATERIAL	FINISH	QTY	DO NOT SCALE DRAWING	APPROVALS	DATE	PART DESCRIPTION	
1	16 HEX	COPPER	NICKEL	1		DRAWN	G.R.S.	01/10/04	<p>Amphenol Connex</p> <p>TNC REVERSE BULKHEAD CRIMP JACK (FOR RG-178B/U, 196A/U)</p> <p>122370RP</p>
1	HEX NUT	BRASS	NICKEL	1		CHECKED			
1	LOCK WASHER	BRASS	NICKEL	1		ISSUED			
1	GASKET	RUBBER	RED	1		SHEET	1 OF 1		
1	CONTACT PIN	PHOS. BRONZE	GOLD	1					
1	INSULATOR BODY	TEFLON BRASS	NATURAL NICKEL	1					
	DESCRIPTION	MATERIAL	FINISH	QTY					

UNLESS OTHERWISE SPECIFIED DIMENSIONS ARE IN MILLIMETERS. DIMENSIONS IN [] ARE IN INCHES AND FOR CUSTOMER REFERENCE ONLY.

UNLESS OTHERWISE SPECIFIED TOLERANCES FOR MILLIMETERS ARE:

0.5 - 8mm ± 0.20mm
8 - 30mm ± 0.40mm
30 - 120mm ± 0.50mm

UNLESS OTHERWISE SPECIFIED TOLERANCES FOR INCHES ARE:

.020 - .315 = ± 0.007"
.315 - 1.180 = ± 0.015"
1.180 - 4.724 = ± 0.020"

CAD FILE	APPROVALS	DATE	PART NO.
C:/122/122370RP.DWG			122370RP
DWG. NO.	REV.	SIZE	SCALE
122370RP.DWG	A	A	NA