

REV.	DATE	DESCRIPTION
A	12/23/02	MODIFY CONTACT PIN LENGTH

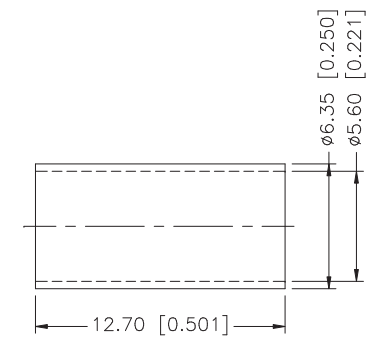
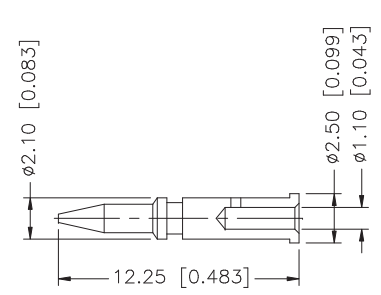
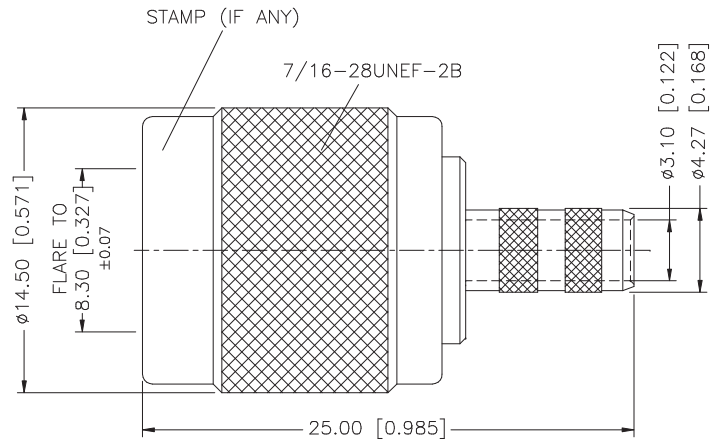
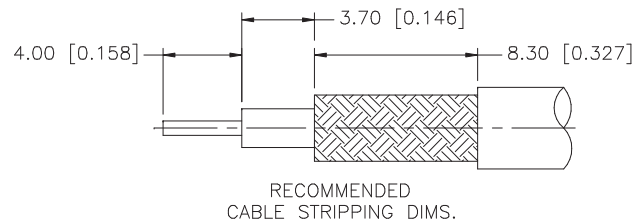

- NOTE:
1. CRIMPED FERRULE
HEX CRIMP SIZE .213"
 2. CRIMPED CONTACT PIN
HEX CRIMP SIZE .068"

DESCRIPTION	MATERIAL	FINISH	QTY	DO NOT SCALE DRAWING	APPROVALS	DATE	Amphenol Connex						
8							PART DESCRIPTION TNC CRIMP PLUG (FOR RG-55/U,142A/U,223/U,400/U CABLE)						
7						PART NO. 122372							
6	FERRULE	COPPER	NICKEL	1							DWG. NO. 122372.DWG		
5	GASKET	RUBBER	RED	1			REV. A						
4	INSULATOR	DELTRIN	NATURAL	1			SIZE A						
3	CONTACT PIN	BRASS	GOLD	1			SCALE NA						
2	SHELL/BODY	BRASS	NICKEL	1									
1													

UNLESS OTHERWISE SPECIFIED DIMENSIONS ARE IN MILLIMETERS. DIMENSIONS IN [] ARE IN INCHES AND FOR CUSTOMER REFERENCE ONLY.

UNLESS OTHERWISE SPECIFIED TOLERANCES FOR MILLIMETERS ARE:
0.5 - 8mm ± 0.20mm
8 - 30mm ± 0.40mm
30 - 120mm ± 0.50mm

UNLESS OTHERWISE SPECIFIED TOLERANCES FOR INCHES ARE:
.020 - .315 = ± 0.007"
.315 - 1.180 = ± 0.015"
1.180 - 4.724 = ± 0.020"

DRAWN	G.R.S.	12/23/02
CHECKED		
ISSUED		
SHEET	1 OF 1	
CAD FILE	C:/122/122372.DWG	