

REV.	DATE	DESCRIPTION
A	10/28/99	MODIFY BODY AND CONTACT DIMS
B	01/13/03	ADD INSULATOR / UPDATE DIMENSIONS

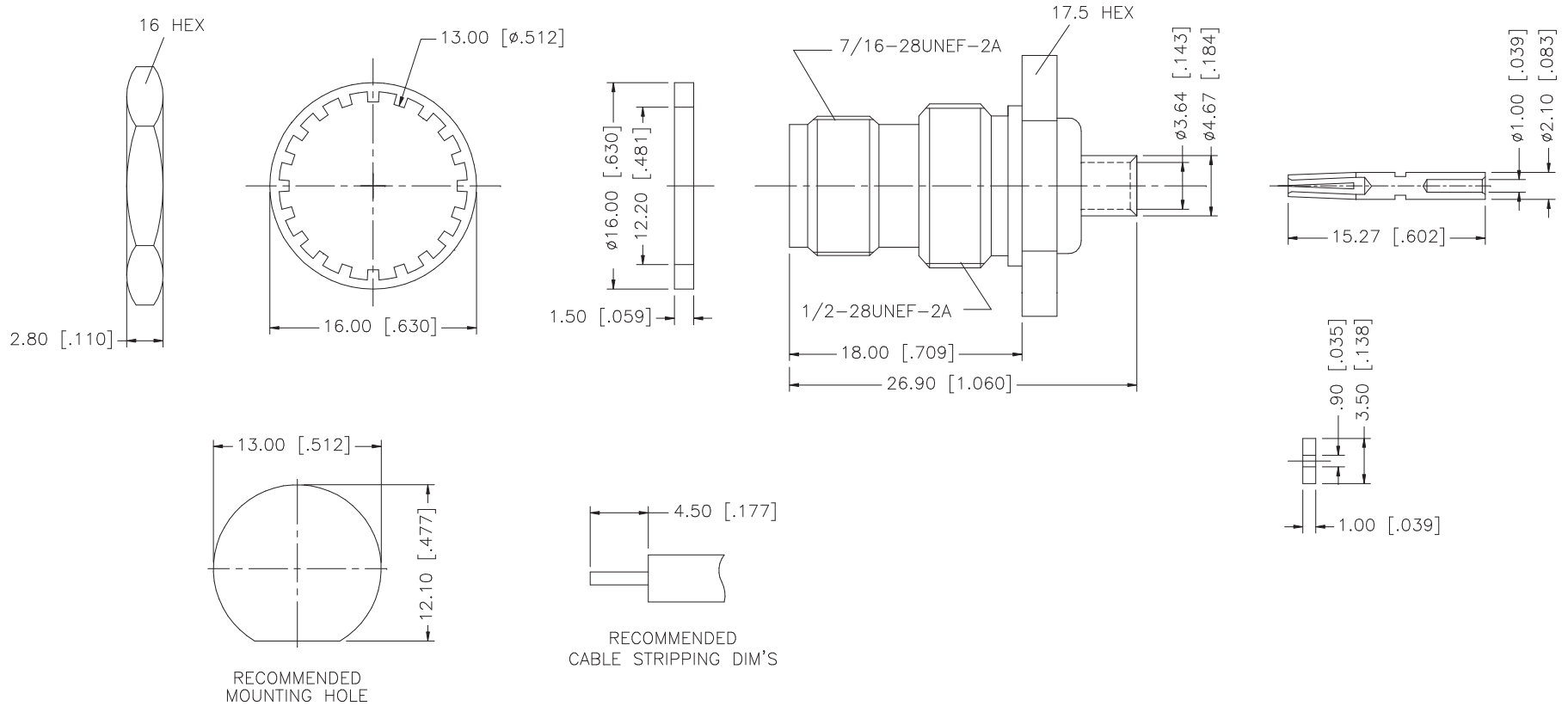

QTY	DESCRIPTION	MATERIAL	FINISH	QTY	DO NOT SCALE DRAWING	CAD FILE	DWG. NO.	REV.	SIZE	SCALE	
8	GASKET	RUBBER	RED	1	<small>UNLESS OTHERWISE SPECIFIED DIMENSIONS ARE IN MILLIMETERS; DIMENSIONS IN [ ] ARE IN INCHES AND FOR CUSTOMER REFERENCE ONLY.</small> <small>UNLESS OTHERWISE SPECIFIED TOLERANCES FOR MILLIMETERS ARE:</small> 0.5 - 8mm ± 0.20mm 8 - 30mm ± 0.40mm 30 - 120mm ± 0.50mm <small>UNLESS OTHERWISE SPECIFIED TOLERANCES FOR INCHES ARE:</small> .020 - .315 = ± 0.007" .315 - 1.180 = ± 0.015" 1.180 - 4.724 = ± 0.020"	C:/122/122401DWG	122401.DWG	B	A	NA	
7	LOCK WASHER	BRASS	NICKEL	1							
6	HEX NUT	BRASS	NICKEL	1							
5	BARREL	BRASS	GOLD	1							
4	CONTACT PIN	PHOS. BRONZE	GOLD	1							
3	INSULATOR	TEFLON	NATURAL	2							
2	REAR BODY	BRASS	GOLD	1							
1	BODY	BRASS	NICKEL	1							
					APPROVALS	DATE	<h1 style="text-align: center;">Amphenol Connex</h1> <p style="text-align: center;">PART DESCRIPTION TNC BULKHEAD DIRECT SOLDER JACK .141" SIMI RIGID CABLE</p> <p style="text-align: center;">PART NO. 122401</p>				
					DRAWN	G.R.S.					01/13/03
					CHECKED						
					ISSUED						
					SHEET	1 OF 1					