

REV.	DATE	DESCRIPTION
A	01/22/04	UPDATE DRAWING FORMAT

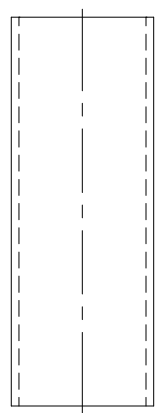
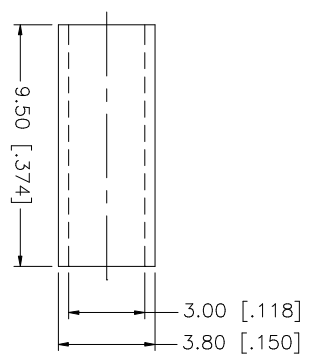
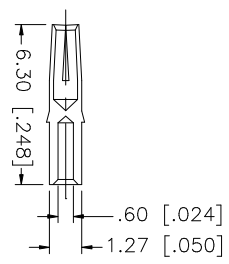
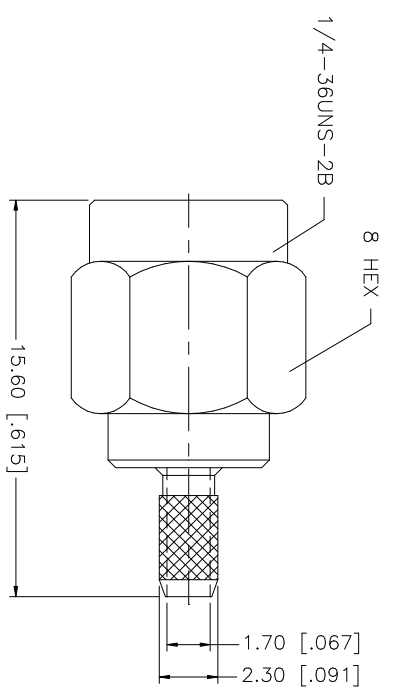
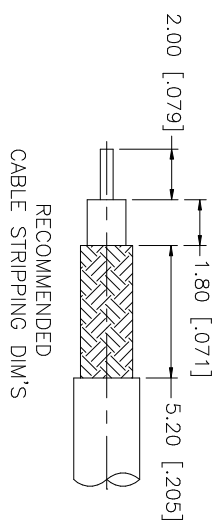

NOTE:
 1. CRIMPED FERRULE
 HEX CRIMP SIZE .128"
 2. CONTACT PIN TO SOLDER

Amphenol Connex

PART DESCRIPTION
SMA REVERSE POLARITY CRIMP PLUG
 (RG-174/U, 188A/U, 316/U)

QTY	FINISH	MATERIAL	DESCRIPTION
1	GOLD	BRASS	BODY
1	NATURAL	TEFLON	INSULATOR
1	GOLD	BER. COPPER	CONTACT PIN
1	GOLD	COPPER	FERRULE
1			HEAT SHRINK TUBING

UNLESS OTHERWISE SPECIFIED DIMENSIONS ARE IN MILLIMETERS. DIMENSIONS IN [] ARE IN INCHES AND FOR CUSTOMER REFERENCE ONLY. TOLERANCES FOR MILLIMETERS ARE:
 0.5 - 8mm ± 0.20mm
 8 - 30mm ± 0.40mm
 30 - 120mm ± 0.50mm

UNLESS OTHERWISE SPECIFIED DIMENSIONS ARE IN INCHES. DIMENSIONS IN [] ARE IN MILLIMETERS. DIMENSIONS IN [] ARE IN INCHES AND FOR CUSTOMER REFERENCE ONLY. TOLERANCES FOR INCHES ARE:
 .020 - .315 = ± 0.007"
 .315 - 1.180 = ± 0.015"
 1.180 - 4.724 = ± 0.020"

DO NOT SCALE DRAWING

APPROVALS	DATE
DRAWN G.R.S.	01/22/04
CHECKED	
ISSUED	
SHEET 1 OF 1	

CAD FILE C:/132/132114RP.DWG

DWG. NO. 132114RP.DWG

REV. A

SIZE A

SCALE NA