

REV.	DATE	DESCRIPTION
A	04/31/03	UPDATE DRAWING FORMAT

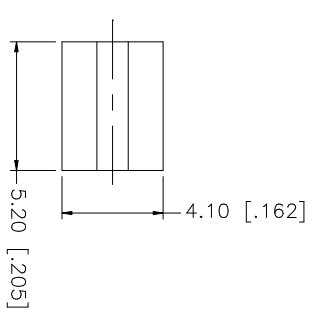
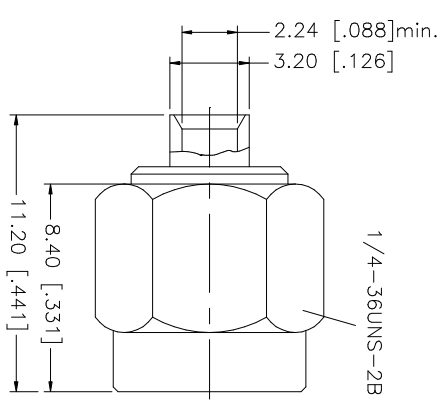
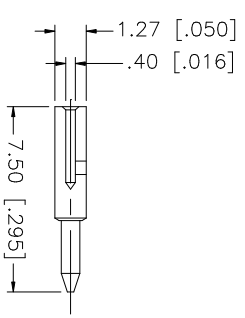
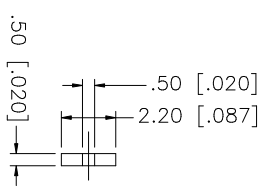
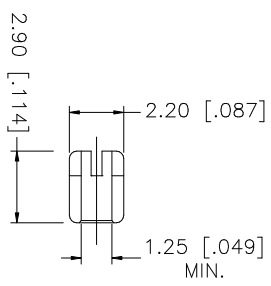
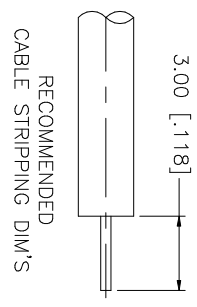

QTY	FINISH	MATERIAL	DESCRIPTION
1	GOLD	BRASS	INSULATOR BODY
1	NATURAL	TEFLON	INSULATOR
1	GOLD	BRASS	CONTACT PIN
1	GOLD	BRASS	SOLDER BARREL
1			
1			
1			
1			
1			

APPROVALS	DATE
DRAWN G.R.S.	04/31/03
CHECKED	
ISSUED	
SHEET 1 OF 1	

DO NOT SCALE DRAWING	CAD FILE	DWG. NO.	REV.	SIZE	SCALE
	C:/132/132249.DWG	132249.DWG	A	A	NA

Amphenol Connex

SMA DIRECT SOLDER PLUG
(FOR .047" SEMI-RIGID CABLE)

132249