

REV.	DATE	DESCRIPTION
A	04/31/03	UPDATE DRAWING FORMAT

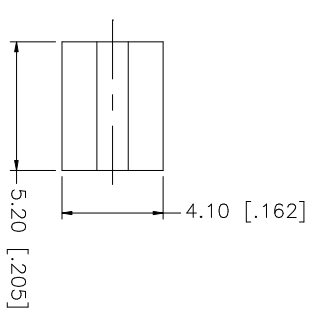
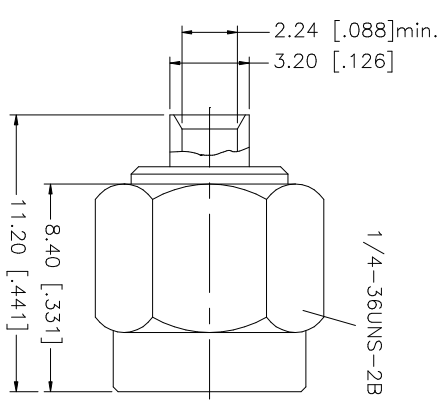
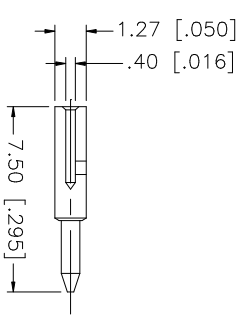
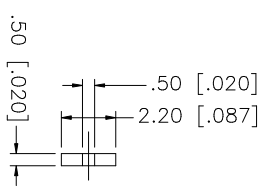
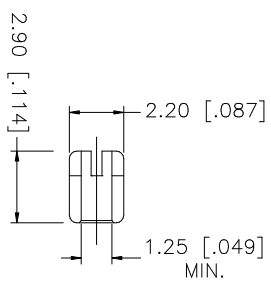
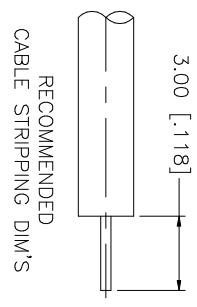

DESCRIPTION	MATERIAL	FINISH	QTY	DO NOT SCALE DRAWING	APPROVALS	DATE	PART DESCRIPTION	DWG. NO.	REV.	SIZE	SCALE
8				UNLESS OTHERWISE SPECIFIED DIMENSIONS ARE IN MILLIMETERS; DIMENSIONS IN [] ARE IN INCHES AND FOR CUSTOMER REFERENCE ONLY.			Amphenol Connex SMA DIRECT SOLDER PLUG (FOR .047" SEMI-RIGID CABLE)	132249	A	A	NA
7				UNLESS OTHERWISE SPECIFIED DIMENSIONS ARE IN MILLIMETERS; DIMENSIONS IN [] ARE IN INCHES AND FOR CUSTOMER REFERENCE ONLY.							
6				UNLESS OTHERWISE SPECIFIED DIMENSIONS ARE IN MILLIMETERS; DIMENSIONS IN [] ARE IN INCHES AND FOR CUSTOMER REFERENCE ONLY.							
5				UNLESS OTHERWISE SPECIFIED DIMENSIONS ARE IN MILLIMETERS; DIMENSIONS IN [] ARE IN INCHES AND FOR CUSTOMER REFERENCE ONLY.							
4	SOLDER BARREL	BRASS	1	0.5 - 8mm ± 0.20mm	DRAWN	04/31/03					
3	CONTACT PIN	BRASS	1	8 - 30mm ± 0.40mm	CHECKED						
2	INSULATOR	TEFLON	1	30 - 120mm ± 0.30mm	ISSUED						
1	BODY	BRASS	1	UNLESS OTHERWISE SPECIFIED DIMENSIONS ARE IN MILLIMETERS; DIMENSIONS IN [] ARE IN INCHES AND FOR CUSTOMER REFERENCE ONLY.	SHEET	1 OF 1					
DESCRIPTION				DO NOT SCALE DRAWING	CAD FILE						

Our Products

- [7/16](#)
- [BNC](#)
- [D-Sub](#)
- [FME](#)
- [MCX](#)
- [MMCX](#)
- [SMA](#)
- [SMB](#)
- [SMC](#)
- [TNC](#)
- [Twin BNC](#)
- [Type F](#)
- [Type N](#)
- [UHF](#)

[Between-Series Adapters](#)

[Shielded Terminations](#)

[Strain-Relief Boots](#)

[Tools](#)

[View All Products](#)

SMA connector series

[Features & Benefits](#) |
 [Applications](#) |
 [Assembly Instructions](#)
[Stainless Steel Specs](#) |
 [Brass Specs](#) |
 [Phase Adjustable Specs](#) |
 [Reverse Polarity Specs](#)

SMA is an acronym for SubMiniature version A and was developed in the 1960's. It uses a threaded interface. 50 Ω SMA connectors are semi-precision, subminiature units that provide excellent electrical performance from DC to 18 GHz. These high-performance connectors are compact in size and mechanically have outstanding durability.



For phase array radar, test equipment, ILS landing systems and other instrumentation using phase matching techniques, these SMA connectors for semi-rigid coaxial cables and the SMA Plug-to-Jack adapter offer a precise and simple means of phase adjustment for microwave devices. Built in accordance with MIL-C-39012 and CECC 22110/111, SMA connectors can be mated with all connectors that meet these spec mating diameters regardless of manufacturer.

SMA is available both in Standard and Reverse Polarity. Reverse polarity is a keying system accomplished with a reverse interface, and ensures that reverse polarity interface connectors do not mate with standard interface connectors. Amphenol accomplishes this by inserting female contacts into plugs and male contacts into jacks. Other manufacturers may use reverse threading to accomplish reverse polarity keying.

SMA Coaxial Connectors

DIRECT SOLDER FOR SEMI-RIGID .047", .085" AND .141" CABLE

- [Straight Cable Plug - Cable Center Contact](#)
- [Straight Cable Plug - Cable Center Contact](#)
- [Straight Cable Plug - Cable Center Contact](#)
- [Straight Cable Plug With Contact](#)
- [Straight Cable Plug - With Contact And Torque Nut](#)
- [Right Angle Cable Plug DC - 12.4Ghz](#)
- [Straight Cable Jack](#)
- [Bulkhead Feedthrough Cable Jack - O-Ring Seal](#)
- [Panel Mount Cable Jack - 4 Hole Square Flange](#)
- [Panel Mount Cable Jack — 2 Hole Flange](#)

CRIMP TERMINATIONS FOR FLEXIBLE CABLE

- [Straight Crimp Plug - Standard Cable](#)
- [Straight Crimp Plug - Miniature Cable](#)
- [Right Angle Crimp Plug - Standard Cable](#)
- [Right Angle Crimp Plug - Miniature Cable](#)
- [Straight Crimp Jack - Standard Cable](#)
- [Straight Crimp Jack - Miniature Cable](#)
- [Bulkhead Crimp Jack — Standard Cable](#)
- [Bulkhead Crimp Jack - Miniature Cable](#)
- [Bulkhead Crimp Jack - O-Ring Seal - Standard Cable](#)
- [Bulkhead Crimp Jack -O-Ring Seal- Miniature Cable](#)
- [Right Angle Bulkhead Crimp Jack - Standard & Miniature Cable](#)
- [Panel Crimp Jack - Standard Cable](#)
- [Panel Crimp Jack - Miniature Cable](#)

CLAMP TERMINATIONS FOR FLEXIBLE CABLE

- [Straight Clamp Plug - Standard Cable](#)
- [Straight Clamp Plug - Miniature Cable](#)
- [Straight Clamp Jack — Standard Cable](#)
- [Straight Clamp Jack — Miniature Cable](#)
- [Bulkhead Clamp Jack - Standard Cable](#)

[Plug-To-Jack Adapter - Right Angle](#)

[Jack-To-Jack Adapter-Right Angle](#)

[Jack-To-Jack-To-Jack Tee Adapter](#)

[Jack-To-Plug-To-Jack Tee Adapter](#)

ACCESSORIES

[Male Cap](#)

Features & Benefits

- Broadband performance DC to 18 GHz with low reflection stainless steel construction and ¼ - 36 threaded coupling offers high performance in a compact design.
- Low cost Commercial Grade (Brass SMA) available in nickel or gold plating which provides approximately 30% cost reduction with 250 mating cycles.
- Available for .085" and .141" diameter semi-rigid cables and all the standard flexible cables including double shielded RG-316.
- Phase Adjustable SMA connectors provide ease of mechanical screw adjustments, compared to the delays and expense of laborious cable-trimming.

Applications

- Base Stations
- Instrumentation
- Process Controls
- Cable Assemblies
- Mil/Aero
- Telecom
- Components
- PC/LAN

Stainless Steel SMA Specifications

Electrical	
Impedance	50 Ω
Frequency Range	.141" & .085" semi-rigid cable: 0-18 GHz Flexible cables: 0-12.4 GHz
Voltage Rating	RG-55, 58, 141, 142, 223, 303: 500 volts peak RG-122, 174, 188, 316: 375 volts peak
Dielectric Withstanding Voltage	.141" & RG-58 Cables: 1,000 VRMS .085" & RG-316 Cables: 750 VRMS
VSWR	Straight connector, .141": 1.05 + .005 f (GHz) Straight connector, .RG-55: 1.15 + .011 f (GHz) Straight connector, RG-122: 1.15 + .02 f (GHz) Straight connector, RG-178: 1.20 + .025 f (GHz) Right angle connector, .141": 1.10 + .01 f (GHz) Right angle connector, .RG-55: 1.15 + .02 f (GHz) Right angle connector, RG-122: 1.15 + .03 f (GHz) Right angle connector, RG-178: 1.20 + .03 f (GHz)
Contact Resistance	Center contact: 2.0 mΩ Body: 2.0 mΩ Braid to body: 0.5 mΩ
Insulation Resistance	5,000 MΩ minimum
Insertion Loss	dB maximum = .03v[f(GHz)]
RF Leakage	-60 dB minimum
Mechanical	
Mating	.250-36 threaded coupling
Mating Torque	Minimum: 2 inch pounds (22 N.cm) Recommended: 7-10 inch pounds (80-110 N.cm) Maximum: 15 inch pounds (170 N.cm)
Coupling Nut Retention	Axial force: 100 inch pounds min. (300 N.cm) Torque: 15 inch pounds. min. (76 N.cm) Jacks: N/A
Connector Affixment to Cable	Crimp and solder types
Cable Affixment to Center Contact	Solder, except as noted
Contact Captivation	All types unless noted otherwise
Cable Retention (Crimp)	RG-58, 303 and .141": 60 lbs. minimum RG-55, 142, & 223: 80 lbs. minimum

Connector Durability	500 mating and unmating cycles @ 12 cycles per minute
Material	
Bodies, Coupling Nuts, Other Metal Parts (except as noted)	Non-magnetic stainless steel style per QQ-S-764, Type 303
Contacts	Beryllium copper per QQ-C-530, heat treated per MIL-H-7199
Center Contact Plating	.00005" minimum gold per MIL-G-45204, type 1, grade C. Gold over nickel unless otherwise requested.
Plating (Other Metal Parts)	Gold plated or passivated to meet the finish and corrosion requirements of MIL-C-39012
Insulator	TFE fluorocarbon per ASTM D1457
Gaskets	Silicone rubber, per MIL-R-5847 and ZZ-R-765 class IIB, grade 65-75.
Lock washers	Stainless steel, internal tooth supplied with all bulkhead mounted connectors
Crimp Ferrule	Seamless copper tubing alloy #122 (DHP), hard drawn to Rockwell 58-77 on 30-T scale per ASTM B75
Environmental	
Temperature Range	- 65°C to +165°C
Thermal Shock	MIL-STD-202 method 107 (test condition B) except high temperatures @ + 200°C
Vibration	MIL-STD-202 method 204 (test condition D)
Shock	MIL-STD-202 method 213 (test condition I). No discontinuity permitted.
Corrosion	MIL-STD-202 method 101 (test condition B) 5% salt solution
Moisture Resistance	MIL-STD-202 method 106, except step 7b (vibration) omitted, and high humidity measurements do not apply
Weatherproofing	Crimp type: heat shrink tubing Solder type: silicone rubber gaskets
Altitude	MIL-STD-202 method 105 (test condition C), no corona at 70,000 feet. .141" & RG-55: 250 VRMS .085" & RG-122: 190 VRMS
Military Specifications	
MIL-C-39012 & MIL-C-83517 SMA Specification Sheets	As applicable

Note: These characteristics are typical but may not apply to all connectors.

Brass SMA Specifications

Electrical	
Impedance	50 Ω
Frequency Range	.141" & .085" semi-rigid cable: 0-18 GHz Flexible cables: 0-12.4 GHz
Voltage Rating	RG-58, 141, 142: 500 volts peak RG-174, 188, 316: 375 volts peak
Dielectric Withstanding Voltage	.141" & RG-58 Cables: 1,000 VRMS .085" & RG-316 Cables: 750 VRMS
VSWR	Straight connector, .141": 1.05 + .005 f (GHz) Straight connector, .RG-174: 1.15 + .02 f (GHz) Straight connector, RG-58: 1.15 + .01 f (GHz) Straight connector, RG-178: 1.20 + .025 f (GHz)
Contact Resistance	Center contact: 2.0 mΩ Body: 2.0 mΩ Braid to body: 0.5 mΩ

Insulation Resistance	5,000 MΩ
Insertion Loss	dB maximum = $.06\sqrt{f[\text{GHz}]}$ Test frequency @ 6.0 GHz
RF Leakage	-90 dB minimum @ 2.3 GHz
Mechanical	
Mating	.250-36 threaded coupling
Mating Torque	Minimum: 2 inch pounds (12 N.cm) Recommended: 7-10 inch pounds (80-110 N.cm) Maximum: 15 inch pounds (170 N.cm)
Connector Durability	100 matings
Material	
Bodies, Coupling Nuts, Other Metal Parts (except as noted)	Brass per QQ-B-626
Contacts	Male: Brass Female: Beryllium copper, heat treated
Center Contact Plating	.000030" minimum gold
Plating (Other Metal Parts)	Standard .000010" gold or nickel plated
Insulator	TFE fluorocarbon
Gaskets	Silicone rubber
Crimp Ferrule	Seamless copper tubing alloy
Environmental	
Temperature Range	- 65°C to +165°C
Thermal Shock	MIL-STD-202 method 107 (test condition B) except high temperatures @ + 200°C
Vibration	MIL-STD-202 method 204 (test condition D)
Shock	MIL-STD-202 method 213 (test condition I). No discontinuity permitted.
Corrosion	MIL-STD-202 method 101 (test condition B) 5% salt solution
Moisture Resistance	MIL-STD-202 method 106, except step 7b (vibration) omitted, and high humidity measurements do not apply
Weatherproofing	Crimp type: heat shrink tubing Solder type: silicone rubber gaskets
Altitude	MIL-STD-202 method 105 (test condition C), no corona at 70,000 feet. .141" & RG-55: 250 VRMS .085" & RG-122: 190 VRMS
Military Specifications	
MIL-C-39012 & MIL-C-83517 SMA Specification Sheets	As applicable

Note: These characteristics are typical but may not apply to all connectors.

Phase Adjustable SMA Specifications

Electrical	
Impedance	50 Ω
Frequency Range	DC-18 GHz
Insertion Loss	dB maximum For adapter 901-508 = $.1\sqrt{f[\text{GHz}]}$ For plug 901-509 = $.08\sqrt{f[\text{GHz}]}$
VSWR	See chart below. ****
Phase Angle Adjustment Range in Degrees	For adapter 901-508 and plug 901-509 = 0° to $[10 \times f[\text{GHz}]]^\circ$ maximum
Phase Angle Change per Revolution of Adjustment Nut in Degrees	For adapter 901-508 and plug 901-509 = $[0.636 \times f[\text{GHz}]]^\circ$
Voltage Rating	500 VRMS peak

Mechanical	
Mating	Mating face dimensions compatible with the mating requirements of MIL-C-39012/55 (Type SMA)
Connector Durability	500 cycles of mating and unmating without deterioration
Material	
Center Contact	Beryllium copper, Gold plated
Connector Body	Brass or Beryllium Copper, Gold plated
Adjusting Nuts and Locking Nuts	Brass with ASTRO plate finish
Connector Coupling Nut	Stainless steel, passivated
Insulation	TFE
Environmental	
Shock	MIL-STD-202 method 213 (test condition I)
Vibration	MIL-STD-202 method 204 (test condition D)
Corrosion	MIL-STD-202 method 101 (test condition B)
Temperature Range	- 65°C to +165°C
Military Specifications	
MIL-C-39012 & MIL-C-83517 SMA Specification Sheets	As applicable

Note: These characteristics are typical but may not apply to all connectors.

Reverse Polarity SMA Specifications

Electrical	
Impedance	50 Ω
Frequency Range	Semi rigid 0 - 18 GHz
Voltage Rating	375 volts peak
Dielectric Withstanding Voltage	1,000 volts rms
VSWR	Straight connectors on .141" S/R: 1.05 + .005 f (GHz) Straight connectors on RG-174: 1.20 + .025 f (GHz)
Insertion Loss	.03 v[f (GHz)] dB maximum
Insulation Resistance	5,000 M Ω
RF Leakage	-60 dB minimum
Mechanical	
Mating	.250-36 threaded coupling
Cable Affixment	Crimp or solder types
Center Conductor	Solder
Cable Retention	60 - 80 lbs depending on cable
Material	
Center Contact	Beryllium copper, gold-plated
Crimp Ferrule	Copper tubing
Other Metal Parts	Non-magnetic passivated stainless steel or brass, gold or silver-plated
Insulators	TFE
Gaskets	Silicone rubber
Environmental	
Temperature Range	-65°C to +165°C
Moisture Resistance	MIL-STD-202, method 106, test condition B
Corrosion	MIL-STD-202, method 101, test condition B
Vibration	MIL-STD-202, method 204, test condition B

Note: These characteristics are typical but may not apply to all connectors.