

REV.	DATE	DESCRIPTION
B	03/27/05	UPDATE DRAWING FORMAT
C	03/08/08	REVISE PLATING TO GOLD, ADD CONTACT PIN IN MATERIAL CALLOUT

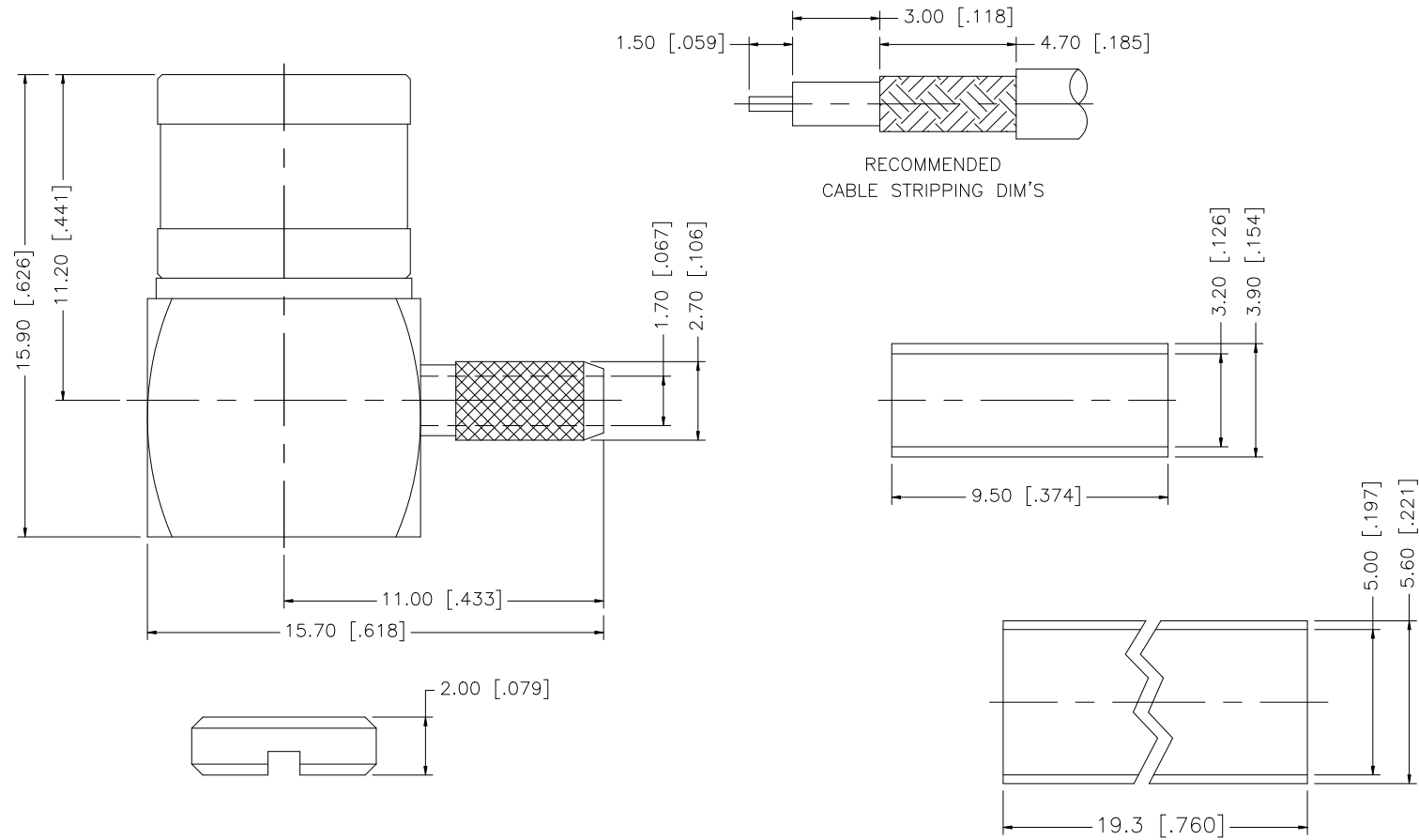

DESCRIPTION	MATERIAL	FINISH	QTY	
8				
7				
6	HEAT SHRINK TUBE		1	
5	FERRULE	BRASS	GOLD	1
4	NUT	BRASS	GOLD	1
3	CONTACT PIN	BRASS	GOLD	1
2	INSULATOR	TEFLON	NATURAL	1
1	BODY	BRASS	GOLD	1

UNLESS OTHERWISE SPECIFIED DIMENSIONS ARE IN MILLIMETERS. DIMENSIONS IN [ ] ARE IN INCHES AND FOR CUSTOMER REFERENCE ONLY.

UNLESS OTHERWISE SPECIFIED TOLERANCES FOR MILLIMETERS ARE:  
 0.5 - 8mm ± 0.20mm  
 8 - 30mm ± 0.40mm  
 30 - 120mm ± 0.50mm

UNLESS OTHERWISE SPECIFIED TOLERANCES FOR INCHES ARE:  
 .020 - .315 = ± 0.007"  
 .315 - 1.180 = ± 0.015"  
 1.180 - 4.724 = ± 0.020"

DO NOT SCALE DRAWING

APPROVALS	DATE
DRAWN G.R.S.	03/08/08
CHECKED	
ISSUED	
SHEET 1 OF 1	
CAD FILE	C:/142/142115.DWG

<h1>Amphenol Connex</h1>			
PART DESCRIPTION SMB R/A CRIMP PLUG (FOR RG-179/U, 184/U CABLE - 75ohm)			
PART NO. 142115			
DWG. NO.	142115.DWG	REV.	C
SIZE	A	SCALE	NA