

REV.	DATE	DESCRIPTION
NC	06/08/98	INITIAL RELEASE
A	06/25/06	UPDATE DRAWING FORMAT, REVISE PLATING TO NEXCOTE

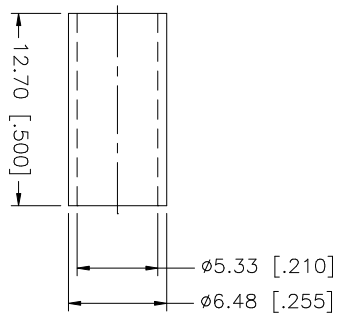
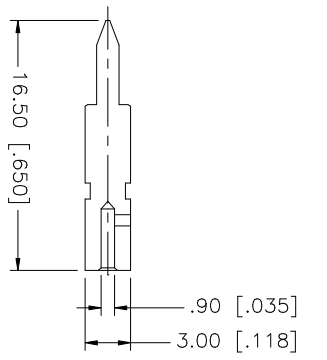
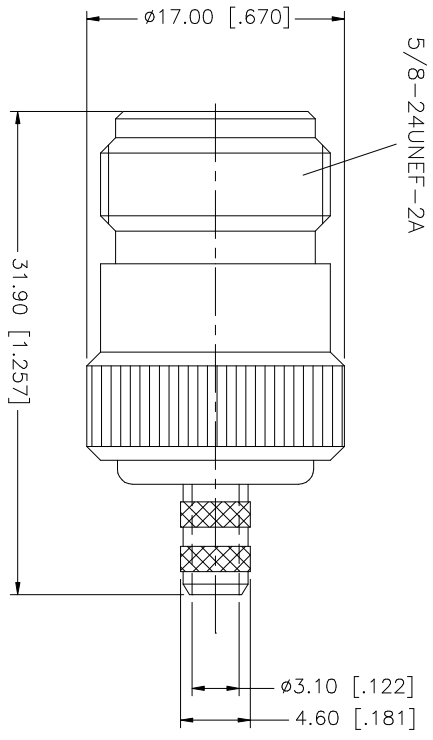
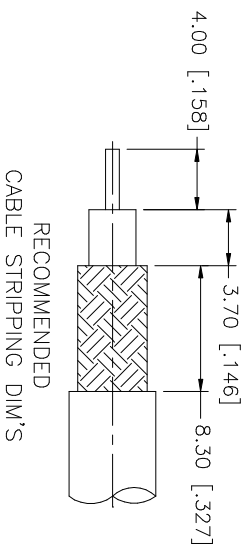

- NOTE:
1. CRIMPED FERRULE HEX. CRIMP SIZE .213"
 2. CRIMPED CONTACT PIN HEX. CRIMP SIZE .105"

QTY	FINISH	MATERIAL	DESCRIPTION
1	NEXCOTE	COPPER	FERRULE
1	GOLD	BRASS	CONTACT PIN
1	NATURAL	TEFLON	INSULATOR
1	NEXCOTE	BRASS	BODY
			DESCRIPTION

UNLESS OTHERWISE SPECIFIED DIMENSIONS ARE IN MILLIMETERS DIMENSIONS IN [] ARE IN INCHES AND FOR SUBSTITUTED REFERENCE ONLY.	
TOLERANCES FOR MILLIMETERS ARE:	
0.5 - 8mm ± 0.20mm	
8 - 30mm ± 0.40mm	
30 - 120mm ± 0.50mm	
UNLESS OTHERWISE SPECIFIED TOLERANCES FOR INCHES ARE:	
.020 - .315 = ± 0.007"	
.315 - 1.180 = ± 0.015"	
1.180 - 4.724 = ± 0.020"	
DO NOT SCALE DRAWING	

APPROVALS	DATE
DRAWN G.R.S.	06/25/06
CHECKED	
ISSUED	
SHEET 1 OF 1	

CAD FILE C:/172/172103RP.DWG	DWG. NO. 172103RP.DWG	REV. A	SIZE A	SCALE NA
---------------------------------	--------------------------	-----------	-----------	-------------

Amphenol Connex

N REVERSE POLARITY CRIMP JACK
(FOR RG-58/U CABLE)

172103RP